

AMD **AMD SP5100** **Register Reference Guide**

Technical Reference Manual
Rev. 3.03

P/N: 44413_sp5100_rrg_pub_3.03

Trademarks

AMD, the AMD Arrow logo and combinations thereof are trademarks of Advanced Micro Devices, Inc.

HyperTransport is a licensed trademark of the HyperTransport Technology Consortium.

Microsoft and Windows are registered trademarks of Microsoft Corporation.

PCI Express and PCIe are registered trademarks of PCI-SIG.

Other product names used in this publication are for identification purposes only and may be trademarks of their respective companies.

Disclaimer

The contents of this document are provided in connection with Advanced Micro Devices, Inc. ("AMD") products. AMD makes no representations or warranties with respect to the accuracy or completeness of the contents of this publication and reserves the right to make changes to specifications and product descriptions at any time without notice. No license, whether express, implied, arising by estoppel, or otherwise, to any intellectual property rights are granted by this publication. Except as set forth in AMD's Standard Terms and Conditions of Sale, AMD assumes no liability whatsoever, and disclaims any express or implied warranty, relating to its products including, but not limited to, the implied warranty of merchantability, fitness for a particular purpose, or infringement of any intellectual property right.

AMD's products are not designed, intended, authorized or warranted for use as components in systems intended for surgical implant into the body, or in other applications intended to support or sustain life, or in any other application in which the failure of AMD's product could create a situation where personal injury, death, or severe property or environmental damage may occur. AMD reserves the right to discontinue or make changes to its products at any time without notice.

Table of Contents

1	Introduction	6
1.1	About this Manual.....	6
1.2	Nomenclature and Conventions.....	6
1.2.1	Recent Updates	6
1.2.2	Numeric Representations.....	6
1.2.3	Register Description.....	6
1.3	Block Diagram	8
2	Register Descriptions: PCI Devices.....	9
2.1	SATA Registers (Bus 0, Device 17, Function 0)	10
2.1.1	PCI Configuration Registers.....	10
2.1.2	SATA I/O Register for IDE Mode.....	40
2.1.2.1	BAR0/BAR2/BAR1/BAR3 Registers	40
2.1.2.2	BAR4 Registers	40
2.1.3	SATA Memory Mapped Register for AHCI Mode	41
2.1.3.1	BAR5 Registers	41
2.1.3.2	Generic Host Control.....	42
2.1.3.3	Offset 00h: CAP – HBA Capabilities.....	42
2.1.3.4	Offset 04h: GHC – Global HBA Control.....	45
2.1.3.5	Offset 08h: IS – Interrupt Status Register.....	46
2.1.3.6	Offset 0Ch: PI – Ports Implemented.....	46
2.1.3.7	Offset 10h: VS – AHCI Version	47
2.1.3.8	Offset 14h: CCC_CTL – Command Completion Coalescing Control.....	47
2.1.3.9	Offset 18h: CCC_PORTS – Command Completion Coalescing Ports	48
2.1.3.10	Port Registers (one set per port)	48
2.1.3.11	Mem_reg: ABAR + port offset + 40h: Reserved for FIS-Based Switching	60
2.2	OHCI USB 1.1 and EHCI USB 2.0 Controllers (Bus 0, Device 18/19/20)	61
2.2.1	OHCI Registers (Device 18/19/20).....	61
2.2.1.1	USB 1 & USB 2 (Device-18/19 function 0) OHCI0 – PCI Configuration Registers.....	61
2.2.1.2	USB1 & USB2 (Device-18/19 function 1) OHCI 1 – PCI Configuration Registers.....	62
2.2.2	USB3 (device-20, fun-5) OHCI PCI Configuration Registers	69
2.2.2.1	USB3 OHCI – PCI Configuration Registers	69
2.2.3	USB1, USB2 & USB3 (Device-18, 19 & Device-20 fun-5) OHCI Memory Mapped Registers.....	74
2.2.4	USB1/ USB2 EHCI PCI Configuration Registers.....	93
2.2.5	EHCI Memory Mapped Register	102
2.2.5.1	EHCI Capability Register.....	102
2.2.5.2	EHCI Operational Register	106
2.2.5.3	USB2.0 Debug Port Register.....	118
2.3	SMBus Module and ACPI Block (Device 20, Function 0)	120
2.3.1	PCI Configuration Registers and Extended Registers.....	121
2.3.1.1	PCI Configuration Registers.....	121
2.3.1.2	Extended Registers.....	147
2.3.2	SMBus Registers	149
2.3.3	Legacy ISA and ACPI Controller	152
2.3.3.1	Legacy Block Registers.....	152
2.3.3.1.1	IO-Mapped Control Registers.....	152
2.3.3.1.2	Client Management Registers (Accessed through C50h and C51h)	164
2.3.3.1.3	System Reset Register (IO CF9).....	166

2.3.3.2	Power Management (PM) Registers.....	166
2.3.3.3	ACPI Registers	216
2.3.3.4	Power Management (PM2) Block2 Registers	220
2.3.4	WatchDogTimer Registers	226
2.3.5	ASF SMBus Host Interface Registers	226
2.3.6	RTC Extended Registers	232
2.4	IDE Controller (Device 20, Function 1)	235
2.4.1	PCI Configuration Registers.....	235
2.4.2	IDE I/O Registers	246
2.5	HD Audio Controller Registers	248
2.5.1	HD Audio Controller PCI Configuration Space Registers (Device 20 Function 2).....	248
2.5.2	HD Audio Controller Memory Mapped Registers	255
3	Register Descriptions: PCI Bridges.....	272
3.1	LPC ISA Bridge (Device 20, Function 3).....	272
3.1.1	Programming Interface.....	272
3.1.2	PCI Configuration Registers.....	272
3.1.3	SPI ROM Controller Registers	290
3.1.4	Features of the LPC Block	293
3.2	Host PCI Bridge Registers (Device 20, Function 4).....	294
3.3	Real Time Clock (RTC)	307
3.4	IOXAPIC Registers.....	314
3.4.1	Direct Access Registers	314
3.4.2	Indirect Access Registers.....	315
Appendix A:	Revision History	317

List of Tables

Table 1-1: Register Description Table Notation—Example.....	6
Table 2-1 Legacy Support Registers.....	90
Table 2-2 Emulated Registers.....	90
Table 2-3: IO Drive Strength Recommendations for Various Interfaces	144
Table 2-4: IO Drive Strength Recommendations for the IDE Interface	144
Table 3-1 PCI-to-PCI Bridge Configuration Registers Summary.....	294

1 Introduction

1.1 About this Manual

This manual is a register reference guide for the AMD SP5100 (previously referred to by its code name “SB700S” in this guide).

AMD’s SP5100 southbridge integrates the key I/O, communications, and audio features required in a state-of-the-art PC into a single device.

1.2 Nomenclature and Conventions

1.2.1 Recent Updates

Updates recent to each revision are highlighted in red.

1.2.2 Numeric Representations

- Hexadecimal numbers are prefixed with “0x” or suffixed with “h,” whenever there is a possibility of confusion. Other numbers are decimal.
- Registers (or fields) of an identical function are sometimes indicated by a single expression in which the part of the signal name that changes is enclosed in square brackets. For example, registers HOST_DATA0 through to HOST_DATA7 is represented by the single expression HOST_DATA[7:0].

1.2.3 Register Description

All registers in this document are described with the format of the sample table below. All offsets are in hexadecimal notation, while programmed bits are in either binomial or hexadecimal notation.

Table 1-1: Register Description Table Notation—Example

Latency Timer – RW – 8 bits – [Offset: 0Dh]			
Field Name	Bits	Default	Description
Latency Timer (R/W)	7:0	00h	This bit field is used to specify the time in number of PCI clocks, the SATA controller as a master is still allowed to control the PCI bus after its GRANT_L is deasserted. The lower three bits [0A:08] are hardwired to 0 h , resulting in a time granularity of 8 clocks.
Latency Timer. Reset Value: 00h			

Register Information	Value/Content in the Example
Register name	Latency Timer
Read / Write capability R = Readable W = Writable RW = Readable and Writable	RW
Register size	8 bits
Register address(es)*	Offset: 0Dh
Field name	Latency Timer (R/W)
Field position/size	7:0
Field default value	00h
Field description	"This bit ... 8 clocks."
Field mirror information	
Brief register description	Latency Timer. Reset Value: 00h
<p>* Note: There maybe more than one address; the convention used is as follows:</p> <p>[aperName:offset] - single mapping, to one aperture/decode and one offset [aperName1, aperName2, ..., aperNameN:offset] - multiple mappings to different apertures/decodes but same offset [aperName:startOffset-endOffset] - mapped to an offset range in the same aperture/decode</p>	

Warning: Do not attempt to modify values of registers or bit fields marked "Reserved." Doing so may cause the system to behave in unexpected manners.

1.3 Block Diagram

This section contains a diagram for the SP5100. *Figure 1* below shows the SP5100 internal PCI devices and the major function blocks.

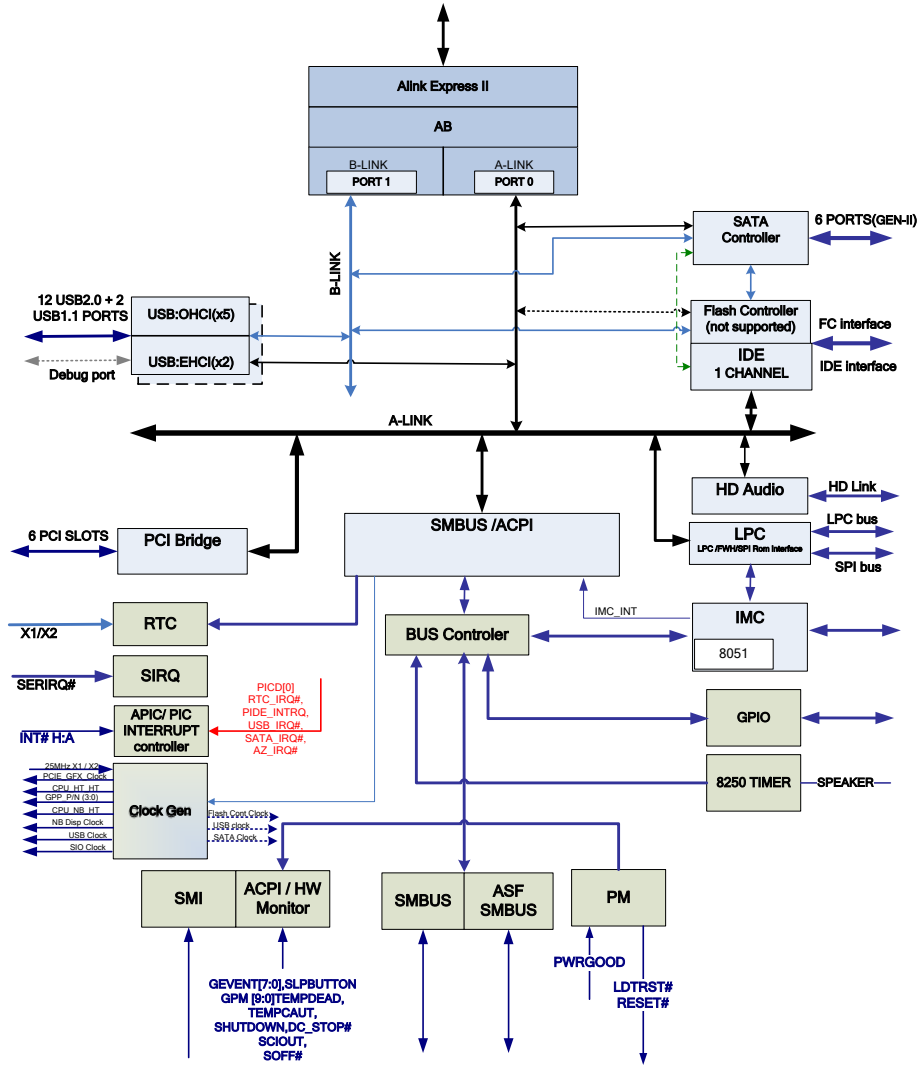

Figure 1 SP5100 PCI Internal Devices and Major Function Blocks

2 Register Descriptions: PCI Devices

Note: The SP5100 internal PCI devices are listed in [Figure 2](#) below. The sub-sections that follow provide descriptions of the PCI configuration space, the I/O space, and the memory space registers for each device. PCI configuration space registers are only accessible with configuration read or configuration write cycles and with the target device selected by settling its corresponding IDSEL bit in the configuration cycle address field.

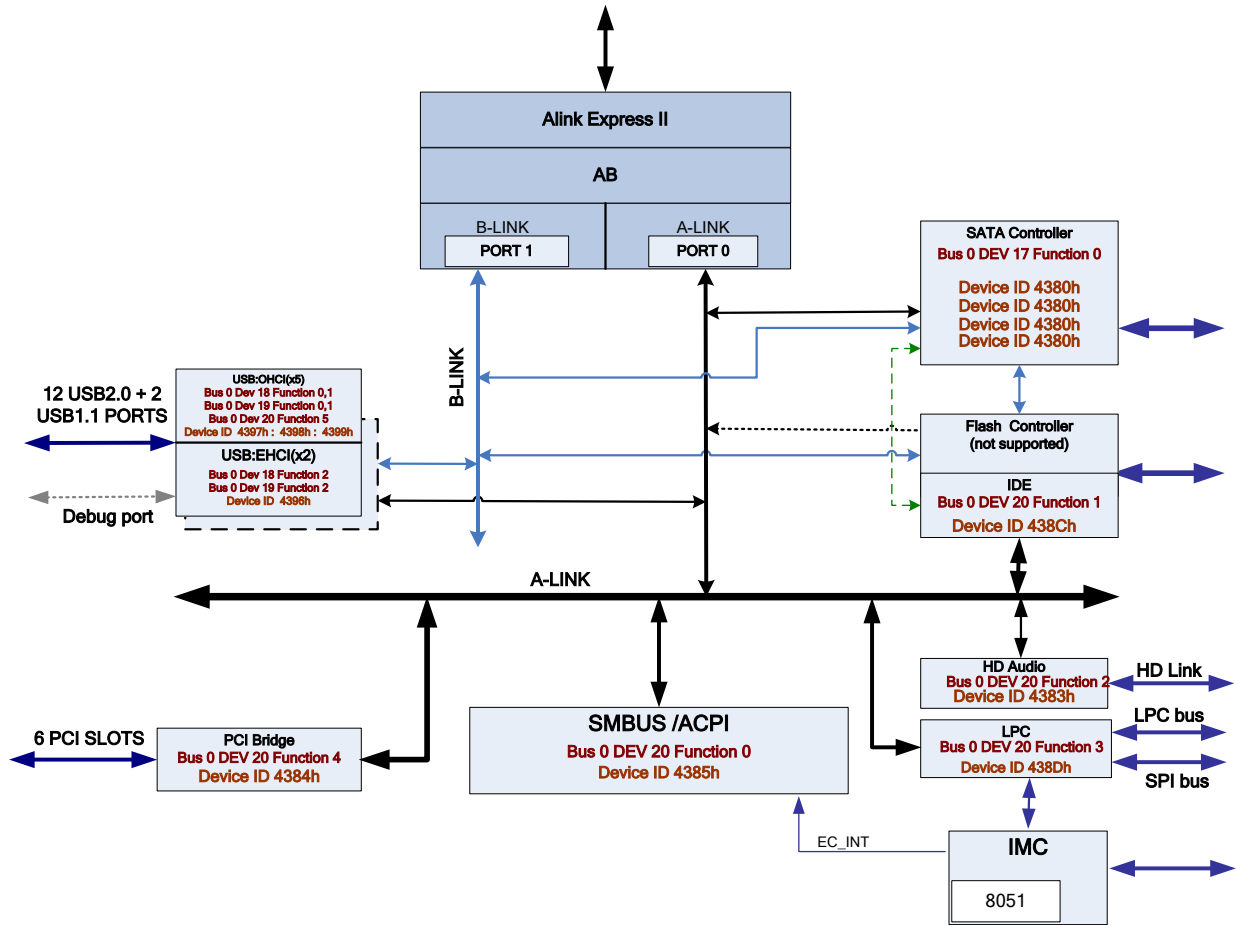
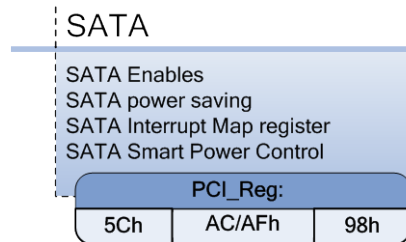

Figure 2: SP5100 PCI Internal Devices

2.1 SATA Registers (Bus 0, Device 17, Function 0)

SATA registers are composed of PCI Config, Memory mapped I/O and I/O space registers. These registers are cleared by the PCIRST# signal; therefore, they will be cleared on a warm boot.

Note: Some SATA functions are controlled by, and associated with, certain PCI configuration registers in the SMBus/ACPI device. For more information refer to [section 2.4: SMBus Module and ACPI Block \(Device 20, Function 0\)](#). The diagram below lists these SATA functions and the associated registers.



2.1.1 PCI Configuration Registers

These registers are accessible only when the SATA controller detects a Configuration Read or Write operation, with its IDSEL asserted, on the 32-bit PCI bus.

Register Name	Offset Address
Vendor ID	00h
Device ID	02h
Command	04h
Status	06h
Revision ID/Class Code	08h
Cache Link Size	0Ch
Master Latency Timer	0Dh
Header Type	0Eh
BIST Mode Type	0Fh
Base Address 0	10h
Base Address 1	14h
Base Address 2	18h
Base Address 3	1Ch
Bus Master Interface Base Address	20h
AHCI Base Address	24h
Subsystem ID and Subsystem Vendor ID	2Ch
Capabilities Pointer	34h
Interrupt Line	3Ch
Interrupt Pin	3Dh
Min_gnt	3Eh
Max_latency	3Fh
Misc control	40h
Watch Dog Control And Status	44h
Watch Dog Counter	46h
Blink Control	48h
MSI Control	50h
MSI Address	54h
MSI Upper Address	58h
MSI Data	5Ch
Power Management Capability ID	60h
Power Management Capability	62h
Power Management Control And Status	64h
Serial ATA Capability Register 0	70h
Serial ATA Capability Register 1	74h

Register Name	Offset Address
IDP Index	78h
IDP Data	7Ch
PHY Test In	80h
PHY Test Out	82h
PHY Mode	84h
PHY Global Control	86h
PHY Port0 Control	88h
PHY Port1 Control	8Ch
PHY Port2 Control	90h
PHY Port3 Control	94h
PHY Port4 Control	98h
PHY Port5 Control	9Ch
PHY Port0 GENII Control	A0h
PHY Port1 GENII Control	A2h
PHY Port2 GENII Control	A4h
PHY Port3 GENII Control	A6h
PHY Port4 GENII Control	A8h
PHY Port5 GENII Control	AAh
Port0 BIST Error Count	ACh
Port0 BIST Control/Status	B0h
Reserved	B2h
Port1 BIST Error Count	B4h
Port1 BIST Control/Status	B8h
Reserved	BAh
Port2 BIST Error Count	BCh
Port2 BIST Control/Status	C0h
Reserved	C2h
Port3 BIST Error Count	C4h
Port3 BIST Control/Status	C8h
Reserved	CAh
Port4 BIST Error Count	CCh
Port4 BIST Control/Status	D0h
Reserved	D2h
Port5 BIST Error Count	D4h
Port5 BIST Control/Status	D8h
Reserved	DAh
BIST pattern Count	DCh
PCI Target Control TimeOut Counter	E0h
T-Mode BIST Transit Pattern DW1	E4h
T-Mode BIST Transit Pattern DW2	E8h
BIST Transmit Pattern Definition	ECh
Reserved	EE-EFh
20-BIT BIST Transmit Pattern	F0
Reserved	F3h-FFh

Vendor ID - R - 16 bits - [PCI_Reg:00h]			
Field Name	Bits	Default	Description
Vendor ID	15:0	1002h	This register holds a unique 16-bit value assigned to a vendor. And combined with the device ID, it identifies any PCI device.

Device ID - R - 16 bits - [PCI_Reg:02h]			
Field Name	Bits	Default	Description
Device ID	15:0	4390h	<p>This register holds a unique 16-bit value assigned to a device. When used with the combination of base class and sub-class, the correct functionality of the SATA mode will be enabled by hardware and software.</p> <p>Note: To make Device ID 4394h, software will program an unlock bit (PCI_CFG 0x40[24]) to 1'b1. Once programmed, Device ID becomes read-only. This bit supersedes the bonding option and the writing of the Device ID field. That is to say, in order to make Device ID 4390h or 4391h, PCI_CFG 0x40[24] must be programmed to 1'b0 (default).</p>

Note: The SP5100 SATA controller supports multiple Device IDs to accommodate different SATA configurations. The following configurations are supported through BIOS programming:

- IDE (IDE emulation mode)
- AHCI mode
- RAID 0 / RAID 1 and RAID 10

The SP5100 Device IDs and sub-class codes are assigned as follows:

Mode	Device ID	Sub-Class Code	PCI_CFG 0x40[24]
IDE	4390h	01h	0
AHCI ¹	4391h	06h	0
RAID 0, 1, 10 ³	4392h	04h	0
AHCI ²	4394h	06h	1

Note 1: For Microsoft® inbox AHCI driver support
Note 2: For AMD inbox AHCI driver support (Recommended)
Note 3: RAID driver support (from third party. AMD does not provide RAID driver)

Command - RW - 16 bits - [PCI_Reg:04h]			
Field Name	Bits	Default	Description
I/O Access Enable	0	0b	This bit controls access to the I/O space registers. When this bit is 1, it enables SATA controller to response to PCI IO space access.
Memory Access Enable	1	0b	This bit controls access to the memory space registers. When this bit is 1, it enables SATA controller to response to PCI memory space access
Bus Master Enable	2	0b	Bus master function enable. 1: Enable 0: Disable.
Special Cycle Recognition Enable	3	0b	Read Only. Hard-wired to '0' indicates that there is no special support.
Memory Write and Invalidate Enable	4	0b	Read Only. Hard-wired to '0' indicates that memory write and invalidate command is not supported.
VGA Palette Snoop Enable	5	0b	Read Only. Hard-wired to '0' indicates the SATA host controller does not need to snoop VGA palette cycles.
PERR- Detection Enable	6	0b	If set to 1, the IDE host controller asserts PERR- when it is the agent receiving data AND it detects a parity error. PERR- is not asserted if this bit is 0.
Wait Cycle Enable	7	0b	Read Only. Hard-wired to '0' indicates the SATA controller does not need to insert a wait state between the address and data on the AD lines.

Command - RW - 16 bits - [PCI_Reg:04h]			
Field Name	Bits	Default	Description
SERR- Enable	8	0b	If set to 1 and bit 6 is set, the SATA controller asserts SERR- when it detects an address parity error. SERR- is not asserted if this bit is 0.
Fast Back-to-Back Enable	9	0b	Read Only. Hard-wired to '0' indicates that fast back to back to the same agent are allowed only.
Interrupt Disable	10	0b	(Complies to PCI 2.3 spec.)
Reserved	15:11	00h	Reserved.
Reset Condition: PCI Reset, or Power Management State transition from D3 to D0.			

Status - RW - 16 bits - [PCI_Reg:06h]			
Field Name	Bits	Default	Description
Reserved	2:0	0h	Reserved.
Interrupt Status	3	0b	Interrupt status bit. It complies with the PCI 2.3 specification.
Capabilities List	4	1b	Read Only. Default to 1 to indicate that the Capabilities Pointer is located at 34h.
66MHz Support	5	1b	66MHz capable. This feature is supported in the SATA controller.
Reserved	6	0b	Reserved.
Fast Back-to-Back Capable	7	0b	Read Only. Hard-wired to '0' indicates that Fast Back-to-Back incapable.
Data Parity Error	8	0b	Data Parity reported. Set to 1 if the SATA controller detects PERR- asserted while acting as PCI master (whether PERR- was driven by SATA controller or not.) Write '1' clears this bit.
DEVSEL- Timing	10:9	01b	Read only. These bits indicate DEVSEL- timing when performing a positive decode. Since DEVSEL- is asserted to meet the medium timing, these bits are encoded as 01b.
Signaled Target Abort	11	0b	Signaled Target Abort. This bit is set to 1, when the SATA controller signals Target Abort. Write '1' clears this bit.
Received Target Abort	12	0b	Received Target Abort. This bit is set to 1 when the SATA controller generated PCI cycle (SATA controller is the PCI master) is aborted by a PCI target. Cleared by writing a 1 to it.
Received Master Abort Status	13	0b	Received Master Abort Status. Set to 1 when the SATA controller acting as a PCI master, aborts a PCI bus memory cycle. Cleared by writing a 1 to this bit. Write '1' clears this bit.
SERR- Status	14	0b	SERR- status. This bit is set to 1 when the SATA controller detects a PCI address parity error. Write '1' clears this bit.
Detected Parity Error	15	0b	Detected Parity Error. This bit is set to 1 when the SATA controller detects a parity error. Write '1' clears this bit.
Bit [15:8] are read/write. However, writes "1" will clear these bits.			
Reset Condition: PCI Reset, or Power Management State transition from D3 to D0.			

Revision ID/Class Code- R - 32 bits - [PCI_Reg:08h]			
Field Name	Bits	Default	Description
Revision ID	7:0	00h	These bits are default to 00h to indicate the revision level of the chip design.

Revision ID/Class Code- R - 32 bits - [PCI_Reg:08h]															
Field Name	Bits	Default	Description												
Operating Mode Selection	15:8	8Fh	RW Programmable I/F. Bit [15]: Master IDE Device. Always 1. Bits [14:12]: Reserved. Always read as 0's. Bit [11]: Programmable indicator for Secondary. Always 1 to indicate that both modes are supported. Bit [10]: Operating Mode for Secondary. 1: Native PCI-mode. 0: Compatibility Mode Bit [9]: Programmable indicator for Primary. Always 1 to indicate that both modes are supported. Bit [8]: Operating Mode for Primary. 1: Native PCI-mode. 0: Compatibility mode See *Note 1												
Sub-Class Code	23:16	01h	Sub-Class Code. 01h to indicate an IDE Controller. See *Note 2.												
Class Code	31:24	01h	Class Code. These 8 bits are read only and wired to 01h to indicate a Mass-Storage Controller.												
<p>*Note 1: Bits [15:8] are writable when PCI_REG 40h[0] is 1. In IDE mode (sub class code ==01) bits [11:8] are writable when PCI_REG 40h[0] ==0.</p> <p>*Note 2: This field is only write-able when PCI_Reg:40h[0] is set.</p> <table border="0"> <tr> <td>Sub-Class Code</td> <td>Program Interface:</td> <td>Controller Type</td> </tr> <tr> <td>01</td> <td>8F</td> <td>IDE</td> </tr> <tr> <td>06</td> <td>01</td> <td>AHCI</td> </tr> <tr> <td>04</td> <td>00</td> <td>RAID</td> </tr> </table> <p>Reset Condition: PCI Reset.</p>				Sub-Class Code	Program Interface:	Controller Type	01	8F	IDE	06	01	AHCI	04	00	RAID
Sub-Class Code	Program Interface:	Controller Type													
01	8F	IDE													
06	01	AHCI													
04	00	RAID													

Cache Line Size - RW - 8 bits - [PCI_Reg:0Ch]			
Field Name	Bits	Default	Description
Reserved	3:0	0h	Reserved
Cache Line Size Register	7:4	0h	If the value is 1, cache line size is 16 DW (64 byte).
Reset Condition: PCI Reset, or Power Management State transition from D3 to D0.			

Master Latency Timer - RW - 8 bits - [PCI_Reg:0Dh]			
Field Name	Bits	Default	Description
Reserved	2:0	0h	Reserved
Master Latency Timer	7:3	00h	Master Latency Timer. This number in units of PCICLKs represents the guaranteed time slice allowed to IDE host controller for burst transactions.
Reset Condition: PCI Reset, or Power Management State transition from D3 to D0.			

Header Type - R - 8 bits - [PCI_Reg:0Eh]			
Field Name	Bits	Default	Description
Header Type	7:0	00h	Header Type. Since the IDE host controller is a single-function device, this register contains a value of 00h. Bit [7] is writable when PCI configuration register 40h[0] is set. This applies to ASIC Revision A12.

BIST Mode Type - RW - 8 bits - [PCI_Reg:0Fh]			
Field Name	Bits	Default	Description
Completion Code	3:0	0h	Read Only. Indicates the completion code status of BIST. A non-zero value indicates a failure.

BIST Mode Type - RW - 8 bits - [PCI_Reg:0Fh]			
Field Name	Bits	Default	Description
Reserved	5:4	0h	Reserved
Start BIST	6	0b	Since bit [7] is 0, programming this bit takes no effect.
BIST Capable	7	0	Read Only. Hard-wired to '0' Indicates no HBA related BIST function
Reset Condition: PCI Reset, or Power Management State transition from D3 to D0. Note: This does not indicate SATA BIST capability			

Base Address 0 - RW - 32 bits - [PCI_Reg:10h]			
Field Name	Bits	Default	Description
Resource Type Indicator	0	1b	RTE (Resource Type Indicator). This bit is wired to 1 to indicate that the base address field in this register maps to I/O space.
Reserved	2:1	0h	Reserved.
Primary IDE CS0 Base Address	31:3	0000_0000h	Base Address for Primary IDE Bus CS0. This register is used for native mode only. Base Address 0 is not used in compatibility mode.
Reset Condition: PCI Reset, or Power Management State transition from D3 to D0.			

Base Address 1 - RW - 32 bits - [PCI_Reg:14h]			
Field Name	Bits	Default	Description
Resource Type Indicator	0	1b	RTE (Resource Type Indicator). This bit is wired to 1 to indicate that the base address field in this register maps to I/O space.
Reserved	1	0b	Reserved.
Primary IDE CS1 Base Address	31:2	0000_0000h	Base Address for Primary IDE Bus CS1. This register is used for native mode only. Base Address 1 is not used in compatibility mode.
Reset Condition: PCI Reset, or Power Management State transition from D3 to D0.			

Base Address 2 - RW - 32 bits - [PCI_Reg:18h]			
Field Name	Bits	Default	Description
Resource Type Indicator	0	1b	RTE (Resource Type Indicator). This bit is wired to 1 to indicate that the base address field in this register maps to I/O space for IDE mode. When flash controller is enabled (PM_Reg_59, bit 1), this bit is '0' to indicate that the base address field in this register maps to memory space.
Reserved	2:1	0h	Reserved.
Secondary IDE CS0 Base Address or Flash Controller base address	31:3 (See Note)	0000_0000h	Under IDE mode, this serves as the base Address for Secondary IDE Bus CS0. This register is used for native mode only. Base Address 2 is not used in compatibility mode. When flash controller is enabled (PM_Reg_59, bit 1), this register serves as the base address for the flash controller Note: When this register serves as the base address for the flash controller, bits [16:3] are read-only.
Reset Condition: PCI Reset, or Power Management State transition from D3 to D0.			

Base Address 3 - RW - 32 bits - [PCI_Reg:1Ch]			
Field Name	Bits	Default	Description
Resource Type Indicator	0	1b	RTE (Resource Type Indicator). This bit is wired to 1 to indicate that the base address field in this register maps to I/O space.
Reserved	1	0b	Reserved.

Base Address 3 - RW - 32 bits - [PCI_Reg:1Ch]			
Field Name	Bits	Default	Description
Secondary IDE CS1 Base Address	31:2	0000_0000h	Base Address for Secondary IDE Bus CS1. This register is used for native mode only. Base Address 3 is not used in compatibility mode.
Reset Condition: PCI Reset, or Power Management State transition from D3 to D0.			

Bus Master Interface Base Address - RW - 32 bits - [PCI_Reg:20h]			
Field Name	Bits	Default	Description
Resource Type Indicator	0	1b	RTE (Resource Type Indicator). This bit is wired to 1 to indicate that the base address field in this register maps to I/O space.
Reserved	3:1	0h	Reserved.
Bus Master Interface Register Base Address	31:4	000_0000h	Base Address for Bus Master interface registers and correspond to AD[15:4].
Reset Condition: PCI Reset, or Power Management State transition from D3 to D0.			

AHCI Base Address - RW - 32 bits - [PCI_Reg:24h]			
Field Name	Bits	Default	Description
Resource Type Indicator	0	0b	RTE (Resource Type Indicator). This bit is wired to 0 to indicate a request for register memory space.
Reserved	9:1	000h	Reserved.
AHCI Base Address	31:10	00_0000h	Base address of register memory space. This represents a memory space for support of 4 ports.
Reset Condition: PCI Reset, or Power Management State transition from D3 to D0.			

Subsystem ID and Subsystem Vendor ID - RW - 32 bits - [PCI_Reg:2Ch]			
Field Name	Bits	Default	Description
Subsystem Vendor ID	15:0	0000h	Subsystem Vendor ID. Can only be written once by software.
Subsystem ID	31:16	0000h	Subsystem ID. Can only be written once by software.
Write once and read only. Reset Condition: PCI Reset.			

Capabilities Pointer - R - 8 bits - [PCI_Reg:34h]			
Field Name	Bits	Default	Description
Capabilities Pointer	7:0	60h	The first pointer of Capability block.

Interrupt Line - RW - 8 bits - [PCI_Reg:3Ch]			
Field Name	Bits	Default	Description
Interrupt Line	7:0	00h	Identifies which input on the interrupt controller the function's PCI interrupt request pin (as specified in its Interrupt Pin register) is routed to
Reset Condition: PCI Reset, or Power Management State transition from D3 to D0.			

Interrupt Pin - R - 8 bits - [PCI_Reg:3Dh]			
Field Name	Bits	Default	Description
Interrupt Pin	7:0	01h	Hardwired to 01h.

Min_gnt - R - 8 bits - [PCI_Reg:3Eh]			
Field Name	Bits	Default	Description
Minimum Grant	7:0	00h	This register specifies the desired settings for how long of a burst the SATA controller needs. The value specifies a period of time in units of ¼ microseconds. Hard-wired to 0's and always read as 0's.

Max_latency - R - 8 bits - [PCI_Reg:3Fh]			
Field Name	Bits	Default	Description
Maximum Latency	7:0	00h	This register specifies the Maximum Latency time required before the SATA controller as a bus-master can start an accesses Hardwired to 0's and always read as 0's.

Misc Control - RW - 32 bits - [PCI_Reg:40h]			
Field Name	Bits	Default	Description
Subclass code write Enable	0	0b	Once set, Program Interface register (PCI_Reg:09h), Subclass code register (PCI_Reg:0Ah), Multiple Message Capable bits (PCI_Reg50h[19:17]) can be programmable.
Disable Dynamic Sata Memory Power Saving	1	0b	When clear, dynamic power saving function for SATA internal memory macros will be performed to reduce power consumption.
Enable dynamic Sata Core Power Saving	2	0b	When set, dynamic power saving function for SATA core clock will be performed during partial/slumber mode to reduce power consumption. See Note 1.
Reserved	3	0b	Reserved
Disable Speed up XP Boot	4	0b	When clear, it fastens XP boot up in IDE mode. However, this bit needs to be set, when enable SATA partial/slumber power function is in IDE mode. When set, the SATA partial/slumber power function can be enabled in IDE mode, but the BIOS IO trap is needed to speed up XP boot-up in IDE mode. Please refer to BAR5 + offset 12C/1Ac/22C/2AC[11:8] for the SATA partial/slumber modes that are allowed.
Enable Dynamic Interface Clock Power Saving	5	0b	When set, dynamic power saving function for SATA internal bus interface clock will be performed while there is no outstanding DMA transaction. See Note 2.
Reserved	15:6	000h	Reserved
Disable port0	16	0b	When set, port0 is disabled and port0 clock is shut down. See Note3.
Disable port1	17	0b	When set, port1 is disabled and port1 clock is shut down.
Disable port2	18	0b	When set, port2 is disabled and port2 clock is shut down.
Disable port3	19	0b	When set, port3 is disabled and port3 clock is shut down.
Disable port4	20	0b	When set, port4 is disabled and port4 clock is shut down.
Disable port5	21	0b	When set, port5 is disabled and port5 clock is shut down.
Reserved	23:22	00b	Reserved
Lock Flash Device ID	24	0b	When set, SATA Device ID will be Read-Only, and has value 0x4394h. When cleared, SATA Device ID will be writable according to the values, other than 0x4394h, defined in PCI_CFG 0x00[31:16].
Reserved	28:25	0h	Reserved
Disabling testing/enhancement mode	29	0b	Disabling testing/enhancement mode in SATA. Need to be programmed to 1 and recovered after S0 power lost.
Reserved	31:30	00b	Reserved

Misc Control - RW - 32 bits - [PCI_Reg:40h]			
Field Name	Bits	Default	Description
Reset Condition: PCI Reset.			
Note1: Bit [2]: To enable dynamic sataclk shut down function. Sataclk will be shut down during partial/slumber mode. It will automatically wake-up when received new commands from software, or received COMWAKE/COMINIT from device. This function will be effective when this bit is set also ACPI-PCI_reg ACh[13]			
Note2: When set, enable dynamic blink clock shut down. Blink clk will be shut down when there is no outstanding DMA operation. "BAR4 + offset 0/8h[0] = 1'b1", or "BAR5 +offset 134/1B4/234/2B4[31:0] = non-zeros" ,or "BAR5 +offset 138/1B8/238/2B8[31:0] = non-zeros" means there is DMA operation on going.			
Note3: When set, put PHY port0 is disabled, shut down port0 clock at link/transport layer.			

Watch Dog Control And Status - RW - 16 bits - [PCI_Reg:44h]			
Field Name	Bits	Default	Description
Watchdog Enable	0	0b	Set the bit to enable the watchdog counter for all the PCI down stream transaction for both SATA and PATA ports.
Watchdog Timeout Status	1	0b	Watchdog Counter Timeout Status bit. This bit indicates that the watchdog counter has expired for PCI down stream transaction and the transaction got aborted due to the fact that the counter has expired. Software writes 1 to clear the status
PATA Watchdog Timeout Status	2	0b	PATA Watchdog Counter Timeout Status bit. This bit indicates that the watchdog counter in a PATA port has expired for PCI down stream transaction and the transaction got aborted due to counter has expired. Software writes 1 to clear the status
Reserved	15:3	0000h	Reserved. Still read/write-able.
This register is used from preventing system hang. Reset Condition: PCI Reset, or Power Management State transition from D3 to D0.			

Watch Dog Counter - RW - 16 bits - [PCI_Reg:46h]			
Field Name	Bits	Default	Description
Watchdog Counter	7:0	80h	Specifies the timeout retry count for PCI down stream retries. This value is used for both SATA and PATA ports.
Reserved	15:8	00h	Reserved. Still read/write-able.
This register is used from preventing system hang. Reset Condition: PCI Reset, or Power Management State transition from D3 to D0.			

B-Link Control - RW - 32 bits - [PCI_Reg:48h]			
Field Name	Bits	Default	Description
Reserved	23:0	00_0000h	Reserved. Still read/write-able.
Disabling testing/enhancement mode	24	0b	Disabling testing/enhancement mode in SATA. Need to be programmed to 1 and recovered after S0 power lost.
Reserved	31:25	00h	Reserved. Still read/write-able.
Reset Condition: PCI Reset, or Power Management State transition from D3 to D0.			

MSI Control - RW- 32 bits - [PCI_Reg:50h]			
Field Name	Bits	Default	Description
Capability ID	7:0	05h	Read-Only. Capability ID. Indicates this is MSI capability ID.
Capability Next Pointer	15:8	70h	Read-Only. Next Pointer (Default to 70h, points to Index Data pair capability).
Message Signaled Interrupt Enable	16	0b	MSI Enable

MSI Control - RW- 32 bits - [PCI_Reg:50h]			
Field Name	Bits	Default	Description
Multiple Message Capable	19:17	010b	Multiple Message Capable (MMC). *Note
Multiple Message Enable	22:20	0h	Multiple Message Enable (MME).
MSI 64-bit Address	23	1b	Read Only 64-bit address supported
Reserved	31:24	00h	Reserved.
Reset Condition: PCI Reset, or Power Management State transition from D3 to D0.			

MSI Address - RW- 32 bits - [PCI_Reg:54h]			
Field Name	Bits	Default	Description
Reserved	1:0	0h	Reserved.
MSI Address	31:2	0000_0000h	Lower 32 bits of the system specified message address always DW aligned.
Reset Condition: PCI Reset, or Power Management State transition from D3 to D0.			

MSI Upper Address - RW- 32 bits - [PCI_Reg:58h]			
Field Name	Bits	Default	Description
MSI Upper Address	31:0	0000_0000h	MSI Upper Address: Upper 32 bits of the system specified message address. This register is optional and only implemented if MC.C64=1.
Reset Condition: PCI Reset, or Power Management State transition from D3 to D0.			

MSI Data - RW- 16 bits - [PCI_Reg:5Ch]			
Field Name	Bits	Default	Description
MSI Data	15:0	0000h	MSI Data
Reset Condition: PCI Reset, or Power Management State transition from D3 to D0.			

Power Management Capability ID – R - 16 bits - [PCI_Reg:60h]			
Field Name	Bits	Default	Description
Capability ID	7:0	01h	Capability ID (Default to 01h, indicates that this pointer is a PCI power management).
Capability Next Pointer	15:8	50h	Next Pointer (hard wired to 50h, points to MSI capability).
Reset Condition: PCI Reset, or Power Management State transition from D3 to D0.			

Power Management Capability - R- 16 bits - [PCI_Reg:62h]			
Field Name	Bits	Default	Description
Version (VS)	2:0	010b	Indicates support for Revision 1.1 of the <i>PCI Power Management Specification</i> .
PME Clock (PMEC)	3	0b	Indicates that PCI clock is not required to generate PME#.
Reserved	4	0b	Reserved
Device Specific Initialization	5	1b	Indicates whether device-specific initialization is required. Hard wire to 1.
Aux_Current	8:6	0h	Reports the maximum Suspend well current required when in the D3 _{COLD} state. Hard wire to 000b.
D1_Support	9	0b	The D1 state is not supported.
D2_Support	10	0b	The D2 state is not supported.
PME_Support	15:11	00h	Hard wired to 00h.

PCI Power Management Control And Status - RW- 16 bits - [PCI_Reg:64h]			
Field Name	Bits	Default	Description
Power State (PS)	1:0	00b	This field is used both to determine the current power state of the HBA and to set a new power state. The values are: 00 – D0 state 11 – D3 _{HOT} state The D1 and D2 states are not supported. When in the D3 _{HOT} state, the configuration space is available, but the register memory spaces are not. Additionally, interrupts are blocked.
Reserved	7:2	00h	Reserved
PME Enable (PMEE)	8	0b	Read Only. Hard-wired to '0' indicates PME disable
Reserved	14:9	00h	Reserved.
PME Status	15	0b	Read Only. Hard-wired to '0' as PME disable
Reset Condition: PCI Reset.			

Serial ATA Capability Register 0 - R- 32 bits - [PCI_Reg:70h]			
Field Name	Bits	Default	Description
Capability ID	7:0	12h	Capability ID (hard wired to 12h, indicates that this pointer is a Serial ATA Capability)
Capability Next Pointer	15:8	00h	Next Pointer. end of list.
Minor Revision	19:16	0h	Minor revision number of the SATA Capability Pointer implemented.
Major Revision	23:20	1h	Major revision number of the SATA Capability Pointer implemented.
Reserved	31:24	00h	Reserved
This set of registers when supported is used for the Index-Data Pair mechanism.			

Serial ATA Capability Register 1 - R- 32 bits - [PCI_Reg:74h]			
Field Name	Bits	Default	Description
BAR Location	3:0	1111b	Value 1111b Indicates Index-Data pair is implemented in Dwords directly following SATACR1 in the PCI configuration space.
BAR Offset	23:4	000h	Indicates the offset into the BAR where the Index-Data Pair are located in Dword granularity.
Reserved	31:24	00h	Reserved.
This set of registers when supported is used for the Index-Data Pair mechanism.			

IDP Index Register - RW- 32 bits - [PCI_Reg:78h]			
Field Name	Bits	Default	Description
Reserved	1:0	0h	Reserved.
IDP Index	9:2	00h	This register selects the Dword offset of the memory mapped AHCI register to be accessed. The IDP Index should be sized such that it can access the entire ABAR register space for the particular implementation.
Reserved	31:10	00_0000 h	Reserved
This set of registers, when supported, is used for the Index-Data Pair mechanism. Reset Condition: PCI Reset, or Power Management State transition from D3 to D0.			

IDP Data Register - RW- 32 bits - [PCI_Reg:7Ch]			
Field Name	Bits	Default	Description
IDP Data	31:0	F722_FF 85h	This register is a “window” through which data is read or written to the memory mapped register pointed to by the IDP Index register. Note that a physical register is not actually implemented as the data is actually stored in the memory mapped registers. Since this is not a physical register, the “default” value is the same as the default value of the register pointed to by IDP Index.
All register accesses to IDP Data are Dword granularity.			

PHY Test In - RW- 16 bits - [PCI_Reg:80h]			
Field Name	Bits	Default	Description
PHY transmission enable	0	0b	SATA PHY transmisión enable (txen)
PHY transmission clock	1	0b	SATA PHY transmisión clock (tbc)
PHY Test Input data	11:2	000h	SATA PHY transmisión data (txd0:9)
Reserved	15:12	0h	Reserved. Still read/write-able.
Reset Condition: PCI Reset, or Power Management State transition from D3 to D0.			

PHY Test Out - R- 16 bits - [PCI_Reg:82h]			
Field Name	Bits	Default	Description
PHY Test Output data	9:0	000h	SATA PHY receiving data (rxd9:0)
PHY receiving clock	10	0b	SATA PHY receiving clock (asicclk)
PHY receiving data valid	11	0b	SATA PHY receiving data valid (rxdvalid)
PHY receiving signal valid	12	0b	SATA PHY receiving signal valid (sglvalid)
Reserved	15:13	0h	Reserved. Still read/write-able.

PHY MODE- RW - 16 bits - [PCI_Reg:84h]			
Field Name	Bits	Default	Description
OSCDISABLE	0	0b	Set to '1' to disable PHY Crystal
SATA PHY Enable	1	1b	If set, PHY is enabled.
PHY Global ResetB	2	1b	Active low bit, clear the bit to reset all 4 ports logic in PHY.
Port0 Reset	3	0b	Set the bit to reset PHY port0 logic.
Port1 Reset	4	0b	Set the bit to reset PHY port1 logic.
Port2 Reset	5	0b	Set the bit to reset PHY port2 logic.
Port3 Reset	6	0b	Set the bit to reset PHY port3 logic.
Port4 Reset	7	0b	Set the bit to reset PHY port4 logic.
Port5 Reset	8	0b	Set the bit to reset PHY port5 logic.
TESTMODE	9	0b	Read Only Output of PHY, indicates PHY is in test mode.
Reserved	15:10	00h	Reserved. Still read/write-able.
Reset Condition: PCI Reset, or Power Management State transition from D3 to D0.			

PHY Global Register - RW- 16 bits - [PCI_Reg:86h]			
Field Name	Bits	Default	Description
PHY Global Control	15:0	2C40h	PHY global fine-tune register. Bit[6] = EXTCLKEN=1'b1, enables the 100MHz Diff Clock. Default enabled. Bit[15] has no effect, actual control in sata_core (clkssel) Bit[4] has no effect, actual logia in sata_core (refmode)
Reset Condition: PCI Reset.			

PHY Port0 Register - RW- 32 bits - [PCI_Reg:88h]								
Field Name	Bits	Default	Description					
TX main driver swing	4:0	10100b	Port0 Tx driving swing[4:0] is valid only at SATA 1.5G if bit[24]=1. It sets TX main driver swing. The user can program the optimum value for each SATA port.					
			Bit 4	Bit 3	Bit 2	Bit 1	Bit 0	Nominal Output
			1	0	0	0	0	400mv
			1	0	0	1	0	450mv
			1	0	1	0	0	500mv
			1	0	1	1	0	550mv
			1	1	0	0	0	600mv
			1	1	0	1	0	650mv
			1	1	1	0	0	700mv
			1	1	1	1	0	750mv
Note: This applies to all the ASIC Revisions A11 and above.								
TX pre-emphasis driver swing	7:5	000b	Port0 Tx driving swing[7:5] is valid only at SATA 1.5G if bit[24]=1. It sets TX pre-emphasis driver swing. The user can program the optimum pre-emphasis value for each SATA port if TX pre-emphasis enable bit turned on (bit[13]).					
			Bit 7	Bit 6	Bit 5	pre-emphasis amount		
			0	0	0	0mv		
			0	0	1	25mv		
			0	1	0	50mv		
			0	1	1	75mv		
			1	0	0	100mv		
			1	0	1	125mv		
			1	1	0	150mv		
			1	1	1	175mv		
Note: This applies to all the ASIC Revisions A11 and above.								
Port0 PHY fine-tune register	12:8	00h	PHY port0 fine-tune register.					
TX pre-emphasis enable	13	0b	Turn on TX pre-emphasis output 1: Enable pre-emphasis 0: Disable pre-emphasis					
Port0 PHY fine-tune register	23:14	2d0h	PHY port0 fine-tune register.					
Port0 3G Tune Enable	24	1b	When set, 3G PHY will have dedicated fine-tune value, specified in reg A0h.					
Reserved	31:25	00h	Reserved. Still read/write-able.					
Reset Condition: PCI Reset.								

PHY Port1 Register - RW- 32 bits - [PCI_Reg:8Ch]								
Field Name	Bits	Default	Description					
TX main swing	4:0	10100b	Port1 Tx driving swing[4:0] is valid only at SATA 1.5G if bit[24]=1. It sets TX main driver swing. The user can program the optimum value for each SATA port					
			Bit 4	Bit 3	Bit 2	Bit 1	Bit 0	Nominal Output
			1	0	0	0	0	400mv
			1	0	0	1	0	450mv
			1	0	1	0	0	500mv
			1	0	1	1	0	550mv
			1	1	0	0	0	600mv
			1	1	0	1	0	650mv
			1	1	1	0	0	700mv
			1	1	1	1	0	750mv
Note: This applies to all the ASIC Revisions A11 and above.								
TX pre-emphasis driver swing	7:5	000b	Port1 Tx driving swing[7:5] is valid only at SATA 1.5G if bit[24]=1. It sets TX pre-emphasis driver swing. The user can program the optimum pre-emphasis value for each SATA port if TX pre-emphasis enable bit turned on (bit[13]).					
			Bit 7	Bit 6	Bit 5	pre-emphasis amount		
			0	0	0	0mv		
			0	0	1	25mv		
			0	1	0	50mv		
			0	1	1	75mv		
			1	0	0	100mv		
			1	0	1	125mv		
			1	1	0	150mv		
1	1	1	175mv					
Note: This applies to all the ASIC Revisions A11 and above.								
Port1 PHY fine-tune register	12:8	00h	PHY port1 fine-tune register.					
TX pre-emphasis enable	13	0b	Turn on port1 TX pre-emphasis output 1: Enable pre-emphasis 0: Disable pre-emphasis					
Port1 PHY fine-tune register	23:14	2d0h	PHY port1 fine-tune register.					
Port1 3G Tune Enable	24	1b	When set, 3G PHY will have dedicated fine-tune value, specified in reg A2h.					
Reserved	31:25	00h	Reserved. Still read/write-able.					
Reset Condition: PCI Reset.								

PHY Port2 Register - RW- 32 bits - [PCI_Reg:90h]								
Field Name	Bits	Default	Description					
TX main swing	4:0	10100b	Port2 Tx driving swing[4:0] is valid only at SATA 1.5G if bit[24]=1. It sets TX main driver swing. The user can program the optimum value for each SATA port.					
			Bit 4	Bit 3	Bit 2	Bit 1	Bit 0	Nominal Output
			1	0	0	0	0	400mv
			1	0	0	1	0	450mv
			1	0	1	0	0	500mv
			1	0	1	1	0	550mv
			1	1	0	1	0	600mv
			1	1	0	1	0	650mv
			1	1	1	0	0	700mv
			1	1	1	1	0	750mv
Note: This applies to all the ASIC Revisions A11 and above.								
TX pre-emphasis driver swing	7:5	000b	Port2 Tx driving swing[7:5] is valid only at SATA 1.5G if bit[24]=1. It sets TX pre-emphasis driver swing. The user can program the optimum pre-emphasis value for each SATA port if TX pre-emphasis enable bit turned on (bit[13]).					
			Bit 7	Bit 6	Bit 5	pre-emphasis amount		
			0	0	0	0mv		
			0	0	1	25mv		
			0	1	0	50mv		
			0	1	1	75mv		
			1	0	0	100mv		
			1	0	1	125mv		
			1	1	0	150mv		
1	1	1	175mv					
Note: This applies to all the ASIC Revisions A11 and above.								
Port2 PHY fine-tune register	12:8	00h	PHY port2 fine-tune register.					
TX pre-emphasis enable	13	0b	Turn on port2 TX pre-emphasis output 1: Enable pre-emphasis 0: Disable pre-emphasis					
Port2 PHY fine-tune register	23:14	2d0h	PHY port2 fine-tune register.					
Port2 3G Tune Enable	24	1b	When set, 3G PHY will have dedicated fine-tune value, specified in reg A4h.					
Reserved	31:25	00h	Reserved.					
Reset Condition: PCI Reset.								

PHY Port3 Register - RW- 32 bits - [PCI_Reg:94h]								
Field Name	Bits	Default	Description					
TX main swing	4:0	10100b	Port3 Tx driving swing[4:0] is valid only at SATA 1.5G if bit[24]=1. It sets TX main driver swing. The user can program the optimum value for each SATA port.					
			Bit 4	Bit 3	Bit 2	Bit 1	Bit 0	Nominal Output
			1	0	0	0	0	400mv
			1	0	0	1	0	450mv
			1	0	1	0	0	500mv
			1	0	1	1	0	550mv
			1	1	0	0	0	600mv
			1	1	0	1	0	650mv
			1	1	1	0	0	700mv
			1	1	1	1	0	750mv
Note: This applies to all the ASIC Revisions A11 and above.								
TX pre-emphasis driver swing	7:5	000b	Port3 Tx driving swing[7:5] is valid only at SATA 1.5G if bit[24]=1. It sets TX pre-emphasis driver swing. The user can program the optimum pre-emphasis value for each SATA port if TX pre-emphasis enable bit turned on (bit[13]).					
			Bit 7	Bit 6	Bit 5	pre-emphasis amount		
			0	0	0	0mv		
			0	0	1	25mv		
			0	1	0	50mv		
			0	1	1	75mv		
			1	0	0	100mv		
			1	0	1	125mv		
			1	1	0	150mv		
1	1	1	175mv					
Note: This applies to all the ASIC Revisions A11 and above.								
Port3 PHY fine-tune register	12:8	00h	PHY port3 fine-tune register.					
TX pre-emphasis enable	13	0b	Turn on port3 TX pre-emphasis output 1: Enable pre-emphasis 0: Disable pre-emphasis					
Port3 PHY fine-tune register	23:14	2d0h	PHY port3 fine-tune register.					
Port3 3G Tune Enable	24	1b	When set, 3G PHY will have dedicated fine-tune value, specified in reg A6h.					
Reserved	31:25	00h	Reserved.					
Reset Condition: PCI Reset.								

PHY Port4 Register - RW- 32 bits - [PCI_Reg:98h]								
Field Name	Bits	Default	Description					
TX main swing	4:0	10100b	Port4 Tx driving swing[4:0] is valid only at SATA 1.5G if bit[24]=1. It sets TX main driver swing. The user can program the optimum value for each SATA port.					
			Bit 4	Bit 3	Bit 2	Bit 1	Bit 0	Nominal Output
			1	0	0	0	0	400mv
			1	0	0	1	0	450mv
			1	0	1	0	0	500mv
			1	0	1	1	0	550mv
			1	1	0	0	0	600mv
			1	1	0	1	0	650mv
			1	1	1	0	0	700mv
			1	1	1	1	0	750mv
Note: This applies to all the ASIC Revisions A11 and above.								
TX pre-emphasis driver swing	7:5	000b	Port4 Tx driving swing[7:5] is valid only at SATA 1.5G if bit[24]=1. It sets TX pre-emphasis driver swing. The user can program the optimum pre-emphasis value for each SATA port if TX pre-emphasis enable bit turned on (bit[13]).					
			Bit 7	Bit 6	Bit 5	pre-emphasis amount		
			0	0	0	0mv		
			0	0	1	25mv		
			0	1	0	50mv		
			0	1	1	75mv		
			1	0	0	100mv		
			1	0	1	125mv		
			1	1	0	150mv		
1	1	1	175mv					
Note: This applies to all the ASIC Revisions A11 and above.								
Port4 PHY fine-tune register	12:8	00h	PHY port4 fine-tune register.					
TX pre-emphasis enable	13	0b	Turn on port4 TX pre-emphasis output 1: Enable pre-emphasis 0: Disable pre-emphasis					
Port4 PHY fine-tune register	23:14	2d0h	PHY port4 fine-tune register.					
Port4 3G Tune Enable	24	1b	When set, 3G PHY will have dedicated fine-tune value, specified in reg A8h.					
Reserved	31:25	00h	Reserved.					
Reset Condition: PCI Reset.								

PHY Port5 Register - RW- 32 bits - [PCI_Reg:9Ch]								
Field Name	Bits	Default	Description					
TX main swing	4:0	10100b	Port5 Tx driving swing[4:0] is valid only at SATA 1.5G if bit[24]=1. It sets TX main driver swing. The user can program the optimum value for each SATA port.					
			Bit 4	Bit 3	Bit 2	Bit 1	Bit 0	Nominal Output
			1	0	0	0	0	400mv
			1	0	0	1	0	450mv
			1	0	1	0	0	500mv
			1	0	1	1	0	550mv
			1	1	0	0	0	600mv
			1	1	0	1	0	650mv
			1	1	1	0	0	700mv
			1	1	1	1	0	750mv
Note: This applies to all the ASIC Revisions A11 and above.								
TX pre-emphasis driver swing	7:5	000b	Port5 Tx driving swing[7:5] is valid only at SATA 1.5G if bit[24]=1. It sets TX pre-emphasis driver swing. The user can program the optimum pre-emphasis value for each SATA port if TX pre-emphasis enable bit turned on (bit[13]).					
			Bit 7	Bit 6	Bit 5	pre-emphasis amount		
			0	0	0	0mv		
			0	0	1	25mv		
			0	1	0	50mv		
			0	1	1	75mv		
			1	0	0	100mv		
			1	0	1	125mv		
			1	1	0	150mv		
1	1	1	175mv					
Note: This applies to all the ASIC Revisions A11 and above.								
Port5 PHY fine-tune register	12:8	00h	PHY port5 fine-tune register.					
TX pre-emphasis enable	13	0b	Turn on port5 TX pre-emphasis output 1: Enable pre-emphasis 0: Disable pre-emphasis					
Port5 PHY fine-tune register	23:14	2d0h	PHY port5 fine-tune register.					
Port5 3G Tune Enable	24	1b	When set, 3G PHY will have dedicated fine-tune value, specified in reg AAh.					
Reserved	31:25	00h	Reserved.					
Reset Condition: PCI Reset.								

PHY Port0 GENII Register - RW- 16 bits - [PCI_Reg:A0h]								
Field Name	Bits	Default	Description					
TX main swing	4:0	10100b	Port0 Tx driving swing[4:0] is valid only at SATA 3.0G. It sets TX main driver swing. The user can program the optimum value for each SATA port.					
			Bit 4	Bit 3	Bit 2	Bit 1	Bit 0	Nominal Output
			1	0	0	0	0	400mv
			1	0	0	1	0	450mv
			1	0	1	0	0	500mv
			1	0	1	1	0	550mv
			1	1	0	0	0	600mv
			1	1	0	1	0	650mv
			1	1	1	0	0	700mv
			1	1	1	1	0	750mv
Note: This applies to all the ASIC Revisions A11 and above.								
TX pre-emphasis driver swing	7:5	000b	Port0 Tx driving swing[7:5] is valid only at SATA 3.0G. It sets TX pre-emphasis driver swing. The user can program the optimum pre-emphasis value for each SATA port if TX pre-emphasis enable bit turned on (bit[13]).					
			Bit 7	Bit 6	Bit 5	pre-emphasis amount		
			0	0	0	0mv		
			0	0	1	25mv		
			0	1	0	50mv		
			0	1	1	75mv		
			1	0	0	100mv		
			1	0	1	125mv		
			1	1	0	150mv		
			1	1	1	175mv		
Note: This applies to all the ASIC Revisions A11 and above.								
Port0 PHY fine-tune register	12:8	00h	PHY port0 fine-tune register.					
TX pre-emphasis enable	13	0b	Turn on port0 SATA 3.0G TX pre-emphasis output 1: Enable pre-emphasis 0: Disable pre-emphasis					
Port0 PHY fine-tune register	15:14	0h	PHY port0 fine-tune register.					
Reset Condition: PCI Reset.								

PHY Port1 GENII Register - RW- 16 bits - [PCI_Reg:A2h]								
Field Name	Bits	Default	Description					
TX main swing	4:0	10100b	Port1 Tx driving swing[4:0] is valid only at SATA 3.0G. It sets TX main driver swing. The user can program the optimum value for each SATA port.					
			Bit 4	Bit 3	Bit 2	Bit 1	Bit 0	Nominal Output
			1	0	0	0	0	400mv
			1	0	0	1	0	450mv
			1	0	1	0	0	500mv
			1	0	1	1	0	550mv
			1	1	0	0	0	600mv
			1	1	0	1	0	650mv
			1	1	1	0	0	700mv
			1	1	1	1	0	750mv
Note: This applies to all the ASIC Revisions A11 and above.								

PHY Port1 GENII Register - RW- 16 bits - [PCI_Reg:A2h]			
Field Name	Bits	Default	Description
TX pre-emphasis driver swing	7:5	000b	Port1 Tx driving swing[7:5] is valid only at SATA 3.0G. It sets TX pre-emphasis driver swing. The user can program the optimum pre-emphasis value for each SATA port if TX pre-emphasis enable bit turned on (bit[13]).
			Bit 7 Bit 6 Bit 5 pre-emphasis amount
			0 0 0 0mv
			0 0 1 25mv
			0 1 0 50mv
			0 1 1 75mv
			1 0 0 100mv
			1 0 1 125mv
			1 1 0 150mv
			1 1 1 175mv
			Note: This applies to all the ASIC Revisions A11 and above.
Port1 PHY fine-tune register	12:8	00h	PHY port1 fine-tune register.
TX pre-emphasis enable	13	0b	Turn on port1 SATA 3.0G TX pre-emphasis output 1: Enable pre-emphasis 0: Disable pre-emphasis
Port1 PHY fine-tune register	15:14	0h	PHY port1 fine-tune register.
Reset Condition: PCI Reset.			

PHY Port2 GENII Register - RW- 16 bits - [PCI_Reg:A4h]			
Field Name	Bits	Default	Description
TX main swing	4:0	10100b	Port2 Tx driving swing[4:0] is valid only at SATA 3.0G. It sets TX main driver swing. The user can program the optimum value for each SATA port.
			Bit 4 Bit 3 Bit 2 Bit 1 Bit 0 Nominal Output
			1 0 0 0 0 400mv
			1 0 0 1 0 450mv
			1 0 1 0 0 500mv
			1 0 1 1 0 550mv
			1 1 0 0 0 600mv
			1 1 0 1 0 650mv
			1 1 1 0 0 700mv
			1 1 1 1 0 750mv
			Note: This applies to all the ASIC Revisions A11 and above.
TX pre-emphasis driver swing	7:5	000b	Port2 Tx driving swing[7:5] is valid only at SATA 3.0G. It sets TX pre-emphasis driver swing. The user can program the optimum pre-emphasis value for each SATA port if TX pre-emphasis enable bit turned on (bit[13]).
			Bit 7 Bit 6 Bit 5 pre-emphasis amount
			0 0 0 0mv
			0 0 1 25mv
			0 1 0 50mv
			0 1 1 75mv
			1 0 0 100mv
			1 0 1 125mv
			1 1 0 150mv
			1 1 1 175mv
			Note: This applies to all the ASIC Revisions A11 and above.

PHY Port2 GENII Register - RW- 16 bits - [PCI_Reg:A4h]			
Field Name	Bits	Default	Description
Port2 PHY fine-tune register	12:8	00h	PHY port2 fine-tune register.
TX pre-emphasis enable	13	0b	Turn on port2 SATA 3.0G TX pre-emphasis output 1: Enable pre-emphasis 0: Disable pre-emphasis
Port2 PHY fine-tune register	15:14	0h	PHY port2 fine-tune register.
Reset Condition: PCI Reset.			

PHY Port3 GENII Register - RW- 16 bits - [PCI_Reg:A6h]								
Field Name	Bits	Default	Description					
TX main swing	4:0	10100b	Port3 Tx driving swing[4:0] is valid only at SATA 3.0G. It sets TX main driver swing. The user can program the optimum value for each SATA port.					
			Bit 4	Bit 3	Bit 2	Bit 1	Bit 0	Nominal Output
			1	0	0	0	0	400mv
			1	0	0	1	0	450mv
			1	0	1	0	0	500mv
			1	0	1	1	0	550mv
			1	1	0	0	0	600mv
			1	1	0	1	0	650mv
			1	1	1	0	0	700mv
			1	1	1	1	0	750mv
Note: This applies to all the ASIC Revisions A11 and above.								
TX pre-emphasis driver swing	7:5	000b	Port3 Tx driving swing[7:5] is valid only at SATA 3.0G. It sets TX pre-emphasis driver swing. The user can program the optimum pre-emphasis value for each SATA port if TX pre-emphasis enable bit turned on (bit[13]).					
			Bit 7	Bit 6	Bit 5	pre-emphasis amount		
			0	0	0	0mv		
			0	0	1	25mv		
			0	1	0	50mv		
			0	1	1	75mv		
			1	0	0	100mv		
			1	0	1	125mv		
			1	1	0	150mv		
1	1	1	175mv					
Note: This applies to all the ASIC Revisions A11 and above.								
Port3 PHY fine-tune register	12:8	00h	PHY port3 fine-tune register.					
TX pre-emphasis enable	13	0b	Turn on port3 SATA 3.0G TX pre-emphasis output 1: Enable pre-emphasis 0: Disable pre-emphasis					
Port3 PHY fine-tune register	15:14	0h	PHY port3 fine-tune register.					
Reset Condition: PCI Reset.								

PHY Port4 GENII Register - RW- 16 bits - [PCI_Reg:A8h]								
Field Name	Bits	Default	Description					
TX main swing	4:0	10100b	Port4 Tx driving swing[4:0] is valid only at SATA 3.0G. It sets TX main driver swing. The user can program the optimum value for each SATA port.					
			Bit 4	Bit 3	Bit 2	Bit 1	Bit 0	Nominal Output
			1	0	0	0	0	400mv
			1	0	0	1	0	450mv
			1	0	1	0	0	500mv
			1	0	1	1	0	550mv
			1	1	0	0	0	600mv
			1	1	0	1	0	650mv
			1	1	1	0	0	700mv
			1	1	1	1	0	750mv
Note: This applies to all the ASIC Revisions A11 and above.								
TX pre-emphasis driver swing	7:5	000b	Port4 Tx driving swing[7:5] is valid only at SATA 3.0G. It sets TX pre-emphasis driver swing. The user can program the optimum pre-emphasis value for each SATA port if TX pre-emphasis enable bit turned on (bit[13]).					
			Bit 7	Bit 6	Bit 5	pre-emphasis amount		
			0	0	0	0mv		
			0	0	1	25mv		
			0	1	0	50mv		
			0	1	1	75mv		
			1	0	0	100mv		
			1	0	1	125mv		
			1	1	0	150mv		
			1	1	1	175mv		
Note: This applies to all the ASIC Revisions A11 and above.								
Port4 PHY fine-tune register	12:8	00h	PHY port4 fine-tune register.					
TX pre-emphasis enable	13	0b	Turn on port4 SATA 3.0G TX pre-emphasis output 1: Enable pre-emphasis 0: Disable pre-emphasis					
Port4 PHY fine-tune register	15:14	0h	PHY port4 fine-tune register.					
Reset Condition: PCI Reset.								

PHY Port5 GENII Register - RW- 16 bits - [PCI_Reg:AAh]								
Field Name	Bits	Default	Description					
TX main swing	4:0	10100b	Port5 Tx driving swing[4:0] is valid only at SATA 3.0G. It sets TX main driver swing. The user can program the optimum value for each SATA port.					
			Bit 4	Bit 3	Bit 2	Bit 1	Bit 0	Nominal Output
			1	0	0	0	0	400mv
			1	0	0	1	0	450mv
			1	0	1	0	0	500mv
			1	0	1	1	0	550mv
			1	1	0	0	0	600mv
			1	1	0	1	0	650mv
			1	1	1	0	0	700mv
			1	1	1	1	0	750mv
Note: This applies to all the ASIC Revisions A11 and above.								

PHY Port5 GENII Register - RW- 16 bits - [PCI_Reg:AAh]						
Field Name	Bits	Default	Description			
TX pre-emphasis driver swing	7:5	000b	Port5 Tx driving swing[7:5] is valid only at SATA 3.0G. It sets TX pre-emphasis driver swing. The user can program the optimum pre-emphasis value for each SATA port if TX pre-emphasis enable bit turned on (bit[13]).			
			Bit 7	Bit 6	Bit 5	pre-emphasis amount
			0	0	0	0mv
			0	0	1	25mv
			0	1	0	50mv
			0	1	1	75mv
			1	0	0	100mv
			1	0	1	125mv
			1	1	0	150mv
			175mv			
			Note: This applies to all the ASIC Revisions A11 and above.			
Port5 PHY fine-tune register	12:8	00h	PHY port5 fine-tune register.			
TX pre-emphasis enable	13	0b	Turn on port5 SATA 3.0G TX pre-emphasis output 1: Enable pre-emphasis 0: Disable pre-emphasis			
Port5 PHY fine-tune register	15:14	0h	PHY port5 fine-tune register.			
Reset Condition: PCI Reset.						

Port0 BIST Error Count - R – 32 bits - [PCI_Reg:ACh]			
Field Name	Bits	Default	Description
Port0 BIST Error Counter	31:0	0000_0000h	When reach FFFFFFFFh, the counter value will stay at FFFFFFFFh.
Reset Condition: PCI Reset, or Power Management State transition from D3 to D0, or BIST Error Count Reset.			

Port0 BIST Control/Status - RW - 16 bits - [PCI_Reg:B0h]			
Field Name	Bits	Default	Description
Port0 Link BIST Enable	0	0b	Once set, put port0 into Link BIST mode, override normal operation.
Port0 Link BIST Speed	1	0b	PHY Port0 speed control for Link BIST mode. When set, GENII is used. If reset, GENI is used.
Port0 Link BIST pattern	5:2	0000b	0000: Pseudorandom with ALIGN insertion (when Error Count is used, must choose this pattern). 0001: D10.2 Highest frequency (for Rx eye diagram measurement). 0010: SYNC primitive (for Rx eye diagram measurement). 0011: Lone Bit Pattern (LBP) 0100: Mid Frequency Test Pattern (MFTP) 0101: 20 bit data pattern, programmed at PCI_Reg:F0h. 0110: Force Far End Retimed Loop Back Mode in HBA. 0111: T-mode enable. T-mode is defined as “Far end transmit only mode without Device initiating”. In T-mode, the BIST pattern that is generated is based on the programming in the BIST Transmit Pattern Registers DW1 (0xE4) and DW2 (0xE8).
Port0 Error Count Reset	6	0b	When set, BIST error counter and Link BIST Done are reset. This bit needs to be set for 10ms, then negated. 10ms is to ensure PHY is ready in proper frequency, mode and round trip latency.

Port0 BIST Control/Status - RW - 16 bits - [PCI_Reg:B0h]			
Field Name	Bits	Default	Description
Port0 BIST Error Count Freeze Mode	7	0b	When set, BIST Error Count will stop increment if BIST Error Count Hold is set. When reset, BIST Error Count will stop increment if Link BIST Done is set.
Port0 BIST Error Count Hold	8	0b	When set, the BIST error counter will hold the current value. It won't be increased even on the event of mis-comparison. When clear, it has no affect on BIST error counter.
Port0 BIST Done	9	0b	Read Only When set, means BIST has verified x amount patterns specified in the BIST pattern Count. Will be reset by BIST Error Count Reset.
Port0 SATA BIST Enable	10	0b	Enable SATA BIST Vendor Mode: for using AR0/BAR2 offset0 (IDE Data Port) to initiate BIST active FIS.
Port0 BIST with disconnect Enable	11	0b	When set and a BIST Activate FIS is received from the device, the HBA will ignore all OOB signaling from the device. The HBA can exit this mode either thru a hardware reset or a software initiated COMRESET. Note: This bit will not be cleared from a software initiated COMRESET.
Reserved	15:12	0h	Reserved. Still read/writeable.
Reset Condition: PCI Reset, or Power Management State transition from D3 to D0. Note: Reset Condition for bit [15:11] is PCI Reset.			

Port1 BIST Error Count - R - 32 bits - [PCI_Reg:B4h]			
Field Name	Bits	Default	Description
Port1 BIST Error Counter	31:0	0000_0000h	When reach FFFFFFFFh, the counter value will stay at FFFFFFFFh.
Reset Condition: PCI Reset, or Power Management State transition from D3 to D0, or BIST Error Count Reset.			

Port1 BIST Control/Status - RW - 16 bits - [PCI_Reg:B8h]			
Field Name	Bits	Default	Description
Port1 Link BIST Enable	0	0b	Once set, put port1 into Link BIST mode, override normal operation.
Port1 Link BIST Speed	1	0b	PHY Port1 speed control for Link BIST mode. When set, GENII is used. If reset, GENI is used.
Port1 Link BIST pattern	5:2	0000b	0000: Pseudorandom with ALIGN insertion (when Error Count is used, must choose this pattern). 0001: D10.2 Highest frequency (for Rx eye diagram measurement). 0010: SYNC primitive (for Rx eye diagram measurement). 0011: Lone Bit Pattern (LBP) 0100: Mid Frequency Test Pattern (MFTP) 0101: 20 bit data pattern, programmed at PCI_Reg:F0h. 0110: Force Far End Retimed Loop Back Mode in HBA. 0111: T-mode enable. T-mode is defined as "Far end transmit only mode without Device initiating". In T-mode, the BIST pattern that is generated is based on the programming in the BIST Transmit Pattern Registers DW1 (0xE4) and DW2 (0xE8).
Port1 Error Count Reset	6	0b	When set, BIST error counter and Link BIST Done are reset. This bit needs to be set for 10ms, then negated. 10ms is to ensure PHY is ready in proper frequency, mode and round trip latency.
Port1 BIST Error Count Freeze Mode	7	0b	When set, BIST Error Count will stop increment if BIST Error Count Hold is set. When reset, BIST Error Count will stop increment if Link BIST Done is set.

Port1 BIST Control/Status - RW - 16 bits - [PCI_Reg:B8h]			
Field Name	Bits	Default	Description
Port1 BIST Error Count Hold	8	0b	When set, the BIST error counter will hold the current value. It won't be increased even on the event of mis-comparison. When clear, it has no affect on BIST error counter.
Port1 BIST Done	9	0b	Read Only When set, means BIST has verified certain amount patterns specified in the BIST pattern Count. Will be reset by BIST Error Count Reset.
Port1 SATA BIST Enable	10	0b	Enable SATA BIST Vendor Mode: for using AR0/BAR2 offset0 (IDE Data Port) to initiate BIST active FIS.
Port1 BIST with disconnect Enable	11	0b	When set and a BIST Activate FIS is received from the device, the HBA will ignore all OOB signaling from the device. The HBA can exit this mode either thru a hardware reset or a software initiated COMRESET. Note: This bit will not be cleared from a software initiated COMRESET.
Reserved	15:12	0h	Reserved. Still read/writeable.
Reset Condition: PCI Reset, or Power Management State transition from D3 to D0. Note: Reset Condition for bit [15:11] is PCI Reset.			

Port2 BIST Error Count - R - 32 bits - [PCI_Reg:BCh]			
Field Name	Bits	Default	Description
Port2 BIST Error Counter	31:0	0000_0000h	When reach FFFFFFFFh, the counter value will stay at FFFFFFFFh.
Reset Condition: PCI Reset, or Power Management State transition from D3 to D0, or BIST Error Count Reset.			

Port2 BIST Control/Status - RW - 16 bits - [PCI_Reg:C0h]			
Field Name	Bits	Default	Description
Port2 Link BIST Enable	0	0b	Once set, put port2 into Link BIST mode, override normal operation.
Port2 Link BIST Speed	1	0b	PHY Port2 speed control for Link BIST mode. When set, GENII is used. If reset, GENI is used.
Port2 Link BIST pattern	5:2	0000b	0000: Pseudorandom with ALIGN insertion (when Error Count is used, must choose this pattern). 0001: D10.2 Highest frequency (for Rx eye diagram measurement). 0010: SYNC primitive (for Rx eye diagram measurement). 0011: Lone Bit Pattern (LBP) 0100: Mid Frequency Test Pattern (MFTP) 0101: 20 bit data pattern, programmed at PCI_Reg:F0h. 0110: Force Far End Retimed Loop Back Mode in HBA. 0111: T-mode enable. T-mode is defined as "Far end transmit only mode without Device initiating". In T-mode, the BIST pattern that is generated is based on the programming in the BIST Transmit Pattern Registers DW1 (0xE4) and DW2 (0xE8).
Port2 BIST Error Count Reset	6	0b	When set, BIST error counter and Link BIST Done are reset. This bit needs to be set for 10ms, then negated. 10ms is to ensure PHY is ready in proper frequency, mode and round trip latency.
Port2 BIST Error Count Freeze Mode	7	0b	When set, Link BIST Error Count will stop increment if Link BIST Error Count Hold is set. When reset, Link BIST Error Count will stop increment if Link BIST Done is set.
Port2 BIST Error Count Hold	8	0b	When set, the BIST error counter will hold the current value. It won't be increased even on the event of mis-comparison. When clear, it has no affect on BIST error counter.

Port2 BIST Control/Status - RW - 16 bits - [PCI_Reg:C0h]			
Field Name	Bits	Default	Description
Port2 BIST Done	9	0b	Read Only When set, means BIST has verified certain amount patterns specified in the BIST pattern Count. Will be reset by BIST Error Count Reset.
Port2 SATA BIST Enable	10	0b	Enable SATA BIST Vendor Mode: for using AR0/BAR2 offset0 (IDE Data Port) to initiate BIST active FIS.
Port2 BIST with disconnect Enable	11	0b	When set and a BIST Activate FIS is received from the device, the HBA will ignore all OOB signaling from the device. The HBA can exit this mode either thru a hardware reset or a software initiated COMRESET. Note: This bit will not be cleared from a software initiated COMRESET.
Reserved	15:12	0h	Reserved. Still read/writeable.
Reset Condition: PCI Reset, or Power Management State transition from D3 to D0. Note: Reset Condition for bit [15:12] is PCI Reset.			

Port3 BIST Error Count - R - 32 bits - [PCI_Reg:C4h]			
Field Name	Bits	Default	Description
Port3 BIST Error Counter	31:0	0000_0000h	When reach FFFFFFFFh, the counter value will stay at FFFFFFFFh.
Reset Condition: PCI Reset, or Power Management State transition from D3 to D0, or BIST Error Count Reset.			

Port3 BIST Control/Status - RW - 16 bits - [PCI_Reg:C8h]			
Field Name	Bits	Default	Description
Port3 Link BIST Enable	0	0b	Once set, put port3 into Link BIST mode, override normal operation.
Port3 Link BIST Speed	1	0b	PHY Port3 speed control for Link BIST mode. When set, GENII is used. If reset, GENI is used.
Port3 Link BIST pattern	5:2	0000b	0000: Pseudorandom with ALIGN insertion (when Error Count is used, must choose this pattern). 0001: D10.2 Highest frequency (for Rx eye diagram measurement). 0010: SYNC primitive (for Rx eye diagram measurement). 0011: Lone Bit Pattern (LBP) 0100: Mid Frequency Test Pattern (MFTP) 0101: 20 bit data pattern, programmed at PCI_Reg:F0h. 0110: Force Far End Retimed Loop Back Mode in HBA. 0111: T-mode enable. T-mode is defined as "Far end transmit only mode without Device initiating". In T-mode, the BIST pattern that is generated is based on the programming in the BIST Transmit Pattern Registers DW1 (0xE4) and DW2 (0xE8).
Port3 BIST Error Count Reset	6	0b	When set, BIST error counter and Link BIST Done are reset. This bit needs to be set for 10ms, then negated. 10ms is to ensure PHY is ready in proper frequency, mode and round trip latency.
Port3 BIST Error Count Freeze Mode	7	0b	When set, BIST Error Count will stop increment if BIST Error Count Hold is set. When reset, BIST Error Count will stop increment if BIST Done is set.
Port3 BIST Error Count Hold	8	0b	When set, the BIST error counter will hold the current value. It won't be increased even on the event of mis-comparison. When clear, it has no affect on BIST error counter.
Port3 BIST Done	9	0b	Read Only When set, means BIST has verified certain amount patterns specified in the BIST pattern Count. Will be reset by BIST Error Count Reset.

Port3 BIST Control/Status - RW - 16 bits - [PCI_Reg:C8h]			
Field Name	Bits	Default	Description
Port3 SATA BIST Enable	10	0b	Enable SATA BIST Vendor Mode: for using AR0/BAR2 offset0 (IDE Data Port) to initiate BIST active FIS.
Port3 BIST with disconnect Enable	11	0b	When set and a BIST Activate FIS is received from the device, the HBA will ignore all OOB signaling from the device. The HBA can exit this mode either thru a hardware reset or a software initiated COMRESET. Note: This bit will not be cleared from a software initiated COMRESET.
Reserved	15:12	0h	Reserved. Still read/writeable.
Reset Condition: PCI Reset, or Power Management State transition from D3 to D0. Note: Reset Condition for bit [15:12] is PCI Reset.			

Port4 BIST Error Count - R - 32 bits - [PCI_Reg:CCh]			
Field Name	Bits	Default	Description
Port4 BIST Error Counter	31:0	0000_0000h	When reach FFFFFFFFh, the counter value will stay at FFFFFFFFh.
Reset Condition: PCI Reset, or Power Management State transition from D3 to D0, or BIST Error Count Reset.			

Port4 BIST Control/Status - RW - 16 bits - [PCI_Reg:D0h]			
Field Name	Bits	Default	Description
Port4 Link BIST Enable	0	0b	Once set, put port4 into Link BIST mode, override normal operation.
Port4 Link BIST Speed	1	0b	PHY Port4 speed control for Link BIST mode. When set, GENII is used. If reset, GENI is used.
Port4 Link BIST pattern	5:2	0000b	0000: Pseudorandom with ALIGN insertion (when Error Count is used, must choose this pattern). 0001: D10.2 Highest frequency (for Rx eye diagram measurement). 0010: SYNC primitive (for Rx eye diagram measurement). 0011: Lone Bit Pattern (LBP) 0100: Mid Frequency Test Pattern (MFTP) 0101: 20 bit data pattern, programmed at PCI_Reg:F0h. 0110: Force Far End Retimed Loop Back Mode in HBA. 0111: T-mode enable. T-mode is defined as "Far end transmit only mode without Device initiating". In T-mode, the BIST pattern that is generated is based on the programming in the BIST Transmit Pattern Registers DW1 (0xE4) and DW2 (0xE8).
Port4 BIST Error Count Reset	6	0b	When set, BIST error counter and Link BIST Done are reset. This bit needs to be set for 10ms, then negated. 10ms is to ensure PHY is ready in proper frequency, mode and round trip latency.
Port4 BIST Error Count Freeze Mode	7	0b	When set, BIST Error Count will stop increment if BIST Error Count Hold is set. When reset, BIST Error Count will stop increment if BIST Done is set.
Port4 BIST Error Count Hold	8	0b	When set, the BIST error counter will hold the current value. It won't be increased even on the event of mis-comparison. When clear, it has no affect on BIST error counter.
Port4 BIST Done	9	0b	Read Only When set, means BIST has verified certain amount patterns specified in the BIST pattern Count. Will be reset by BIST Error Count Reset.
Port4 SATA BIST Enable	10	0b	Enable SATA BIST Vendor Mode: for using AR0/BAR2 offset0 (IDE Data Port) to initiate BIST active FIS.

Port4 BIST Control/Status - RW - 16 bits - [PCI_Reg:D0h]			
Field Name	Bits	Default	Description
Port4 BIST with disconnect Enable	11	0b	When set and a BIST Activate FIS is received from the device, the HBA will ignore all OOB signaling from the device. The HBA can exit this mode either thru a hardware reset or a software initiated COMRESET. Note: This bit will not be cleared from a software initiated COMRESET.
Reserved	15:12	0h	Reserved. Still read/writeable.
Reset Condition: PCI Reset, or Power Management State transition from D3 to D0. Note: Reset Condition for bit [15:12] is PCI Reset.			

Port5 BIST Error Count - R - 32 bits - [PCI_Reg:D4h]			
Field Name	Bits	Default	Description
Port5 BIST Error Counter	31:0	0000_0000h	When reach FFFFFFFFh, the counter value will stay at FFFFFFFFh.
Reset Condition: PCI Reset, or Power Management State transition from D3 to D0, or BIST Error Count Reset.			

Port5 BIST Control/Status - RW - 16 bits - [PCI_Reg:D8h]			
Field Name	Bits	Default	Description
Port5 Link BIST Enable	0	0b	Once set, put port5 into Link BIST mode, and override normal operation.
Port5 Link BIST Speed	1	0b	PHY Port5 speed control for Link BIST mode. When set, GENII is used. If reset, GENI is used.
Port5 Link BIST pattern	5:2	0000b	0000: Pseudorandom with ALIGN insertion (when Error Count is used, must choose this pattern). 0001: D10.2 Highest frequency (for Rx eye diagram measurement). 0010: SYNC primitive (for Rx eye diagram measurement). 0011: Lone Bit Pattern (LBP) 0100: Mid Frequency Test Pattern (MFTP) 0101: 20 bit data pattern, programmed at PCI_Reg:F0h. 0110: Force Far End Retimed Loop Back Mode in HBA. 0111: T-mode enable. T-mode is defined as "Far end transmit only mode without Device initiating". In T-mode, the BIST pattern that is generated is based on the programming in the BIST Transmit Pattern Registers DW1 (0xE4) and DW2 (0xE8).
Port5 BIST Error Count Reset	6	0b	When set, BIST error counter and Link BIST Done are reset. This bit needs to be set for 10ms, then negated. 10ms is to ensure PHY is ready in proper frequency, mode and round trip latency.
Port5 BIST Error Count Freeze Mode	7	0b	When set, BIST Error Count will stop increment if BIST Error Count Hold is set. When reset, BIST Error Count will stop increment if BIST Done is set.
Port5 BIST Error Count Hold	8	0b	When set, the BIST error counter will hold the current value. It won't be increased even on the event of mis-comparison. When clear, it has no affect on BIST error counter.
Port5 BIST Done	9	0b	Read Only When set, means BIST has verified certain amount patterns specified in the BIST pattern Count. Will be reset by BIST Error Count Reset.
Port5 SATA BIST Enable	10	0b	Enable SATA BIST Vendor Mode: for using AR0/BAR2 offset0 (IDE Data Port) to initiate BIST active FIS.

Port5 BIST Control/Status - RW - 16 bits - [PCI_Reg:D8h]			
Field Name	Bits	Default	Description
Port5 BIST with disconnect Enable	11	0b	When set and a BIST Activate FIS is received from the device, the HBA will ignore all OOB signaling from the device. The HBA can exit this mode either thru a hardware reset or a software initiated COMRESET. Note: This bit will not be cleared from a software initiated COMRESET.
Reserved	15:12	0h	Reserved. Still read/writeable.
Reset Condition: PCI Reset, or Power Management State transition from D3 to D0. Note: Reset Condition for bit [15:12] is PCI Reset.			

BIST Pattern Count - RW - 32 bits - [PCI_Reg:DCh]			
Field Name	Bits	Default	Description
BIST Pattern Count	31:0	0000_2000h	This count specifies how many Octal WORD pattern need to be checked before BIST Done bit be set. This count value is used fro all the 4 ports. 400h default value would be used for tester, which means 32K DWORD pattern would be compared for BIST test. Value of "0000_0000"h means the maximum patterns (16,000, 000, 000) checked. This register is used for both SATA BIST and Link BIST.
Reset Condition: PCI Reset, or Power Management State transition from D3 to D0.			

PCI Target Control TimeOut- RW - 16 bits - [PCI_Reg:E0h]			
Field Name	Bits	Default	Description
PCI Target Control TimeOut Count	7:0	80h	This register is used for programming the PCI Target Control TimeOut Count used to clear any stale target commands to the hosts controller. Granularity is 15.5us (Count * 15.5 us) The counter will be disabled if the count is programmed to 0x0.
Reserved	15:8	00h	Reserved.
Reset Condition: PCI Reset, or Power Management State transition from D3 to D0.			

T-Mode BIST Transit Pattern DW1 - RW - 32 bits - [PCI_Reg:E4h]			
Field Name	Bits	Default	Description
T-mode BIST Transit Pattern DW1	31:0	0000_0000h	Transit Patterns DW1
Reset Condition: PCI Reset, or Power Management State transition from D3 to D0			

T-Mode BIST Transit Pattern DW2 - RW - 32 bits - [PCI_Reg:E8h]			
Field Name	Bits	Default	Description
T-mode BIST Transit Pattern DW2	31:0	0000_0000h	Transit Patterns DW2
Reset Condition: PCI Reset, or Power Management State transition from D3 to D0			

BIST Transit Pattern Definition- RW - 16 bits - [PCI_Reg:ECh]			
Field Name	Bits	Default	Description
T-mode A bit	0	0b	ALIGN primitive bypass mode
T-mode S bit	1	0b	Scrambling Bypass.
T-mode P bit	2	0b	The transmit primitives bit.
Reserved	31:3	0000_0000h	Reserved. Still read/writeable.
Reset Condition: PCI Reset, or Power Management State transition from D3 to D0			

20-BIT BIST Transit Pattern - RW - 24 bits - [PCI_Reg:F0h]			
Field Name	Bits	Default	Description
20-BIT BIST Transit Pattern	19:0	0_0000h	20 bit Transit Data Patterns without going through 8b/10b encode.
Reserved	31:20	000h	Reserved. Still read/writable.
Reset Condition: PCI Reset, or Power Management State transition from D3 to D0			

Spare Register - RW - 8 bits - [PCI_Reg:F4h]			
Field Name	Bits	Default	Description
Reserved	7:0	00h	Reserved. Still read/writable.
Reset Condition: PCI Reset, or Power Management State transition from D3 to D0			

Spare Register1 - RW - 32 bits - [PCI_Reg:F8h]			
Field Name	Bits	Default	Description
Spare register1	31:0	0000_0000h	Reserved and can be read/writeable
Reset Condition: PCI Reset, or Power Management State transition from D3 to D0			

Spare Register2 - RW - 32 bits - [PCI_Reg:FCh]			
Field Name	Bits	Default	Description
Spare register2	31:0	0000_0000h	Reserved and can be read/writeable
Reset Condition: PCI Reset, or Power Management State transition from D3 to D0			

2.1.2 SATA I/O Register for IDE Mode

2.1.2.1 BAR0/BAR2/BAR1/BAR3 Registers

BAR0/BAR2 uses 8 bytes of I/O space. BAR0 is used for Primary channel and BAR2 is used for Secondary channel during IDE native mode. BAR1/BAR3 uses 2 bytes of I/O space. BAR1 is used for Primary channel and BAR3 is used for Secondary channel during IDE native mode.

Address (hex)		Name and Function		
Compatibility Mode		Native Mode (Offset)	Read Function	Write Function
IDE Command Block Registers				
Primary	Secondary	BAR0/BAR2		
1F0	170	(Primary or Secondary) Base Address 0 + 0	Data (16 bit)	Data (16 bit)
1F1	171	(Primary or Secondary) Base Address 0 + 1	Error register	Features register
1F2	172	(Primary or Secondary) Base Address 0 + 2	Sector Count	Sector Count
1F3	173	(Primary or Secondary) Base Address + 3	Sector Number	Sector Number
1F4	174	(Primary or Secondary) Base Address + 4	Cylinder Low	Cylinder Low
1F5	175	(Primary or Secondary) Base Address + 5	Cylinder High	Cylinder High
1F6	176	(Primary or Secondary) Base Address + 6	Drive/Head	Drive/Head
1F7	177	(Primary or Secondary) Base Address + 7	Status	Command
IDE Control Block Registers				
Primary	Secondary	BAR1/BAR3		
3F6	376	(Primary or Secondary) Base Address + 2	Alternate Status	Device Control

2.1.2.2 BAR4 Registers

BAR4 uses 16 bytes of I/O space. The Bus-master interface base address register (BAR4) defines the base address of the IO spare.

Register Name	Offset Address [Primary/Secondary]
Bus-master IDE Command	00h/08h
Bus-master IDE Status	02h/0Ah
Descriptor Table Pointer	04h/0Ch

Bus-master IDE Command - RW- 8 bits - [IO_Reg: BAR4 + 00/08h]			
Field Name	Bits	Default	Description
Bus Master IDE Start/Stop	0	0b	Bus Master IDE Start (1)/Stop (0). This bit will not be reset by interrupt from IDE device. This must be reset by soft ware (device driver).
Reserved	2:1	0h	Reserved.
Bus Master Read/Write	3	0b	Bus Master IDE r/w (direction) control 0: Memory -> IDE 1: IDE -> Memory This bit should not change during Bus Master transfer cycle, even if terminated by Bus Master IDE stop.
Reserved	7:4	0h	Reserved.

Bus-master IDE Status - RW- 8 bits - [IO_Reg: BAR4 + 02/0Ah]			
Field Name	Bits	Default	Description
Bus Master Active	0	0b	Bus Master IDE active. This bit is set to 1 when bit 0 in the Bus Master IDE command address register is set to 1. The IDE host controller sets this bit to 0 when the last transfer for a region is performed. This bit is also set to 0 when bit 0 of the Bus Master IDE command register is set to 0.
Bus Master DMA Error	1	0b	IDE DMA error. This bit is set when the IDE host controller encounters a target abort, master abort, or Parity error while transferring data on the PCI bus. Write 1 clears this bit.
IDE Interrupt	2	0b	IDE Interrupt. Indicates when an IDE device has asserted its interrupt line. IRQ14 is used for the Primary channel and IRQ15 is used for the secondary channel. If the interrupt status bit is set to 0, by writing a 1 to this bit while the interrupt line is still at the active level, this bit remains 0 until another assertion edge is detected on the interrupt line.
Reserved	4:3	0h	Reserved.
Master Device DMA Capable	5	0b	Device 0 (Master) DMA capable.
Slave Device DMA Capable	6	0b	Device 1 (Slave) DMA capable.
Simplex Only	7	0b	Read Only. Simplex only. This bit is hard-wired as 0.

Descriptor Table Pointer - RW- 32 bits - [IO_Reg: BAR4 + 04/0Ch]			
Field Name	Bits	Default	Description
Reserved	1:0	0h	Reserved.
Descriptor Table Base Address	31:2	0000_0000h	Base Address of Descriptor Table. These bits correspond to Address [31-02].

2.1.3 SATA Memory Mapped Register for AHCI Mode

2.1.3.1 BAR5 Registers

These are the AHCI memory map registers. The base address is defined through ABAR (BAR5) register

Register Name	Offset Address
Generic Host Control	00h-23h
<i>Reserved</i>	24h-9Fh
Vendor Specific registers	A0h-FFh
Port 0 port control registers	100h-17Fh
Port 1 port control registers	180h-1FFh
Port 2 port control registers	200h-27Fh
Port 3 port control registers	280h-2FFh
Port 4 port control registers	300h-37Fh
Port 5 port control registers	380h-3FFh

2.1.3.2 Generic Host Control

The following registers apply to the entire HBA.

Register Name	Offset Address
Host Capabilities(CAP)	00h-03h
Global Host Control(GHC)	04h-07h
Interrupt Status(IS)	08h-0Bh
Ports Implemented(PI)	0Ch-0Fh
Version(VS)	10h-13h
Command Completion Coalescing Control(CCC_CTL)	14h-17h
Command Completion Coalescing Ports(CCC_PORTS)	18h-1Bh
Enclosure Management Location(EM_LOC)	1Ch-1Fh
Enclosure Management Control(EM_CTL)	20h-23h
vendor specific	A0h-FFh

2.1.3.3 Offset 00h: CAP – HBA Capabilities

This register indicates the basic capabilities of the HBA to driver software.

HBA Capabilities – R - 32bits [Mem_reg: ABAR + 00h]			
Field Name	Bits	Default	Description
Number of Ports	4:0	00101b	0's based value indicating the maximum number of ports supported by the HBA silicon. A maximum of 32 ports can be supported. A value of '0h', indicating one port, is the minimum requirement. Note that the number of ports indicated in this field may be more than the number of ports indicated in the GHC.PI register.
Supports External SATA (SXS)	5	0b	When set to '1', indicates that the HBA has one or more Serial ATA ports that has a signal only connector that is externally accessible. If this bit is set to '1', software may refer to the PxCMD.ESP bit to determine whether a specific port has its signal connector externally accessible as a signal only connector (i.e. power is not part of that connector). When the bit is cleared to '0', indicates that the HBA has no Serial ATA ports that have a signal only connector externally accessible.
Enclosure Management Supported (EMS)	6	0b	When set to '1', indicates that the HBA supports enclosure management. When enclosure management is supported, the HBA has implemented the EM_LOC and EM_CTL global HBA registers. When cleared to '0', indicates that the HBA does not support enclosure management and the EM_LOC and EM_CTL global HBA registers are not implemented.
Command Completion Coalescing Supported (CCCS)	7	1b	When set to '1', indicates that the HBA supports command completion coalescing. When command completion coalescing is supported, the HBA has implemented the CCC_CTL and the CCC_PORTS global HBA registers. When cleared to '0', indicates that the HBA does not support command completion coalescing and the CCC_CTL and CCC_PORTS global HBA registers are not implemented.
Number of Command Slots (NCS)	12:8	11111b	0's based value indicating the number of command slots per port supported by this HBA. A minimum of 1 and maximum of 32 slots per port can be supported. The same number of command slots is available on each implemented port.

HBA Capabilities – R - 32bits [Mem_reg: ABAR + 00h]													
Field Name	Bits	Default	Description										
Partial State Capable (PSC):	13	1b	Indicates whether the HBA can support transitions to the Partial state. When cleared to '0', software must not allow the HBA to initiate transitions to the Partial state via aggressive link power management nor the PxCMD.ICC field in each port, and the PxSCTL.IPM field in each port must be programmed to disallow device initiated Partial requests. When set to '1', HBA and device initiated Partial requests can be supported.										
Slumber State Capable (SSC):	14	1b	Indicates whether the HBA can support transitions to the Slumber state. When cleared to '0', software must not allow the HBA to initiate transitions to the Slumber state via aggressive link power management nor the PxCMD.ICC field in each port, and the PxSCTL.IPM field in each port must be programmed to disallow device initiated Slumber requests. When set to '1', HBA and device initiated Slumber requests can be supported.										
PIO Multiple DRQ Block (PMD)	15	1b	If set to '1', the HBA supports multiple DRQ block data transfers for the PIO command protocol. If cleared to '0' the HBA only supports single DRQ block data transfers for the PIO command protocol.										
FIS-based Switching Supported (FBSS)	16	0b	When set to '1', indicates that the HBA supports Port Multiplier FIS-based switching. When cleared to '0', indicates that the HBA does not support FIS-based switching. AHCI 1.0 and 1.1 HBAs shall have this bit cleared to '0'.										
Supports Port Multiplier (SPM)	17	1b	Indicates whether the HBA can support a Port Multiplier. When set, a Port Multiplier using command-based switching is supported. When cleared to '0', a Port Multiplier is not supported, and a Port Multiplier may not be attached to this HBA.										
Supports AHCI mode only (SAM)	18	0b	The SATA controller may optionally support AHCI access mechanisms only. A value of '0' indicates that in addition to the native AHCI mechanism (via ABAR), the SATA controller implements a legacy, task-file based register interface such as SFF-8038i. A value of '1' indicates that the SATA controller does not implement a legacy, task-file based register interface.										
Supports Non-Zero DMA Offsets (SNZO)	19	0b	When set to '1', indicates that the HBA can support non-zero DMA offsets for DMA Setup FISes. This bit is reserved for future AHCI enhancements. AHCI 1.0 and 1.1 HBAs shall have this bit cleared to '0'.										
Interface Speed Support (ISS)	23:20	2h	Indicates the maximum speed the HBA can support on its ports. These encodings match the system software programmable PxSCTL.DET.SPD field. Values are: <table border="1" data-bbox="797 1507 1370 1759"> <thead> <tr> <th>Bits</th> <th>Definition</th> </tr> </thead> <tbody> <tr> <td>0000</td> <td>Reserved</td> </tr> <tr> <td>0001</td> <td>Gen 1 (1.5 Gbps)</td> </tr> <tr> <td>0010</td> <td>Gen 1 (1.5 Gbps) and Gen 2 (3 Gbps)</td> </tr> <tr> <td>0011 - 1111</td> <td>Reserved</td> </tr> </tbody> </table>	Bits	Definition	0000	Reserved	0001	Gen 1 (1.5 Gbps)	0010	Gen 1 (1.5 Gbps) and Gen 2 (3 Gbps)	0011 - 1111	Reserved
Bits	Definition												
0000	Reserved												
0001	Gen 1 (1.5 Gbps)												
0010	Gen 1 (1.5 Gbps) and Gen 2 (3 Gbps)												
0011 - 1111	Reserved												
Supports Command List Override (SCLO)	24	1b	When set to '1', the HBA supports the PxCMD.CLO bit and its associated function. When cleared to '0', the HBA is not capable of clearing the BSY and DRQ bits in the Status register in order to issue a software reset if these bits are still set from a previous operation.										

HBA Capabilities – R - 32bits [Mem_reg: ABAR + 00h]			
Field Name	Bits	Default	Description
Supports Activity LED (SAL)	25	1b	When set to '1', the HBA supports a single activity indication output pin. This pin can be connected to an LED on the platform to indicate device activity on any drive. When cleared to '0', this function is not supported.
Supports Aggressive Link Power Management (SALP)	26	1b	When set to '1', the HBA can support auto-generating link requests to the Partial or Slumber states when there are no commands to process. When cleared to '0', this function is not supported and software shall treat the PxCMD.ALPE and PxCMD.ASP bits as reserved.
Supports Staggered Spin-up (SSS)	27	0b	When set to '1', the HBA supports staggered spin-up on its ports, for use in balancing power spikes. When cleared to '0', this function is not supported. This value is loaded by the BIOS prior to OS initialization.
Supports Mechanical Presence Switch (SMPS)	28	1b	When set to '1', the HBA supports mechanical presence switches on its ports for use in hot plug operations. When cleared to '0', this function is not supported. This value is loaded by the BIOS prior to OS initialization.
Supports SNotification Register (SSNTF)	29	1b	When set to '1', the HBA supports the PxSNTF (SNotification) register and its associated functionality. When cleared to '0', the HBA does not support the PxSNTF (SNotification) register and its associated functionality.
Supports Native Command Queuing (SNCQ)	30	1b	Indicates whether the HBA supports Serial ATA native command queuing. If set to '1', an HBA shall handle DMA Setup FISes natively, and shall handle the auto-activate optimization through that FIS. If cleared to '0', native command queuing is not supported and software should not issue any native command queuing commands.
Supports 64-bit Addressing (S64A)	31	1b	Indicates whether the HBA can access 64-bit data structures. When set to '1', the HBA shall make the 32-bit upper bits of the port DMA Descriptor, the PRD Base, and each PRD entry read/write. When cleared to '0', these are read-only and treated as '0' by the HBA.

2.1.3.4 Offset 04h: GHC – Global HBA Control

This register controls the various global actions of the HBA.

Global HBA Control – RW - 32bits [Mem_reg: ABAR + 04h]			
Field Name	Bits	Default	Description
HBA Reset (HR)	0	0b	<p>When set by SW, this bit causes an internal reset of the HBA. All state machines that relate to data transfers and queuing shall return to an idle condition, and all ports shall be re-initialized via COMRESET (if staggered spin-up is not supported). If staggered spin-up is supported, then it is the responsibility of software to spin-up each port after the reset has completed.</p> <p>When the HBA has performed the reset action, it shall reset this bit to '0'. A software write of '0' shall have no effect. For a description on which bits are reset when this bit is set.</p>
Interrupt Enable (IE)	1	0b	<p>This global bit enables interrupts from the HBA. When cleared (reset default), all interrupt sources from all ports are disabled. When set, interrupts are enabled.</p>
MSI Revert to Single Message (MRSM)	2	0b	<p>When set to '1' by hardware, indicates that the HBA requested more than one MSI vector but has reverted to using the first vector only. When this bit is cleared to '0', the HBA has not reverted to single MSI mode (i.e. hardware is already in single MSI mode, software has allocated the number of messages requested, or hardware is sharing interrupt vectors if MC.MME < MC.MMC).</p> <p>The HBA may revert to single MSI mode when the number of vectors allocated by the host is less than the number requested. This bit shall only be set to '1' when the following conditions hold:</p> <ul style="list-style-type: none"> • MC.MSIE = '1' (MSI is enabled) • MC.MMC > 0 (multiple messages requested) • MC.MME > 0 (more than one message allocated) • MC.MME != MC.MMC (messages allocated not equal to number requested) <p>When this bit is set to '1', single MSI mode operation is in use and software is responsible for clearing bits in the IS register to clear interrupts.</p> <p>This bit shall be cleared to '0' by hardware when any of the four conditions stated is false. This bit is also cleared to '0' when MC.MSIE = '1' and MC.MME = 0h. In this case, the hardware has been programmed to use single MSI mode, and is not "reverting" to that mode. Read Only</p>
Reserved	30:3	000_0000h	Reserved.

Global HBA Control – RW - 32bits [Mem_reg: ABAR + 04h]			
Field Name	Bits	Default	Description
AHCI Enable (AE)	31	0b	<p>When set, indicates that communication to the HBA shall be via AHCI mechanisms. This can be used by an HBA that supports both legacy mechanisms (such as SFF-8038i) and AHCI to know when the HBA is running under an AHCI driver.</p> <p>When set, software shall only communicate with the HBA using AHCI. When cleared, software shall only communicate with the HBA using legacy mechanisms. When cleared FISes are not posted to memory and no commands are sent via AHCI mechanisms.</p> <p>Software shall set this bit to '1' before accessing other AHCI registers.</p>

2.1.3.5 Offset 08h: IS – Interrupt Status Register

This register indicates which of the ports within the controller have an interrupt pending and require service.

Interrupt Status - RW -32 bits [Mem_reg: ABAR + 08h]			
Field Name	Bits	Default	Description
Interrupt Pending Status (IPS)	31:0	0000_0000h	<p>If set, indicates that the corresponding port has an interrupt pending. Software can use this information to determine which ports require service after an interrupt.</p> <p>The IPS[x] bit is only defined for ports that are implemented or for the command completion coalescing interrupt defined by CCC_CTL.INT. All other bits are reserved. Write 1 clear these bits.</p>

2.1.3.6 Offset 0Ch: PI – Ports Implemented

This register indicates which ports are exposed by the HBA. It is loaded by the BIOS. It indicates which ports that the HBA supports are available for software to use. For example, on an HBA that supports 6 ports as indicated in CAP.NP, only ports 1 and 3 could be available, with ports 0, 2, 4, and 5 being unavailable. Software must not read or write to registers within unavailable ports. The intent of this register is to allow system vendors to build platforms that support less than the full number of ports implemented on the HBA silicon.

Ports Implemented Register - R -32 bits [Mem_reg: ABAR + 0Ch]			
Field Name	Bits	Default	Description
Port Implemented (PI)	31:0	0000_000Fh	<p>This register is bit significant. If a bit is set to '1', the corresponding port is available for software to use. If a bit is cleared to '0', the port is not available for software to use. The maximum number of bits set to '1' shall not exceed CAP.NP + 1, although the number of bits set in this register may be fewer than CAP.NP + 1. At least one bit shall be set to '1'.</p>

2.1.3.7 Offset 10h: VS – AHCI Version

This register indicates the major and minor version of the AHCI specification that the HBA implementation supports. The upper two bytes represent the major version number, and the lower two bytes represent the minor version number. Example: Version 3.12 would be represented as 00030102h. Three versions of the specification are valid: 0.95, 1.0, and 1.1.

AHCI Version- R – 32 bits [Mem_reg: ABAR + 10h]			
Field Name	Bits	Default	Description
Minor Version Number (MNR)	15:0	0100h	Indicates the minor version is “10”.
Major Version Number (MJR)	31:16	0001h	Indicates the major version is “1”

2.1.3.8 Offset 14h: CCC_CTL – Command Completion Coalescing Control

The command completion coalescing control register is used to configure the command completion coalescing feature for the entire HBA.

Implementation Note: HBA state variables (examples include hCccComplete and hCccTimer) are used to describe the required externally visible behavior. Implementations are not required to have internal state values that directly correspond to these variables.

Command Completion Coalescing Control(CCC_CTL) - RW – 32bits [Mem_reg: ABAR + 14h]			
Field Name	Bits	Default	Description
CCC_CTL Enable	0	0b	When cleared to '0', the command completion coalescing feature is disabled and no CCC interrupts are generated. When set to '1', the command completion coalescing feature is enabled and CCC interrupts may be generated based on timeout or command completion conditions. Software shall only change the contents of the TV and CC fields when EN is cleared to '0'. On transition of this bit from '0' to '1', any updated values for the TV and CC fields shall take effect.
Reserved	2:1	0h	Reserved
CCC Interrupt (INT)	7:3	1Fh	Read Only Specifies the interrupt used by the CCC feature. This interrupt must be marked as unused in the Ports Implemented (PI) register by the corresponding bit being set to '0'. Thus, the CCC interrupt corresponds to the interrupt for an unimplemented port on the controller. When a CCC interrupt occurs, the IS.IPS[INT] bit shall be asserted to '1'. This field also specifies the interrupt vector used for MSI.
Command Completions (CC)	15:8	01h	Specifies the number of command completions that are necessary to cause a CCC interrupt. The HBA has an internal command completion counter, hCccComplete. hCccComplete is incremented by one each time a selected port has a command completion. When hCccComplete is equal to the command completions value, a CCC interrupt is signaled. The internal command completion counter is reset to '0' on the assertion of each CCC interrupt. A value of '0' for this field shall disable CCC interrupts being generated based on the number of commands completed, i.e. CCC interrupts are only generated based on the timer in this case.

Command Completion Coalescing Control(CCC_CTL) - RW – 32bits [Mem_reg: ABAR + 14h]			
Field Name	Bits	Default	Description
Timeout Value (TV)	31:16	0001h	The timeout value is specified in 1 millisecond intervals. The timer accuracy shall be within 5%. hCccTimer is loaded with this timeout value. hCccTimer is only decremented when commands are outstanding on selected ports. The HBA will signal a CCC interrupt when hCccTimer has decremented to '0'. hCccTimer is reset to the timeout value on the assertion of each CCC interrupt. A timeout value of '0' is reserved.

2.1.3.9 Offset 18h: CCC_PORTS – Command Completion Coalescing Ports

The command completion coalescing ports register is used to specify the ports that are coalesced as part of the CCC feature when CCC_CTL.EN = '1'.

Command Completion Coalescing Ports - RW – 32bits [Mem_reg: ABAR + 18h]			
Field Name	Bits	Default	Description
Ports (PRT)	31:0	0000_0000h	This register is bit significant. Each bit corresponds to a particular port, where bit 0 corresponds to port 0. If a bit is set to '1', the corresponding port is part of the command completion coalescing feature. If a bit is cleared to '0', the port is not part of the command completion coalescing feature. Bits set to '1' in this register must also have the corresponding bit set to '1' in the Ports Implemented register. An updated value for this field shall take effect within one timer increment (1 millisecond).

Note: Registers at offset A0h to FFh are vendor specific.

2.1.3.10 Port Registers (one set per port)

The following registers describe the registers necessary to implement port 0. Additional ports shall have the same register mapping. Port 1 starts at 180h, port 2 starts at 200h, port 3 at 280h, etc. The algorithm for software to determine the offset is as follows:

- Port offset = 100h + (PI Asserted Bit Position * 80h)

Register Name	Offset Address
Port-N Command List Base Address(PNCLB)	00h-03h + Port offset
Port-N Command List Base Address Upper 32-Bits(PNCLBU)	04h-07h + Port offset
Port-N FIS Base Address(PNFB)	08h-0Bh + Port offset
Port-N FIS Base Address Upper 32-Bits(PNFBU)	0Ch-0Fh + Port offset
Port-N Interrupt Status(PNIS)	10h-13h + Port offset
Port-N Interrupt Enable(PNIE)	14h-17h + Port offset
Port-N Command and Status(PNCMD)	18h-1Bh + Port offset
Reserved	1Ch-1Fh + Port offset
Port-N Task File Data(PNTFD)	20h-23h + Port offset
Port-N Signature(PNSIG)	24h-27h + Port offset
Port-N Serial ATA Status (PNSSTS)	28h-2Bh + Port offset
Port-N Serial ATA Control (PNSCTL)	2Ch-2Fh + Port offset
Port-N Serial ATA Error (PNSERR)	30h-33h + Port offset
Port-N Serial ATA Active (PNSACT)	34h-37h + Port offset
Port-N Command Issue(PNCI)	38h-3Bh + Port offset
Port-N SNotification (PNSNTF)	3Ch-3Fh + Port offset
Reserved for FIS-based Switching Definition	40h-43h + Port offset
Reserved	44h-6Fh + Port offset
Port-N Vendor Specific(PNVS)	70h-7Fh + Port offset

*N is the port number, 0 ~ 5

Port-N Command List Base Address -RW -32 bits [Mem_reg: ABAR + port offset + 00h]			
Field Name	Bits	Default	Description
Reserved	9:0	000h	Reserved.
Command List Base Address (CLB)	31:10	00_0000h	Indicates the 32-bit base physical address for the command list for this port. This base is used when fetching commands to execute. The structure pointed to by this address range is 1K-bytes in length. This address must be 1K-byte aligned as indicated by bits 09:00 being read only.

Port-N Command List Base Upper Address -RW - 32 bits [Mem_reg: ABAR + port offset + 04h]			
Field Name	Bits	Default	Description
Command List Base Address Upper (CLBU)	31:0	0000_0000h	Indicates the upper 32-bits for the command list base physical address for this port. This base is used when fetching commands to execute. This register shall be read only '0' for HBAs that do not support 64-bit addressing.

Port-N FIS Base Address -RW -32 bits [Mem_reg: ABAR + port offset + 08h]			
Field Name	Bits	Default	Description
Reserved	7:0	00h	Reserved.
FIS Base Address (FB):	31:8	00_0000h	Indicates the 32-bit base physical address for received FISes. The structure pointed to by this address range is 256 bytes in length. This address must be 256-byte aligned as indicated by bits 07:00 being read only.

Port-N FIS Base Address Upper -RW - 32 bits [Mem_reg: ABAR + port offset + 0Ch]			
Field Name	Bits	Default	Description
FIS Base Address Upper (FBU)	31:0	0000_0000h	Indicates the upper 32-bits for the received FIS base physical address for this port. This register shall be read only '0' for HBAs that do not support 64-bit addressing.

Port-N Interrupt Status - RW - 32 bits [Mem_reg: ABAR + port offset + 10h]			
Field Name	Bits	Default	Description
Device to Host Register FIS Interrupt (DHRS)	0	0b	A D2H Register FIS has been received with the '1' bit set, and has been copied into system memory.
PIO Setup FIS Interrupt (PSS)	1	0b	A PIO Setup FIS has been received with the '1' bit set, it has been copied into system memory, and the data related to that FIS has been transferred. This bit shall be set even if the data transfer resulted in an error.
DMA Setup FIS Interrupt (DSS)	2	0b	A DMA Setup FIS has been received with the '1' bit set and has been copied into system memory.
Set Device Bits Interrupt (SDBS)	3	0b	A Set Device Bits FIS has been received with the '1' bit set and has been copied into system memory.

Port-N Interrupt Status - RW - 32 bits [Mem_reg: ABAR + port offset + 10h]			
Field Name	Bits	Default	Description
Unknown FIS Interrupt (UFS)	4	0b	Read Only When set to '1', indicates that an unknown FIS was received and has been copied into system memory. This bit is cleared to '0' by software clearing the PxSERR.DIAG.F bit to '0'. Note that this bit does not directly reflect the PxSERR.DIAG.F bit. PxSERR.DIAG.F is set immediately when an unknown FIS is detected, whereas this bit is set when that FIS is posted to memory. Software should wait to act on an unknown FIS until this bit is set to '1' or the two bits may become out of sync.
Descriptor Processed (DPS)	5	0b	A PRD with the '1' bit set has transferred all of its data.
Port Connect Change Status (PCS)	6	0b	Read Only 1=Change in <i>Current Connect Status</i> . 0=No change in <i>Current Connect Status</i> . This bit reflects the state of PxSERR.DIAG.X. This bit is only cleared when PxSERR.DIAG.X is cleared.
Device Mechanical Presence Status (DMPS)	7	0b	When set, indicates that a mechanical presence switch attached to this port has been opened or closed, which may lead to a change in the connection state of the device. This bit is only valid if both CAP.SMPS and POCMD.MPSP are set to '1'.
Reserved	21:8	0000h	Reserved
PhyRdy Change Status (PRCS)	22	0b	Read Only When set to '1' indicates the internal PhyRdy signal changed state. This bit reflects the state of P0SERR.DIAG.N. To clear this bit, software must clear P0SERR.DIAG.N to '0'.
Incorrect Port Multiplier Status (IPMS):	23	0b	Indicates that the HBA received a FIS from a device whose Port Multiplier field did not match what was expected. The IPMS bit may be set during enumeration of devices on a Port Multiplier due to the normal Port Multiplier enumeration process. It is recommended that IPMS only be used after enumeration is complete on the Port Multiplier.
Overflow Status (OFS)	24	0b	Indicates that the HBA received more bytes from a device than was specified in the PRD table for the command.
Reserved	25	0b	Reserved
Interface Non-fatal Error Status (INFS)	26	0b	Indicates that the HBA encountered an error on the Serial ATA interface but was able to continue operation.
Interface Fatal Error Status (IFS)	27	0b	Indicates that the HBA encountered an error on the Serial ATA interface which caused the transfer to stop.
Host Bus Data Error Status (HBDS)	28	0b	Indicates that the HBA encountered a data error (uncorrectable ECC / parity) when reading from or writing to system memory.
Host Bus Fatal Error Status (HBFS)	29	0b	Indicates that the HBA encountered a host bus error that it cannot recover from, such as a bad software pointer. In PCI, such an indication would be a target or master abort.
Task File Error Status (TFES):	30	0b	This bit is set whenever the status register is updated by the device and the error bit (bit 0) is set.
Cold Port Detect Status (CPDS)	31	0b	When set, a device status has changed as detected by the cold presence detect logic. This bit can either be set due to a non-connected port receiving a device, or a connected port having its device removed. This bit is only valid if the port supports cold presence detect as indicated by PxCMD.CPD set to '1'.
Write 1 clear these status bits			

Port-N Interrupt Enable - RW -32 bits [Mem_reg: ABAR + port offset + 14h]			
Field Name	Bits	Default	Description
Device to Host Register FIS Interrupt Enable (DHRE)	0	0b	When set, GHC.IE is set, and P0IS.DHRS is set, the HBA shall generate an interrupt.
PIO Setup FIS Interrupt Enable (PSE)	1	0b	When set, GHC.IE is set, and P0IS.PSS is set, the HBA shall generate an interrupt.
DMA Setup FIS Interrupt Enable (DSE)	2	0b	When set, GHC.IE is set, and P0IS.DSS is set, the HBA shall generate an interrupt.
Set Device Bits FIS Interrupt Enable (SDBE)	3	0b	When set, GHC.IE is set, and P0IS.SDBS is set, the HBA shall generate an interrupt.
Unknown FIS Interrupt Enable (UFE)	4	0b	When set, GHC.IE is set, and P0IS.UFS is set to '1', the HBA shall generate an interrupt.
Descriptor Processed Interrupt Enable (DPE)	5	0b	When set, GHC.IE is set, and P0IS.DPS is set, the HBA shall generate an interrupt.
Port Change Interrupt Enable (PCE)	6	0b	When set, GHC.IE is set, and P0IS.PCS is set, the HBA shall generate an interrupt.
Device Mechanical Presence Enable (DMPE)	7	0b	When set, and GHC.IE is set to '1', and P0IS.DMPS is set, the HBA shall generate an interrupt. For systems that do not support a mechanical presence switch, this bit shall be a read-only '0'.
Reserved	21:8	0000h	Reserved
PhyRdy Change Interrupt Enable (PRCE)	22	0b	When set to '1', and GHC.IE is set to '1', and P0IS.PRCS is set to '1', the HBA shall generate an interrupt.
Incorrect Port Multiplier Enable (IPME)	23	0b	When set, and GHC.IE and P0IS.IPMS are set, the HBA shall generate an interrupt.
Overflow Enable (OFE)	24	0b	When set, and GHC.IE and P0IS.OFS are set, the HBA shall generate an interrupt.
Reserved	25	0b	Reserved
Interface Non-fatal Error Enable (INFE)	26	0b	When set, GHC.IE is set, and P0IS.INFS is set, the HBA shall generate an interrupt.
Interface Fatal Error Enable (IFE)	27	0b	When set, GHC.IE is set, and P0IS.IFS is set, the HBA shall generate an interrupt..
Host Bus Data Error Enable (HBDE)	28	0b	when set, GHC.IE is set, and P0IS.HBDS is set, the HBA shall generate an interrupt..
Host Bus Fatal Error Enable (HBFE)	29	0b	When set, GHC.IE is set, and P0IS.HBFS is set, the HBA shall generate an interrupt.
Task File Error Enable (TFEE)	30	0b	When set, GHC.IE is set, and P0S.TFES is set, the HBA shall generate an interrupt.
Cold Presence Detect Enable (CPDE)	31	0b	When set, GHC.IE is set, and P0S.CPDS is set, the HBA shall generate an interrupt. For systems that do not support cold presence detect, this bit shall be a read-only '0'.

Port-N Command and Status - R - 32 bits [Mem_reg: ABAR + port offset + 18h]			
Field Name	Bits	Default	Description
Start (ST)	0	0b	RW When set, the HBA may process the command list. When cleared, the HBA may not process the command list. Whenever this bit is changed from a '0' to a '1', the HBA starts processing the command list at entry '0'. Whenever this bit is changed from a '1' to a '0', the PxCI register is cleared by the HBA upon the HBA putting the controller into an idle state. This bit shall only be set to '1' by software after PxCMD.FRE has been set to '1'.

Port-N Command and Status - R - 32 bits [Mem_reg: ABAR + port offset + 18h]			
Field Name	Bits	Default	Description
Spin-Up Device (SUD)	1	1b	This bit is read/write for HBAs that support staggered spin-up via CAP.SSS. This bit is read only '1' for HBAs that do not support staggered spin-up. On an edge detect from '0' to '1', the HBA shall start a COMRESET initialization sequence to the device. Clearing this bit to '0' does not cause any OOB signal to be sent on the interface. When this bit is cleared to '0' and PxSCTL.DET=0h, the HBA will enter listen mode.
Power On Device (POD)	2	1b	This bit is read/write for HBAs that support cold presence detection on this port as indicated by PxCMD.CPD set to '1'. This bit is read only '1' for HBAs that do not support cold presence detect. When set, the HBA sets the state of a pin on the HBA to '1' so that it may be used to provide power to a cold-presence detectable port.
Command List Override (CLO)	3	0b	RW Setting this bit to '1' causes PxTFD.STS.BSY and PxTFD.STS.DRQ to be cleared to '0'. This allows a software reset to be transmitted to the device regardless of whether the BSY and DRQ bits are still set in the PxTFD.STS register. The HBA sets this bit to '0' when PxTFD.STS.BSY and PxTFD.STS.DRQ have been cleared to '0'. A write to this register with a value of '0' shall have no effect. This bit shall only be set to '1' immediately prior to setting the PxCMD.ST bit to '1' from a previous value of '0'. Setting this bit to '1' at any other time is not supported and will result in indeterminate behavior. Software must wait for CLO to be cleared to '0' before setting PxCMD.ST to '1'.
FIS Receive Enable (FRE)	4	0b	When set, the HBA may post received FISes into the FIS receive area pointed to by PxFB (and for 64-bit HBAs, PxFB). When cleared, received FISes are not accepted by the HBA, except for the first D2H register FIS after the initialization sequence, and no FISes are posted to the FIS receive area. System software must not set this bit until PxFB (PxFB) have been programmed with a valid pointer to the FIS receive area, and if software wishes to move the base, this bit must first be cleared, and software must wait for the FR bit in this register to be cleared
Reserved	7:5	0h	Reserved
Current Command Slot (CCS)	12:8	00h	This field is valid when POCMD.ST is set to '1' and shall be set to the command slot value of the command that is currently being issued by the HBA. When POCMD.ST transitions from '1' to '0', this field shall be reset to '0'. After POCMD.ST transitions from '0' to '1', the highest priority slot to issue from next is command slot 0. After the first command has been issued, the highest priority slot to issue from next is POCMD.CCS + 1. For example, after the HBA has issued its first command, if CCS = 0h and POCI is set to 3h, the next command that will be issued is from command slot 1.
Mechanical Presence Switch State (MPSS)	13	1b	The MPSS bit reports the state of a mechanical presence switch attached to this port. If CAP.SMPS is set to '1' and the mechanical presence switch is closed then this bit is cleared to '0'. If CAP.SMPS is set to '1' and the mechanical presence switch is open then this bit is set to '1'. If CAP.SMPS is set to '0' then this bit is cleared to '0'. Software should only use this bit if both CAP.SMPS and POCMD.MPSP are set to '1'.

Port-N Command and Status - R - 32 bits [Mem_reg: ABAR + port offset + 18h]			
Field Name	Bits	Default	Description
FIS Receive Running (FR):	14	0b	When set, the FIS Receive DMA engine for the port is running.
Command List Running (CR)	15	0b	When this bit is set, the command list DMA engine for the port is running. See the AHCI state machine in section.
Cold Presence State (CPS)	16	0b	The CPS bit reports whether a device is currently detected on this port via cold presence detection. If CPS is set to '1', then the HBA detects via cold presence that a device is attached to this port. If CPS is cleared to '0', then the HBA detects via cold presence that there is no device attached to this port.
Port Multiplier Attached (PMA)	17	0b	This bit is read/write for HBAs that support a Port Multiplier (CAP.SPM = '1'). This bit is read-only for HBAs that do not support a port Multiplier (CAP.SPM = '0'). When set to '1' by software, a Port Multiplier is attached to the HBA for this port. When cleared to '0' by software, a Port Multiplier is not attached to the HBA for this port. Software is responsible for detecting whether a Port Multiplier is present; hardware does not auto-detect the presence of a Port Multiplier.
Hot Plug Capable Port (HPCP)	18	1b	When set to '1', indicates that this port's signal and power connectors are externally accessible via a joint signal and power connector for blindmate device hot plug. When cleared to '0', indicates that this port's signal and power connectors are not externally accessible via a joint signal and power connector.
Mechanical Presence Switch Attached to Port (MPSP)	19	0b	If set to '1', the platform supports a mechanical presence switch attached to this port. If cleared to '0', the platform does not support a mechanical presence switch attached to this port. When this bit is set to '1', POCMD.HPCP should also be set to '1'.
Cold Presence Detection (CPD)	20	0b	If set to '1', the platform supports cold presence detection on this port. If cleared to '0', the platform does not support cold presence detection on this port. When this bit is set to '1', POCMD.HPCP should also be set to '1'.
External SATA Port (ESP)	21	0b	When set to '1', indicates that this port's signal connector is externally accessible on a signal only connector. When set to '1', CAP.SXS shall be set to '1'. When cleared to '0', indicates that this port's signal connector is not externally accessible on a signal only connector. ESP is mutually exclusive with the HPCP bit in this register.
Reserved	23:22	0h	Reserved
Device is ATAPI (ATAPI)	24	0b	RW When set to '1', the connected device is an ATAPI device. This bit is used by the HBA to control whether or not to generate the desktop LED when commands are active.
Drive LED on ATAPI Enable (DLAE)	25	0b	RW When set to '1', the HBA shall drive the LED pin active for commands regardless of the state of POCMD.ATAPI. When cleared, the HBA shall only drive the LED pin active for commands if POCMD.ATAPI set to '0'.
Aggressive Link Power Management Enable (ALPE)	26	0b	RW When set to '1', the HBA shall aggressively enter a lower link power state (Partial or Slumber) based upon the setting of the ASP bit. Software shall only set this bit to '1' if CAP.SALP is set to '1'; if CAP.SALP is cleared to '0' software shall treat this bit as reserved.

Port-N Command and Status - R - 32 bits [Mem_reg: ABAR + port offset + 18h]																	
Field Name	Bits	Default	Description														
Aggressive Slumber / Partial (ASP)	27	0b	RW When set to '1', and ALPE is set, the HBA shall aggressively enter the Slumber state when it clears the PxCI register and the PxSACT register is cleared or when it clears the PxSACT register and PxCI is cleared. When cleared, and ALPE is set, the HBA shall aggressively enter the Partial state when it clears the PxCI register and the PxSACT register is cleared or when it clears the PxSACT register and PxCI is cleared. If CAP.SALP is cleared to '0' software shall treat this bit as reserved.														
Interface Communication Control (ICC)	31:28	0h	RW This field is used to control power management states of the interface. If the Link layer is currently in the L_IDLE state, writes to this field shall cause the HBA to initiate a transition to the interface power management state requested. If the Link layer is not currently in the L_IDLE state, writes to this field shall have no effect. <table border="1" data-bbox="781 743 1386 1440"> <thead> <tr> <th>Value</th> <th>Definition</th> </tr> </thead> <tbody> <tr> <td><i>Fh – 7h</i></td> <td><i>Reserved</i></td> </tr> <tr> <td>6h</td> <td>Slumber: This shall cause the HBA to request a transition of the interface to the Slumber state. The SATA device may reject the request and the interface shall remain in its current state.</td> </tr> <tr> <td><i>5h – 3h</i></td> <td><i>Reserved</i></td> </tr> <tr> <td>2h</td> <td>Partial: This shall cause the HBA to request a transition of the interface to the Partial state. The SATA device may reject the request and the interface shall remain in its current state.</td> </tr> <tr> <td>1h</td> <td>Active: This shall cause the HBA to request a transition of the interface into the active state.</td> </tr> <tr> <td>0h</td> <td>No-Op / Idle: When software reads this value, it indicates the HBA is ready to accept a new interface control command, although the transition to the previously selected state may not yet have occurred.</td> </tr> </tbody> </table> <p>When system software writes a non-reserved value other than No-Op (0h), the HBA shall perform the action and update this field back to Idle (0h).</p> <p>If software writes to this field to change the state to a state the link is already in (i.e. interface is in the active state and a request is made to go to the active state), the HBA shall take no action and return this field to Idle. If the interface is in a low power state and software wants to transition to a different low power state, software must first bring the link to active and then initiate the transition to the desired low power state.</p>	Value	Definition	<i>Fh – 7h</i>	<i>Reserved</i>	6h	Slumber: This shall cause the HBA to request a transition of the interface to the Slumber state. The SATA device may reject the request and the interface shall remain in its current state.	<i>5h – 3h</i>	<i>Reserved</i>	2h	Partial: This shall cause the HBA to request a transition of the interface to the Partial state. The SATA device may reject the request and the interface shall remain in its current state.	1h	Active: This shall cause the HBA to request a transition of the interface into the active state.	0h	No-Op / Idle: When software reads this value, it indicates the HBA is ready to accept a new interface control command, although the transition to the previously selected state may not yet have occurred.
Value	Definition																
<i>Fh – 7h</i>	<i>Reserved</i>																
6h	Slumber: This shall cause the HBA to request a transition of the interface to the Slumber state. The SATA device may reject the request and the interface shall remain in its current state.																
<i>5h – 3h</i>	<i>Reserved</i>																
2h	Partial: This shall cause the HBA to request a transition of the interface to the Partial state. The SATA device may reject the request and the interface shall remain in its current state.																
1h	Active: This shall cause the HBA to request a transition of the interface into the active state.																
0h	No-Op / Idle: When software reads this value, it indicates the HBA is ready to accept a new interface control command, although the transition to the previously selected state may not yet have occurred.																

Port-N Task Fike Data – R – 32 bits [Mem_reg: ABAR + port offset + 20h]																					
Field Name	Bits	Default	Description																		
Status (STS)	7:0	7Fh	Contains the latest copy of the task file status register. Fields of note in this register that affect AHCI hardware operation are: <table border="1" data-bbox="776 401 1393 667"> <thead> <tr> <th>Bits</th> <th>Field</th> <th>Definition</th> </tr> </thead> <tbody> <tr> <td>7</td> <td>BSY</td> <td>Indicates the interface is busy</td> </tr> <tr> <td>6:4</td> <td>cs</td> <td>Command specific</td> </tr> <tr> <td>3</td> <td>DRQ</td> <td>Indicates a data transfer is requested</td> </tr> <tr> <td>2:1</td> <td>cs</td> <td>Command specific</td> </tr> <tr> <td>0</td> <td>ERR</td> <td>Indicates an error during the transfer.</td> </tr> </tbody> </table>	Bits	Field	Definition	7	BSY	Indicates the interface is busy	6:4	cs	Command specific	3	DRQ	Indicates a data transfer is requested	2:1	cs	Command specific	0	ERR	Indicates an error during the transfer.
Bits	Field	Definition																			
7	BSY	Indicates the interface is busy																			
6:4	cs	Command specific																			
3	DRQ	Indicates a data transfer is requested																			
2:1	cs	Command specific																			
0	ERR	Indicates an error during the transfer.																			
ERROR	15:8	00h	Contains the latest copy of the task file error register.																		
Reserved	31:16	0000h	Reserved																		

Port-N Signature – R – 32 bits [Mem_reg: ABAR + port offset + 24h]													
Field Name	Bits	Default	Description										
Signature (SIG)	31:0	FFFF_FFFF h	Contains the signature received from a device on the first D2H Register FIS. The bit order is as follows: <table border="1" data-bbox="846 917 1321 1136"> <thead> <tr> <th>Bits</th> <th>Field</th> </tr> </thead> <tbody> <tr> <td>31:24</td> <td>LBA High Register</td> </tr> <tr> <td>23:16</td> <td>LBA Mid Register</td> </tr> <tr> <td>15:08</td> <td>LBA Low Register</td> </tr> <tr> <td>07:00</td> <td>Sector Count Register</td> </tr> </tbody> </table>	Bits	Field	31:24	LBA High Register	23:16	LBA Mid Register	15:08	LBA Low Register	07:00	Sector Count Register
Bits	Field												
31:24	LBA High Register												
23:16	LBA Mid Register												
15:08	LBA Low Register												
07:00	Sector Count Register												

Note: It is updated once after a reset sequence

Port-N Serial ATA Status – R – 32 bits [Mem_reg: ABAR + port offset + 28h]			
Field Name	Bits	Default	Description
Device Detection (DET)	3:0	0h	Indicates the interface device detection and Phy state. <ul style="list-style-type: none"> 0h No device detected and Phy communication not established 1h Device presence detected but Phy communication not established 3h Device presence detected and Phy communication established 4h Phy in offline mode as a result of the interface being disabled or running in a BIST loopback mode All other values reserved. Read Only
Current Interface Speed (SPD)	7:4	0h	Indicates the negotiated interface communication speed. <ul style="list-style-type: none"> 0h Device not present or communication not established 1h Generation 1 communication rate negotiated 2h Generation 2 communication rate negotiated All other values reserved. Read Only

Port-N Serial ATA Status – R – 32 bits [Mem_reg: ABAR + port offset + 28h]			
Field Name	Bits	Default	Description
Interface Power Management (IPM)	11:8	0h	Indicates the current interface state: 0h Device not present or communication not established 1h Interface in active state 2h Interface in Partial power management state 6h Interface in Slumber power management state All other values reserved. Read Only
Reserved	31:12	0_0000h	Reserved

Port-N Serial ATA Control – RW – 32 bits [Mem_reg: ABAR + port offset + 2Ch]			
Field Name	Bits	Default	Description
Device Detection Initialization (DET)	3:0	0h	Controls the HBA's device detection and interface initialization. 0h No device detection or initialization action requested 1h Perform interface communication initialization sequence to establish communication. This is functionally equivalent to a hard reset and results in the interface being reset and communications reinitialized. While this field is 1h, COMRESET is transmitted on the interface. Software should leave the DET field set to 1h for a minimum of 1 millisecond to ensure that a COMRESET is sent on the interface. 4h Disable the Serial ATA interface and put Phy in offline mode. All other values reserved This field may only be modified when P0CMD.ST is '0'. Changing this field while the P0CMD.ST bit is set to '1' results in undefined behavior. When P0CMD.ST is set to '1', this field should have a value of 0h. Note: It is permissible to implement any of the Serial ATA defined behaviors for transmission of COMRESET when DET=1h.
Speed Allowed (SPD)	7:4	0h	Indicates the highest allowable speed of the interface. 0h No speed negotiation restrictions 1h Limit speed negotiation to Generation 1 communication rate 2h Limit speed negotiation to a rate not greater than Generation 2 communication rate All other values reserved

Port-N Serial ATA Control – RW – 32 bits [Mem_reg: ABAR + port offset + 2Ch]			
Field Name	Bits	Default	Description
Interface Power Management Transitions Allowed (IPM)	11:8	0h	Indicates which power states the HBA is allowed to transition to. If an interface power management state is disabled, the HBA is not allowed to initiate that state and the HBA must PMNAK _P any request from the device to enter that state. 0h No interface restrictions 1h Transitions to the Partial state disabled 2h Transitions to the Slumber state disabled 3h Transitions to both Partial and Slumber states disabled All other values reserved
Select Power Management (SPM):	15:12	0h	This field is not used by AHCI. Read Only
Port Multiplier Port (PMP):	19:16	0h	This field is not used by AHCI. Read Only
Reserved	31:20	000h	Reserved

Port-N Serial ATA Error – RW – 32 bits [Mem_reg: ABAR + port offset + 30h]				
Field Name	Bits	Default	Description	
ERROR	15:0	0000h	The ERR field contains error information for use by host software in determining the appropriate response to the error condition. Write 1 clear.	
			Bit	Description
			15:12	Reserved
			11	Internal Error (E): The host bus adapter experienced an internal error that caused the operation to fail and may have put the host bus adapter into an error state. The internal error may include a master or target abort when attempting to access system memory, an elasticity buffer overflow, a primitive misalignment, a synchronization FIFO overflow, and other internal error conditions. Typically when an internal error occurs, a non-fatal or fatal status bit in the PxIS register will also be set to give software guidance on the recovery mechanism required.
			10	Protocol Error (P): A violation of the Serial ATA protocol was detected.
			9	Persistent Communication or Data Integrity Error (C): A communication error that was not recovered occurred that is expected to be persistent. Persistent communications errors may arise from faulty interconnect with the device, from a device that has been removed or has failed, or a number of other causes.
			8	Transient Data Integrity Error (T): A data integrity error occurred that was not recovered by the interface. This bit is set upon any error when a Data FIS is received, including reception FIFO overflow, CRC error or 10b8b decoding error.
			7:2	Reserved
			1	Recovered Communications Error (M): Communications between the device and host was temporarily lost but was re-established. This can arise from a device temporarily being removed, from a temporary loss of Phy synchronization, or from other causes and may be derived from the PhyNRdy signal between the Phy and Link layers.
			0	Recovered Data Integrity Error (I): A data integrity error occurred that was recovered by the interface through a retry operation or other recovery action. This bit is set upon any error when a Data FIS is received, including reception FIFO overflow, CRC error or 10b8b decoding error.

Port-N Serial ATA Error – RW – 32 bits [Mem_reg: ABAR + port offset + 30h]				
Field Name	Bits	Default	Description	
Diagnostics (DIAG)	31:16	0000h	Contains diagnostic error information for use by diagnostic software in validating correct operation or isolating failure modes:	
			Bits	Description
			31:27	<i>Reserved</i>
			26	Exchanged (X): When set to one this bit indicates a COMINIT signal was received. This bit is reflected in the POIS.PCS bit.
			25	Unknown FIS Type (F): Indicates that one or more FISs were received by the Transport layer with good CRC, but had a type field that was not recognized/known.
			24	Transport state transition error (T): Indicates that an error has occurred in the transition from one state to another within the Transport layer since the last time this bit was cleared. This bit is always 0 in current implementation.
			23	Link Sequence Error (S): Indicates that one or more Link state machine error conditions was encountered. The Link Layer state machine defines the conditions under which the link layer detects an erroneous transition. This bit is always 0 in current implementation.
			22	Handshake Error (H): Indicates that one or more R_ERR handshake response was received in response to frame transmission. Such errors may be the result of a CRC error detected by the recipient, a disparity or 8b/10b decoding error, or other error condition leading to a negative handshake on a transmitted frame.
			21	CRC Error (C): Indicates that one or more CRC errors occurred with the Link Layer.
			20	Disparity Error (D): <i>This field is not used by AHCI.</i> This bit is always 0 in current implementation.
			19	10B to 8B Decode Error (B): Indicates that one or more 10B to 8B decoding errors occurred.
			18	Comm Wake (W): Indicates that a Comm Wake signal was detected by the Phy.
			17	Phy Internal Error (I): Indicates that the Phy detected some internal error. This bit is always 0 in current implementation.
16	PhyRdy Change (N): Indicates that the PhyRdy signal changed state. This bit is reflected in the POIS.PRCS bit.			
			Write 1 clear.	

Port-N Serial ATA Active [Mem_reg: ABAR + port offset + 34h]			
Field Name	Bits	Default	Description
Device Status (DS)	31:0	0000_0000h	<p>This field is bit significant. Each bit corresponds to the TAG and command slot of a native queued command, where bit 0 corresponds to TAG 0 and command slot 0. This field is set by software prior to issuing a native queued command for a particular command slot. Prior to writing PxCi[TAG] to '1', software will set DS[TAG] to '1' to indicate that a command with that TAG is outstanding. The device clears bits in this field by sending a Set Device Bits FIS to the host. The HBA clears bits in this field that are set to '1' in the SActive field of the Set Device Bits FIS. The HBA only clears bits that correspond to native queued commands that have completed successfully.</p> <p>Software should only write this field when PxCMD.ST is set to '1'. This field is cleared when PxCMD.ST is written from a '1' to a '0' by software. This field is not cleared by a COMRESET or a software reset.</p>

Port-N Command Issue – RW – 32 bits [Mem_reg: ABAR + port offset + 38h]			
Field Name	Bits	Default	Description
Commands Issued (CI)	31:0	0000_0000h	<p>This field is bit significant. Each bit corresponds to a command slot, where bit 0 corresponds to command slot 0. This field is set by software to indicate to the HBA that a command has been built in system memory for a command slot and may be sent to the device. When the HBA receives a FIS which clears the BSY, DRQ, and ERR bits for the command, it clears the corresponding bit in this register for that command slot. Bits in this field shall only be set to '1' by software when PxCMD.ST is set to '1'.</p> <p>This field is also cleared when PxCMD.ST is written from a '1' to a '0' by software.</p>

Port- N SNotification – RWC – 32 bits [Mem_reg: ABAR + port offset + 3Ch]			
Field Name	Bits	Default	Description
PM Notify (PMN)	15:0	0000h	<p>This field indicates whether a particular device with the corresponding PM Port number issued a Set Device Bits FIS to the host with the Notification bit set.</p> <p style="text-align: center;">PM Port 0h sets bit [0] ...</p> <p style="text-align: center;">PM Port Fh sets bit [15]</p> <p>Individual bits are cleared by software writing 1's to the corresponding bit positions.</p> <p>This field is reset to default on a HBA Reset, but it is not reset by COMRESET or software reset.</p>
Reserved	31:16	0000h	Reserved

2.1.3.11 Mem_reg: ABAR + port offset + 40h: Reserved for FIS-Based Switching

These registers are reserved for the Port Multiplier FIS-based switching definition.

2.2 OHCI USB 1.1 and EHCI USB 2.0 Controllers (Bus 0, Device 18/19/20)

Each controller in USB is composed of PCI configuration and memory mapped registers. These registers are cleared by the PCI RST# signal; therefore they will be cleared on a warm boot.

Note: Some USB functions are controlled by, and associated with, certain PCI configuration registers in the SMBus/ACPI device. For more information refer to [section 2.4: SMBus Module and ACPI Block \(Device 20, Function 0\)](#). The diagram below lists these USB functions and the associated registers.

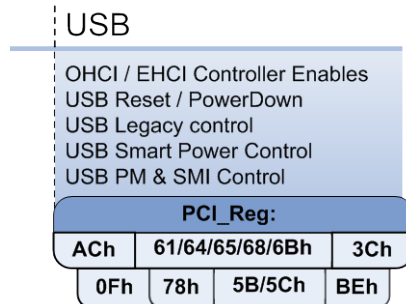

There are total 2 EHCI controllers and 5 OHCI controllers to form 3 individual PCI devices. The 3 individual PCI devices will be names USB controller#1, #2, and #3. Both USB controllers #1 (Device-18) and #2 (Device-19) includes 2 OHCI controllers (fun-0 & fun-1) and one EHCI controller (fun-2). USB controller #3 (Device-20, fun-5) only contains 1 OHCI controller.

Device / Function	Controller	Port #
USB Controller #1		
Device-18, fun-0	OHCI0	0 ~ 2
Device-18, fun-1	OHCI1	3 ~ 5
Device-18, fun-2	EHCI	0 ~ 5
USB Controller #2		
Device-19, fun-0	OHCI0	6 ~ 8
Device-19, fun-1	OHCI1	9 ~ 11
Device-19, fun-2	EHCI	6 ~ 11
USB Controller #3		
Device-20, fun-5	OHCI0	12 ~ 13

2.2.1 OHCI Registers (Device 18/19/20)

2.2.1.1 USB 1 & USB 2 (Device-18/19 function 0) OHCI0 – PCI Configuration Registers

Register Name	Offset Address
Device / Vendor ID	00h
Command	04h
Status	06h
Revision ID / Class Code	08h
Miscellaneous	0Ch
BAR_OHCI	10h
Subsystem Vendor ID / Subsystem ID	2Ch
Capability Pointer	34h
Interrupt Line	3Ch
Config Timers / MSI Disable	40h – 41h
Port Disable Control	42h
OHCI Misc Control	50h
Over Current Control 1	58h

Register Name	Offset Address
OHCI OverCurrentPME Enable	68h
Target Timeout Control	74h
MSI Control	D0h
MSI Address	D4h
MSI Data	D8h
HT MSI Support	E4h

2.2.1.2 USB1 & USB2 (Device-18/19 function 1) OHCI 1 – PCI Configuration Registers

Register Name	Offset Address
Device / Vendor ID	00h
Command	04h
Status	06h
Revision ID / Class Code	08h
Miscellaneous	0Ch
BAR_OHCI	10h
Subsystem Vendor ID / Subsystem ID	2Ch
Capability Pointer	34h
Interrupt Line	3Ch
MSI Control	D0h
MSI Address	D4h
MSI Data	D8h

Note : The PCI_Reg x40 ~ x7C only exists in the OHCI0, but not in any other OHCI controllers.

Device / Vendor ID – R - 32 bits - [PCI_Reg : 00h]			
Field Name	Bits	Default	Description
VEND_ID	15:0	1002h	Vendor ID
DEV_ID	31:16	Function 0: 4397h Function 1: 4398h	Device ID

Command – RW - 16 bits - [PCI_Reg : 04h]			
Field Name	Bits	Default	Description
IO Space Accesses	0	0b	A value of 0 disables the device response. A value of 1 allows the device to respond to I/O Space accesses.
Memory Space Accesses	1	0b	A value of 0 disables the device response. A value of 1 allows the device to respond to Memory Space accesses.
Bus Master	2	0b	A value of 0 disables the device from generating PCI accesses. A value of 1 allows the device to behave as a bus master.
Special Cycle	3	0b	Hardwired to 0, indicating no Special Cycle support.
Memory Write and Invalidate Command	4	0b	When it is 0, Memory Write must be used. When it is 1, masters may generate the command.
VGA Palette Register Accesses	5	0b	Hardwired to 0, indicating the device should treat palette write accesses like all other accesses.
Parity Enable	6	0b	When it is 1, the device must take its normal action when a parity error is detected. When it is 0, the device sets its Detected Parity Error status bit (bit 15 in the Status register) when an error is detected, but continues normal operations without asserting PERR#.
Reserved	7	0b	Hardwired to 0 per PCI2.3 spec.

Command – RW - 16 bits - [PCI_Reg : 04h]			
Field Name	Bits	Default	Description
SERR# Enable	8	0b	A value of 0 disables the SERR# driver. A value of 1 enables the SERR# driver. Address parity errors are reported only if this bit and bit [6] are 1.
Fast Back-to-Back Enable	9	0b	A value of 0 means only fast back-to-back transactions to the same agent are allowed. A value of 1 means the master is allowed to generate fast back-to-back transactions to different agents.
Interrupt Disable	10	0b	A value of 0 enables the assertion of the device/function's INTx# signal. A value of 1 disables the assertion of the device/function's INTx# signal.
Reserved	15:11		Reserved

Status – R - 16 bits - [PCI_Reg : 06h]			
Field Name	Bits	Default	Description
Reserved	2:0		Reserved
Interrupt Status	3	0b	This bit reflects the state of the interrupt in the device/function. Only when the Interrupt Disable bit in the command register is a 0 and this Interrupt Status bit is a 1 will the device's/function's INTx# signal be asserted. Setting the Interrupt Disable bit to a 1 has no effect on the state of this bit.
Capabilities List	4	1b	A value of 0 indicates that no New Capabilities linked list is available. A value of 1 indicates that the value read at offset 34h is a pointer in Configuration Space to a linked list of new capabilities.
66 MHz Capable	5	1b	Hardwired to 1, indicating 66MHz capable.
Reserved	6		Reserved
Fast Back-to-Back Capable	7	1b	Hard-wired to 1, indicating Fast Back-to-Back capable.
Master Data Parity Error	8	0b	This bit is set only when three conditions are met: (1) the bus agent asserted PERR# itself (on a read) or observed PERR# asserted (on a write); (2) the agent setting the bit acted as the bus master for the operation in which the error occurred; and (3) the Parity Error Response bit (Command register) is set.
DEVSEL timing	10:9	01b	Hardwired to 01b – medium timing
Signaled Target Abort	11	0b	This bit is set by a target device whenever it terminates a transaction with Target-Abort.
Received Target Abort	12	0b	This bit is set by a master device whenever its transaction is terminated with Target-Abort.
Received Master Abort	13	0b	This bit is set by a master device whenever its transaction (except for Special Cycle) is terminated with Master-Abort.
Signaled System Error	14	0b	This bit is set whenever the device asserts SERR#.
Detected Parity Error	15	0b	This bit is set by the device whenever it detects a parity error, even if parity error handling is disabled (as controlled by bit 6 in the Command register).

Revision ID / Class Code – R - 32 bits - [PCI_Reg : 08h]			
Field Name	Bits	Default	Description
Revision ID	7:0	00h	Revision ID.
PI	15:8	10h	Programming Interface. A constant value of '10h' identifies the device being an OpenHCI Host Controller.
SC	23:16	03h	Sub Class. A constant value of '03h' identifies the device being of Universal Serial Bus.
BC	31:24	0Ch	Base Class. A constant value of '0Ch' identifies the device being a Serial Bus Controller.

Miscellaneous – RW/R - 32 bits - [PCI_Reg : 0Ch]			
Field Name	Bits	Default	Description
Cache Line Size	7:0	00h	This read/write field specifies the system cacheline size in units of DWORDs and must be initialized to 00h.
Latency Timer	15:8	00h	[9:8] hard-wired to 00b, resulting in a timer granularity of at least four clocks. This field specifies, in units of PCI bus clocks, the value of the Latency Timer for this PCI bus master.
Header Type	23:16	80h/00h	This field identifies the layout of the second part of the predefined header (beginning at byte 10h in Configuration Space) and also whether or not the device contains multiple functions. Function 0: Bit [23] hardwired to 1 → the device has multiple functions. Function 1: Bit [23] hardwired to 0 → the device is single function. Bits [22:16]: Hard-wired to 00h.
BIST	31:24	00h	Hardwired to 00h, indicating no build-in BIST support.

Bar_OHCI – RW - 32 bits - [PCI_Reg : 10h]			
Field Name	Bits	Default	Description
IND	0	0b	Indicator. A constant value of '0' indicates that the operational registers of the device are mapped into memory space of the main memory of the PC host system. Read Only.
TP	2:1	0h	Type. A constant value of '00b' indicates that the base register is 32-bit wide and can be placed anywhere in the 32-bit memory space; i.e., lower 4 GB of the main memory of the PC host. Read Only.
PM	3	0b	Prefetch memory. A constant value of '0' indicates that there is no support for "prefetchable memory". Read Only.
	11:4	00h	Represents a maximum of 4-KB addressing space for the OpenHCI's operational registers. Read Only.
BAR	31:12	000h	Base Address. Specifies the upper 20 bits of the 32-bit starting base address. This represent a maximum of 4-KB addressing space for the OpenHCI's operational registers.

Subsystem Vendor ID / Subsystem ID – RW - 32 bits - [PCI_Reg : 2Ch]			
Field Name	Bits	Default	Description
Subsystem Vendor ID	15:0	0000h	Can only be written once by software.
Subsystem ID	31:16	0000h	Can only be written once by software.

Capability Pointer – R - 8 bits - [PCI_Reg : 34h]			
Field Name	Bits	Default	Description
Capability Pointer	7:0	D0h	Address of the 1 st element of capability link.

Interrupt Line – RW – 32 bits - [PCI_Reg : 3Ch]			
Field Name	Bits	Default	Description
Interrupt Line	7:0	00h	The Interrupt Line register is an eight-bit register used to communicate interrupt line routing information. The register is read/write and must be implemented by any device (or device function) that uses an interrupt pin. POST software will write the routing information into this register as it initializes and configures the system. The value in this register tells which input of the system interrupt controller(s) the device's interrupt pin is connected to. The device itself does not use this value; rather it is used by device drivers and operating systems. Device drivers and operating systems can use this information to determine priority and vector information. Values in this register are system architecture specific.
Interrupt Pin	15:8	01h	Read Only by default. OHCI0: Hard-wired to 01h, corresponding to using INTA#. OHCI1: Hard-wired to 01h, corresponding to using INTA#.
MIN_GNT	23:16	00h	Read Only. Hardwired to 00h to indicate no major requirements for the settings of Latency Timers.
MAX_LAT	31:24	00h	Read Only. Hardwired to 00h to indicate no major requirements for the settings of Latency Timers.
If Interrupt Backdoor Enable bit (OHCI0 regx50[7]) is set, this field is writable.			

Config Timers / MSI Disable (OHCI0 only) – RW - 16 bits - [PCI_Reg : 40h]			
Field Name	Bits	Default	Description
TRDY Timer	7:0	80h	Target Ready timer to timeout non-responding target.
MSI Disable	9:8	00h	When these bits are set MSI capability will be disabled for the corresponding Host Controller. Bit [8]: OHCI0 Bit [9]: OHCI1
Reserved	15:10	0h	Reserved

Port Disable (OHCI0 only) – RW* - 16 bits - [PCI_Reg : 42h]			
Field Name	Bits	Default	Description
Port_disable	5:0	00h	When these bits are set the corresponding ports are disabled. For example, if bit-0 is set then port-0 (its corresponding port) is disabled; if bit-1 is set, then its corresponding port (port-1) is disabled (and so on). Only value '1' can be written into the register. The bit can be cleared to '0' by system reset (PciRst#). In other words, when the bit is set to '1', the value is locked and cannot be cleared by any software write.
Reserved	15:6	00h	Reserved
Note: Only writing value '1' take effect to the register value, software writes '0' take no effect. The register can only be clear by hardware reset.			

OHCI Misc Control (OHCI0 only) – RW - 16 bits - [PCI_Reg : 50h]			
Field Name	Bits	Default	Description
OHCI Dynamic Power Saving Enable	0	0b	When this bit is set Dynamic Power Saving for OHCI is enabled . By default, the power saving function is disabled.
Reserved	7:1	00h	Reserved

OHCI Misc Control (OHCI0 only) – RW - 16 bits - [PCI_Reg: 50h]			
Field Name	Bits	Default	Description
OHCI Prefetch Cache Line Count	9:8	11b	Number of data cache line prefetch request for ISO out transaction. 00: Prefetch is disabled. 01: 1 cache line 10: 2 cache line 11: 3 cache line
OHCI Prefetch time out timer	11:10	00b	Time out timer to purge the prefetch data in AB data FIFO if the data is not used. 00: 255ms 01: 511ms 10: 767ms 11: 1023ms
SMI Handshake Disable	12	1b	If this bit is set the Handshake between USB and ACPI is disabled when SMI is requested by USB
Reserved	13	0h	Reserved
HcFm Enable	14	0b	Enable bit to write the HcFmRemaining and HcFmNumber registers. Set to "1" to enable the write to above mentioned registers. Set to "0" to disable the write to above mentioned registers.
Reserved	15	0h	Reserved

Over Current Control 1 (OHCI0 only) – R - 32 bits - [PCI_Reg : 58h]			
Field Name	Bits	Default	Description
Port0 OverCurrent Control	3:0	Fh	The register is to control the OverCurrent pin mapping for Port-0. There are 7 OverCurrent pins (USB_OC0 ~ USB_OC6), any value greater than 0x6h will disable the OverCurrent function for port-0.
Port1 OverCurrent Control	7:4	Fh	The register is to control the OverCurrent pin mapping for Port-1. There are 6 OverCurrent pins (USB_OC0 ~ USB_OC6), any value greater than 0x6h will disable the OverCurrent function for port-1.
Port2 OverCurrent Control	11:8	Fh	The register is to control the OverCurrent pin mapping for Port-2. There are 7 OverCurrent pins (USB_OC0 ~ USB_OC6), any value greater than 0x6h will disable the OverCurrent function for port-2.
Port3 OverCurrent Control	15:12	Fh	The register is to control the OverCurrent pin mapping for Port-3. There are 7 OverCurrent pins (USB_OC0 ~ USB_OC6), any value greater than 0x6h will disable the OverCurrent function for port-3.
Port4 OverCurrent Control	19:16	Fh	The register is to control the OverCurrent pin mapping for Port-4. There are 7 OverCurrent pins (USB_OC0 ~ USB_OC6), any value greater than 0x6h will disable the OverCurrent function for port-4.
Port5 OverCurrent Control	23:20	Fh	The register is to control the OverCurrent pin mapping for Port-5. There are 7 OverCurrent pins (USB_OC0 ~ USB_OC6), any value greater than 0x6h will disable the OverCurrent function for port-5.
Reserved	31:24	00h	Reserved.

Over Current Control 1 (OHCI0 only) – R - 32 bits - [PCI_Reg : 58h]			
Field Name	Bits	Default	Description
There are 7 pins can be used as USB OverCurrent function – USB_OC0#/GPM0#, USB_OC1#/GPM1#, USB_OC2#/GPM2#, USB_OC3#/IR_RX1/GPM3# USB_OC4#/IR_RX0/GPM4#, USB_OC5#/IR_TX0/GPM5#, USB_OC6#/IR_TX1/GEVENT6			
Register value-to-OverCurrent Pin mapping: USB_OC0# = 0000, USB_OC1# = 0001, USB_OC2# = 0010, USB_OC3# = 0011, USB_OC4# = 0100, USB_OC5# = 0101, USB_OC6# = 0110			
Note: Since OverCurrent pins can be used as GPM# as well, the corresponding register bits to set the pin as OverCurrent have to be set in Smbus Controller.			

OHCI OverCurrent PME Enable (OHCI0 only) – RW - 16 bits - [PCI_Reg : 68h]			
Field Name	Bits	Default	Description
OHCI OverCurrent PME Enable	5:0	00h	Writing this bit to a one enables the respective port to be sensitive to over-current conditions as wake-up events when it is owned by OHCI.
Reserved	15:6	00h	Reserved

Target Timeout Control (OHCI0 only) – RW - 32 bits - [PCI_Reg : 74h]			
Field Name	Bits	Default	Description
Retry counter	7:0	FFh	Counter to control the purge of the delay queue when the downstream access cycle is not completed within certain time. The transaction is target aborted when counter expired. The retry counter can be disabled by writing 00h in this Register.
Reserved	23:8	0000h	Reserved
Timeout Timer	31:24	80h	Timer to control the purge of the delay queue when the master that has initiated the access does not return to complete the transaction. After the timer expires the queue is invalidated and the next transaction is serviced.

MSI Control – RW - 32 bits - [PCI_Reg : D0h]			
Field Name	Bits	Default	Description
MSI USB	7:0	05h	MSI USB ID. Read only.
Next Item Pointer	15:8	00h	Pointer to next capability structure
MSI Control Out	16	0b	Set to 1 to disable IRQ. Use MSI instead.
Reserved	19:17	0h	Reserved
MSI Control	22:20	0h	MSI control field
Reserved	31:23	00h	Reserved

MSI Address – RW - 32 bits - [PCI_Reg : D4h]			
Field Name	Bits	Default	Description
Reserved	1:0		Reserved. Read-only.
MSI Address	31:2	0h	System-specified message address.

MSI Data – RW - 16 bits - [PCI_Reg : D8h]			
Field Name	Bits	Default	Description
MSI Data	15:0	0h	System-specified message.

2.2.2 USB3 (device-20, fun-5) OHCI PCI Configuration Registers

2.2.2.1 USB3 OHCI – PCI Configuration Registers

Register Name	Offset Address
Device / Vendor ID	00h
Command	04h
Status	06h
Revision ID / Class Code	08h
Miscellaneous	0Ch
BAR_OHCI	10h
Subsystem Vendor ID / Subsystem ID	2Ch
Capability Pointer	34h
Interrupt Line	3Ch
Config Timers / MSI Disable	40h – 41h
Port Disable Control	42h
OHCI Misc Control	50h
Over Current Control 1	58h
OHCI OverCurrent PME Enable	68h
Target Timeout Control	74h
MSI Control	D0h
MSI Address	D4h
MSI Data	D8h
HT MSI Support	E4h

Device / Vendor ID – R - 32 bits - [PCI_Reg : 00h]			
Field Name	Bits	Default	Description
VEND_ID	15:0	1002h	Vendor ID
DEV_ID	31:16	4399h	Device ID

Command – RW - 16 bits - [PCI_Reg : 04h]			
Field Name	Bits	Default	Description
IO Space Accesses	0	0b	A value of 0 disables the device response. A value of 1 allows the device to respond to I/O Space accesses.
Memory Space Accesses	1	0b	A value of 0 disables the device response. A value of 1 allows the device to respond to Memory Space accesses.
Bus Master	2	0b	A value of 0 disables the device from generating PCI accesses. A value of 1 allows the device to behave as a bus master.
Special Cycle	3	0b	Hard-wired to 0, indicating no Special Cycle support.
Memory Write and Invalidate Command	4	0b	When it is 0, Memory Write must be used. When it is 1, masters may generate the command.
VGA Palette Register Accesses	5	0b	Hard-wired to 0, indicating the device should treat palette write accesses like all other accesses.
Parity Enable	6	0b	When it is 1, the device must take its normal action when a parity error is detected. When it is 0, the device sets its Detected Parity Error status bit (bit 15 in the Status register) when an error is detected, but continues normal operations without asserting PERR#.
Reserved	7	0b	Hard-wired to 0 per PCI2.3 spec.
SERR# Enable	8	0b	A value of 0 disables the SERR# driver. A value of 1 enables the SERR# driver. Address parity errors are reported only if this bit and bit [6] are 1.
Fast Back-to-Back Enable	9	0b	A value of 0 means only fast back-to-back transactions to the same agent are allowed. A value of 1 means the master is allowed to generate fast back-to-back transactions to different agents.

Command – RW - 16 bits - [PCI_Reg : 04h]			
Field Name	Bits	Default	Description
Interrupt Disable	10	0b	A value of 0 enables the assertion of the device/function's INTx# signal. A value of 1 disables the assertion of the device/function's INTx# signal.
Reserved	15:11		Reserved

Status – R - 16 bits - [PCI_Reg : 06h]			
Field Name	Bits	Default	Description
Reserved	2:0		Reserved
Interrupt Status	3	0b	This bit reflects the state of the interrupt in the device/function. Only when the Interrupt Disable bit in the command register is a 0 and this Interrupt Status bit is a 1 will the device's/function's INTx# signal be asserted. Setting the Interrupt Disable bit to a 1 has no effect on the state of this bit.
Capabilities List	4	1b	A value of 0 indicates that no New Capabilities linked list is available. A value of 1 indicates that the value read at offset 34h is a pointer in Configuration Space to a linked list of new capabilities.
66 MHz Capable	5	1b	Hard-wired to 1, indicating 66MHz capable.
Reserved	6		Reserved
Fast Back-to-Back Capable	7	1b	Hard-wired to 1, indicating Fast Back-to-Back capable.
Master Data Parity Error	8	0b	This bit is set only when three conditions are met: (1) the bus agent asserted PERR# itself (on a read) or observed PERR# asserted (on a write); (2) the agent setting the bit acted as the bus master for the operation in which the error occurred; and (3) the Parity Error Response bit (Command register) is set.
DEVSEL timing	10:9	01b	Hard-wired to 01b – medium timing
Signaled Target Abort	11	0b	This bit is set by a target device whenever it terminates a transaction with Target-Abort.
Received Target Abort	12	0b	This bit is set by a master device whenever its transaction is terminated with Target-Abort.
Received Master Abort	13	0b	This bit is set by a master device whenever its transaction (except for Special Cycle) is terminated with Master-Abort.
Signaled System Error	14	0b	This bit is set whenever the device asserts SERR#.
Detected Parity Error	15	0b	This bit is set by the device whenever it detects a parity error, even if parity error handling is disabled (as controlled by bit 6 in the Command register).

Revision ID / Class Code – R - 32 bits - [PCI_Reg : 08h]			
Field Name	Bits	Default	Description
Revision ID	7:0	00h	Revision ID.
PI	15:8	10h	Programming Interface. A constant value of '10h' identifies the device being an OpenHCI Host Controller.
SC	23:16	03h	Sub Class. A constant value of '03h' identifies the device being of Universal Serial Bus.
BC	31:24	0Ch	Base Class. A constant value of '0Ch' identifies the device being a Serial Bus Controller.

Miscellaneous – RW/R - 32 bits - [PCI_Reg : 0Ch]			
Field Name	Bits	Default	Description
Cache Line Size	7:0	00h	This read/write field specifies the system cacheline size in units of DWORDs and must be initialized to 00h.
Latency Timer	15:8	00h	[9:8] hardwired to 00b, resulting in a timer granularity of at least four clocks. This field specifies, in units of PCI bus clocks, the value of the Latency Timer for this PCI bus master.

Miscellaneous – RW/R - 32 bits - [PCI_Reg : 0Ch]			
Field Name	Bits	Default	Description
Header Type	23:16	00h	This field identifies the layout of the second part of the predefined header (beginning at byte 10h in Configuration Space) and also whether or not the device contains multiple functions. Bits [22:16]: Hardwired to 00h.
BIST	31:24	00h	Hardwired to 00h, indicating no build-in BIST support.

Bar_OHCI – RW - 32 bits - [PCI_Reg : 10h]			
Field Name	Bits	Default	Description
IND	0	0b	Indicator. A constant value of '0' indicates that the operational registers of the device are mapped into memory space of the main memory of the PC host system. Read Only.
TP	2:1	0h	Type. A constant value of '00b' indicates that the base register is 32-bit wide and can be placed anywhere in the 32-bit memory space; i.e., lower 4 GB of the main memory of the PC host. Read Only.
PM	3	0b	Prefetch memory. A constant value of '0' indicates that there is no support for "prefetchable memory". Read Only.
	11:4	00h	Represents a maximum of 4-KB addressing space for the OpenHCI's operational registers. Read Only.
BAR	31:12	000h	Base Address. Specifies the upper 20 bits of the 32-bit starting base address. This represent a maximum of 4-KB addressing space for the OpenHCI's operational registers.

Subsystem Vendor ID / Subsystem ID – RW - 32 bits - [PCI_Reg : 2Ch]			
Field Name	Bits	Default	Description
Subsystem Vendor ID	15:0	0000h	Can only be written once by software.
Subsystem ID	31:16	0000h	Can only be written once by software.

Capability Pointer – R - 8 bits - [PCI_Reg : 34h]			
Field Name	Bits	Default	Description
Capability Pointer	7:0	D0h	Address of the 1 st element of capability link.

Interrupt Line – RW – 32 bits - [PCI_Reg : 3Ch]			
Field Name	Bits	Default	Description
Interrupt Line	7:0	00h	The Interrupt Line register is an eight-bit register used to communicate interrupt line routing information. The register is read/write and must be implemented by any device (or device function) that uses an interrupt pin. POST software will write the routing information into this register as it initializes and configures the system. The value in this register tells which input of the system interrupt controller(s) the device's interrupt pin is connected to. The device itself does not use this value; rather it is used by device drivers and operating systems. Device drivers and operating systems can use this information to determine priority and vector information. Values in this register are system architecture specific.
Interrupt Pin	15:8	03h	Read Only by default. OHCI: hard-wired to 03h, corresponding to using INTC# .
MIN_GNT	23:16	00h	Read Only. Hardwired to 00h to indicate no major requirements for the settings of Latency Timers.

Interrupt Line – RW – 32 bits - [PCI_Reg : 3Ch]			
Field Name	Bits	Default	Description
MAX_LAT	31:24	00h	Read Only. Hardwired to 00h to indicate no major requirements for the settings of Latency Timers.
If Interrupt Backdoor Enable bit (OHCI0 regx50[7]) is set, this field is writable.			

Config Timers / MSI Disable – RW - 16 bits - [PCI_Reg : 40h]			
Field Name	Bits	Default	Description
TRDY Timer	7:0	80h	Target Ready timer to timeout non-responding target.
MSI Disable	9:8	00h	When these bits are set MSI capability will be disabled for the corresponding Host Controller. Bit [8]: OHCI 0 Bit [9]: OHCI 1
Reserved	15:10	0h	Reserved

Port Disable – RW*- 16 bits - [PCI_Reg : 42h]			
Field Name	Bits	Default	Description
Port_disable	1:0	00h	When these bits are set the corresponding ports are disabled. For example, if bit-0 is set then port-12 (its corresponding port) is disabled; if bit-1 is set, then its corresponding port (port-13) is disabled. Only value '1' can be written into the register, the bit can be cleared to '0' by system reset (PciRst#). In other words, when the bit is set to '1', the value is locked and cannot be cleared by any software write.
Reserved	15:2	00h	Reserved
*Note: Only writing value '1' take effect to the register value, software writes '0' take no effect. The register can only be clear by hardware reset.			

Stand Alone Ports Pad Control (USB3 OHCI0 only) – RW - 16 bits - [PCI_Reg: 44h]			
Field Name	Bits	Default	Description
PSTR	1:0	01b	Driving strength for port12/13 IO pad P-mos transistors
Reserved	3:2	00b	Reserved
NSTR	5: 4	01b	Driving strength for port12/13 IO pad N-mos transistors
Reserved	7:6	00b	Reserved
Reserved	15:8	00h	Reserved

OHCI Misc Control (OHCI0 only) – RW - 16 bits - [PCI_Reg: 50h]			
Field Name	Bits	Default	Description
OHCI Dynamic Power Saving Enable	0	0	When this bit is set, Dynamic Power Saving for OHCI is enabled. By default, the Power Saving function is disabled.
Reserved	7:1	0	Reserved.
OHCI Prefetch Cache Line Count	9:8	11b	Number of data cache line prefetch request for ISO out transaction. 00: Prefetch is disabled. 01: 1 cache line 10: 2 cache line 11: 3 cache line

OHCI Misc Control (OHCI0 only) – RW - 16 bits - [PCI_Reg: 50h]			
Field Name	Bits	Default	Description
OHCI Prefetch time out timer	11:10	00b	Time out timer to purge the prefetch data in AB data FIFO if the data is not used. 00: 255ms 01: 511ms 10: 767ms 11: 1023ms
SMI Handshake Disable	12	1b	If this bit is set the Handshake between USB and ACPI is disabled when SMI is requested by USB
Reserved	15:13	0h	Reserved

Over Current Control 1 – R - 32 bits - [PCI_Reg : 58h]			
Field Name	Bits	Default	Description
Port12 OverCurrent Control	3:0	Fh	The register is to control the OverCurrent pin mapping for Port-12. There are 7 OverCurrent pins (USB_OC0 ~ USB_OC6), any value greater than 0x6h will disable the OverCurrent function for port-12.
Port13 OverCurrent Control	7:4	Fh	The register is to control the OverCurrent pin mapping for Port-13. There are 7 OverCurrent pins (USB_OC0 ~ USB_OC6), any value greater than 0x5h will disable the OverCurrent function for port-13.
Reserved	31:8		Reserved
<p>There are 7 pins can be used as USB OverCurrent function – USB_OC0#/GPM0#, USB_OC1#/GPM1#, USB_OC2#/GPM2#, USB_OC3#/IR_RX1/GPM3# USB_OC4#/IR_RX0/GPM4#, USB_OC5#/IR_TX0/GPM5#, USB_OC6#/IR_TX1/GEVENT6</p> <p>Register value-to-OverCurrent Pin mapping: USB_OC0# = 0000, USB_OC1# = 0001, USB_OC2# = 0010, USB_OC3# = 0011, USB_OC4# = 0100, USB_OC5# = 0101, USB_OC6# = 0110</p> <p>Note: Since OverCurrent pins can be used as GPM# as well, the corresponding register bits to set the pin as OverCurrent have to be set in Smbus Controller.</p>			

OHCI OverCurrent PME Enable – RW - 16 bits - [PCI_Reg : 68h]			
Field Name	Bits	Default	Description
OHCI OverCurrent PME Enable	1:0	00h	Writing this bit to a one enables the respective port to be sensitive to over-current conditions as wake-up events when it is owned by OHCI.
Reserved	15:10	00h	Reserved

Target Timeout Control – RW - 32 bits - [PCI_Reg : 74h]			
Field Name	Bits	Default	Description
Retry counter	7:0	FFh	Counter to control the purge of the delay queue when the host controller does not return the ack. After the counter expires the transaction is target aborted. The retry counter can be disabled by writing 00h in this Register.
Reserved	23:8	0000h	Reserved
Timeout Timer	31:24	80h	Timer to control the purge of the delay queue when the master that has initiated the access does not return to complete the transaction. After the timer expires the queue is invalidated and the next transaction is serviced.

MSI Control – RW - 32 bits - [PCI_Reg : D0h]			
Field Name	Bits	Default	Description
MSI USB	7:0	05h	MSI USB ID. Read only.
Next Item Pointer	15:8	00h	Pointer to next capability structure
MSI Control Out	16	0b	Set to 1 to disable IRQ. Use MSI instead.
Reserved	19:17	0h	Reserved
MSI Control	22:20	0h	MSI control field
Reserved	31:23	00h	Reserved

MSI Address – RW - 32 bits - [PCI_Reg : D4h]			
Field Name	Bits	Default	Description
Reserved	1:0		Reserved, read-only.
MSI Address	31:2	0h	System-specified message address.

MSI Data – RW - 16 bits - [PCI_Reg : D8h]			
Field Name	Bits	Default	Description
MSI Data	15:0	0h	System-specified message.

2.2.3 USB1, USB2 & USB3 (Device-18, 19 & Device-20 fun-5) OHCI Memory Mapped Registers

Register Name	Offset Address
HcRevision	0h
HcControl	4h
HcCommandStatus	8h
HcInterruptStatus	Ch
HcInterruptEnable	10h
HcInterruptDisable	14h
HcHCCA	18h
HcPeriodCurrentED	1Ch
HcControlHeadED	20h
HcControlCurrentED	24h
HcBulkHeadED	28h
HcBulkCurrentED	2Ch
HcDoneHead	30h
HcFmInterval	34h
HcFmRemaining	38h
HcFmNumber	3Ch
HcPeriodicStart	40h
HcLSThreshold	44h
HcRhDescriptorA	48h
HcRhDescriptorB	4Ch
HCRhStatus	50h
HcRhPortStatus[1]	54h
...	...
HcRhPortStatus[NDP]	54+4*NDP
OHCI Loop Back feature Support	F0h

HcRevision - R - 32 bits - [MEM_Reg : 00h]			
Field Name	Bits	Default	Description
REV	7:0	10h	Revision. This read-only field contains the version of HCI specification.

HcRevision - R - 32 bits - [MEM_Reg : 00h]			
Field Name	Bits	Default	Description
L	8	1b	Legacy This read-only field is 1, indicating that the legacy support registers are present in this HC.
Reserved	31:9		

HcControl - 32 bits - [MEM_Reg : 04h]					
Field Name	Bits	Default	HCD	HC	Description
CBSR	1:0	00b	RW	R	<p>ControlBulkServiceRatio</p> <p>This specifies the service ratio between Control and Bulk Eds. Before processing any of the nonperiodic lists, HC must compare the ratio specified with its internal count on how many nonempty Control Eds have been processed, in determining whether to continue serving another Control ED or switching to Bulk Eds.</p> <p style="text-align: center;">CBSR No. of Control Eds Over Bulk Eds Served</p> <p style="text-align: center;">0 1:1 1 2:1 2 3:1 3 4:1</p>
PLE	2	0b	RW	R	<p>PeriodicListEnable</p> <p>This bit is set to enable the processing of the periodic list in the next Frame. If cleared by HCD, processing of the periodic list does not occur after the next SOF. HC must check this bit before it starts processing the list.</p>
IE	3	0b	RW	R	<p>IsochronousEnable</p> <p>This bit is used by HCD to enable/disable processing of isochronous Eds. While processing the periodic list in a Frame, HC checks the status of this bit when it finds an Isochronous ED (F=1). If set (enabled), HC continues processing the Eds. If cleared (disabled), HC halts processing of the periodic list (which now contains only isochronous Eds) and begins processing the Bulk/Control lists. Setting this bit is guaranteed to take effect in the next Frame (not the current Frame).</p>
CLE	4	0b	RW	R	<p>ControlListEnable</p> <p>This bit is set to enable the processing of the Control list in the next Frame. If cleared by HCD, processing of the Control list does not occur after the next SOF. HC must check this bit whenever it determines to process the list. When disabled, HCD may modify the list. If HcControlCurrentED is pointing to an ED to be removed, HCD must advance the pointer by updating HcControlCurrentED before re-enabling processing of the list.</p>

HcControl - 32 bits - [MEM_Reg : 04h]					
Field Name	Bits	Default	HCD	HC	Description
BLE	5	0b	RW	R	<p>BulkListEnable</p> <p>This bit is set to enable the processing of the Bulk list in the next Frame. If cleared by HCD, processing of the Bulk list does not occur after the next SOF. HC checks this bit whenever it determines to process the list. When disabled, HCD may modify the list. If <i>HcBulkCurrentED</i> is pointing to an ED to be removed, HCD must advance the pointer by updating <i>HcBulkCurrentED</i> before re-enabling processing of the list.</p>
HCFS	7:6	00b	RW	RW	<p>HostControllerFunctionalState for USB</p> <p>00b: USBRESET 01b: USBRESUME 10b: USBOPERATIONAL 11b: USBSUSPEND</p> <p>A transition to USBOPERATIONAL from another state causes SOF generation to begin 1 ms later. HCD may determine whether HC has begun sending SOFs by reading the StartofFrame field of <i>HcInterruptStatus</i>.</p> <p>This field may be changed by HC only when in the USBSUSPEND state. HC may move from the USBSUSPEND state to the USBRESUME state after detecting the resume signaling from a downstream port.</p> <p>HC enters USBSUSPEND after a software reset, whereas it enters USBRESET after a hardware reset. The latter also resets the Root Hub and asserts subsequent reset signaling to downstream ports.</p>
IR	8	0b	RW	R	<p>InterruptRouting</p> <p>This bit determines the routing of interrupts generated by events registered in <i>HcInterruptStatus</i>. If clear, all interrupts are routed to the normal host bus interrupt mechanism. If set, interrupts are routed to the System Management Interrupt. HCD clears this bit upon a hardware reset, but it does not alter this bit upon a software reset. HCD uses this bit as a tag to indicate the ownership of HC.</p>
RWC	9	0b	RW	RW	<p>RemoteWakeupConnected</p> <p>This bit indicates whether HC supports remote wakeup signaling. If remote wakeup is supported and used by the system it is the responsibility of system firmware to set this bit during POST. HC clears the bit upon a hardware reset but does not alter it upon a software reset. Remote wakeup signaling of the host system is host-bus-specific and is not described in this specification.</p>
RWE	10	0b	RW	R	<p>RemoteWakeupEnable</p> <p>This bit is used by HCD to enable or disable the remote wakeup feature upon the detection of upstream resume signaling. When this bit is set and the <i>ResumeDetected</i> bit in <i>HcInterruptStatus</i> is set, a remote wakeup is signaled to the host system. Setting this bit has no impact on the generation of hardware interrupt.</p>
Reserved	31:11				

HcCommandStatus - 32 bits - [MEM_Reg : 08h]					
Field Name	Bits	Default	HCD	HC	Description
HCR	0	0b	RW	RW	<p>HostControllerReset</p> <p>This bit is set by HCD to initiate a software reset of HC. Regardless of the functional state of HC, it moves to the USB_SUSPEND state in which most of the operational registers are reset except those stated otherwise; e.g., the <i>InterruptRouting</i> field of <i>HcControl</i>, and no Host bus accesses are allowed. This bit is cleared by HC upon the completion of the reset operation. The reset operation must be completed within 10 ms. This bit, when set, should not cause a reset to the Root Hub and no subsequent reset signaling should be asserted to its downstream ports.</p>
CLF	1	0b	RW	RW	<p>ControlListFilled</p> <p>This bit is used to indicate whether there are any TDs on the Control list. It is set by HCD whenever it adds a TD to an ED in the Control list. When HC begins to process the head of the Control list, it checks CLF. As long as <i>ControlListFilled</i> is 0, HC will not start processing the Control list. If CLF is 1, HC will start processing the Control list and will set <i>ControlListFilled</i> to 0. If HC finds a TD on the list, then HC will set <i>ControlListFilled</i> to 1 causing the Control list processing to continue. If no TD is found on the Control list, and if the HCD does not set <i>ControlListFilled</i>, then <i>ControlListFilled</i> will still be 0 when HC completes processing the Control list and Control list processing will stop.</p>
BLF	2	0b	RW	RW	<p>BulkListFilled</p> <p>This bit is used to indicate whether there are any TDs on the Bulk list. It is set by HCD whenever it adds a TD to an ED in the Bulk list. When HC begins to process the head of the Bulk list, it checks BF. As long as <i>BulkListFilled</i> is 0, HC will not start processing the Bulk list. If <i>BulkListFilled</i> is 1, HC will start processing the Bulk list and will set BF to 0. If HC finds a TD on the list, then HC will set <i>BulkListFilled</i> to 1 causing the Bulk list processing to continue. If no TD is found on the Bulk list, and if HCD does not set <i>BulkListFilled</i>, then <i>BulkListFilled</i> will still be 0 when HC completes processing the Bulk list and Bulk list processing will stop.</p> <p><i>BulkListFilled</i></p> <p>This bit is used to indicate whether there are any TDs on the Bulk list. It is set by HCD whenever it adds a TD to an ED in the Bulk list. When HC begins to process the head of the Bulk list, it checks BF. As long as <i>BulkListFilled</i> is 0, HC will not start processing the Bulk list. If <i>BulkListFilled</i> is 1, HC will start processing the Bulk list and will set BF to 0. If HC finds a TD on the list, then HC will set <i>BulkListFilled</i> to 1 causing the Bulk list processing to continue. If no TD is found on the Bulk list, and if HCD does not set <i>BulkListFilled</i>, then <i>BulkListFilled</i> will still be 0 when HC completes processing the Bulk list and Bulk list processing will stop.</p>

HcCommandStatus - 32 bits - [MEM_Reg : 08h]					
Field Name	Bits	Default	HCD	HC	Description
OCR	3	0b	RW	RW	OwnershipChangeRequest This bit is set by an OS HCD to request a change of control of the HC. When set HC will set the OwnershipChange field in <i>HcInterruptStatus</i> . After the changeover, this bit is cleared and remains so until the next request from OS HCD.
Reserved	15:4				
SOC	17:16	00b	R	RW	SchedulingOverrunCount These bits are incremented on each scheduling overrun error. It is initialized to 00b and wraps around at 11b. This will be incremented when a scheduling overrun is detected even if SchedulingOverrun in <i>HcInterruptStatus</i> has already been set. This is used by HCD to monitor any persistent scheduling problems.
Reserved	31:18				

HcInterruptStatus RW - 32 bits - [MEM_Reg : 0Ch]					
Field Name	Bits	Default	HCD	HC	Description
SO	0	0b	RW	RW	SchedulingOverrun This bit is set when the USB schedule for the current Frame overruns and after the update of <i>HccaFrameNumber</i> . A scheduling overrun will also cause the SchedulingOverrunCount of <i>HcCommandStatus</i> to be incremented.
WDH	1	0b	RW	RW	WritebackDoneHead This bit is set immediately after HC has written <i>HcDoneHead</i> to <i>HccaDoneHead</i> . Further updates of the <i>HccaDoneHead</i> will not occur until this bit has been cleared. HCD should only clear this bit after it has saved the content of <i>HccaDoneHead</i> .
SF	2	0b	RW	RW	StartoffFrame This bit is set by HC at each start of a frame and after the update of <i>HccaFrameNumber</i> . HC also generates a SOF token at the same time.
RD	3	0b	RW	RW	ResumeDetected This bit is set when HC detects that a device on the USB is asserting resume signaling. It is the transition from no resume signaling to resume signaling causing this bit to be set. This bit is not set when HCD sets the USBRESUME state.
UE	4	0b	RW	RW	UnrecoverableError This bit is set when HC detects a system error not related to USB. HC should not proceed with any processing nor signaling before the system error has been corrected. HCD clears this bit after HC has been reset.
FNO	5	0b	RW	RW	FrameNumberOverflow This bit is set when the MSb of <i>HcFmNumber</i> (bit 15) changes value, from 0 to 1 or from 1 to 0, and after <i>HccaFrameNumber</i> has been updated.
RHSC	6	0b	RW	RW	RootHubStatusChange This bit is set when the content of <i>HcRhStatus</i> or the content of any of <i>HcRhPortStatus</i> [NumberOfDownstreamPort] has changed.
Reserved	29:7				

HcInterruptStatus RW - 32 bits - [MEM_Reg : 0Ch]					
Field Name	Bits	Default	HCD	HC	Description
OC	30	0b	RW	RW	OwnershipChange This bit is set by HC when HCD sets the OwnershipChangeRequest field in <i>HcCommandStatus</i> . This event, when unmasked, will always generate an System Management Interrupt (SMI) immediately. This bit is tied to 0b when the SMI pin is not implemented.
Reserved	31				

HcInterruptEnable- 32 bits - [MEM_Reg : 10h]					
Field Name	Bits	Default	HCD	HC	Description
SO	0	0b	RW	RW	0: Ignore 1: Enable interrupt generation due to Scheduling Overrun.
WDH	1	0b	RW	RW	0: Ignore 1: Enable interrupt generation due to HcDoneHead Writeback.
SF	2	0b	RW	RW	0: Ignore 1: Enable interrupt generation due to Start of Frame.
RD	3	0b	RW	W	0: Ignore 1: Enable interrupt generation due to Resume Detect.
UE	4	0b	RW	RW	0: Ignore 1: Enable interrupt generation due to Unrecoverable Error.
FNO	5	0b	RW	RW	0: Ignore 1: Enable interrupt generation due to Frame Number Overflow.
RHSC	6	0b	RW	RW	0: Ignore 1: Enable interrupt generation due to Root Hub Status Change.
Reserved	29:7				
OC	30	0b	RW	RW	0: Ignore 1: Enable interrupt generation due to Ownership Change.
MIE	31	0b	RW	R	A '0' written to this field is ignored by HC. A '1' written to this field enables interrupt generation due to events specified in the other bits of this register. This is used by HCD as a Master Interrupt Enable.

HcInterruptDisable - 32 bits - [MEM_Reg : 14h]					
Field Name	Bits	Default	HCD	HC	Description
SO	0	0b	RW	R	0: Ignore 1: Disable interrupt generation due to Scheduling Overrun.
WDH	1	0b	RW	R	0: Ignore 1: Disable interrupt generation due to HcDoneHead Writeback.
SF	2	0b	RW	R	0: Ignore 1: Disable interrupt generation due to Start of Frame.
RD	3	0b	RW	R	0: Ignore 1: Disable interrupt generation due to Resume Detect.
UE	4	0b	RW	R	0: Ignore 1: Disable interrupt generation due to Unrecoverable Error.
FNO	5	0b	RW	R	0: Ignore 1: Disable interrupt generation due to Frame Number Overflow.
RHSC	6	0b	RW	R	0: Ignore 1: Disable interrupt generation due to Root Hub Status Change.
Reserved	29:7				
OC	30	0b	RW	R	0: Ignore 1: Disable interrupt generation due to Ownership Change.
MIE	31	0b	RW	R	A '0' written to this field is ignored by HC. A '1' written to this field disables interrupt generation due to events specified in the other bits of this register. This field is set after a hardware or software reset.

HcHCCA - 32 bits - [MEM_Reg : 18h]					
Field Name	Bits	Default	HCD	HC	Description
Reserved	7:0				
HCCA	31:8	000000h	RW	R	This is the base address of the Host Controller Communication Area

HcPeriodCurrentED - 32 bits - [MEM_Reg : 1Ch]					
Field Name	Bits	Default	HCD	HC	Description
Reserved	3:0				
PCED	31:4	0000000h	R	RW	PeriodCurrentED This is used by HC to point to the head of one of the Periodic lists which will be processed in the current Frame. The content of this register is updated by HC after a periodic ED has been processed. HCD may read the content in determining which ED is currently being processed at the time of reading.

HcControlHeadED- 32 bits - [MEM_Reg : 20h]					
Field Name	Bits	Default	HCD	HC	Description
Reserved	3:0				
CHED	31:4	0000000h	RW	R	ControlHeadED HC traverses the Control list starting with the <i>HcControlHeadED</i> pointer. The content is loaded from HCCA during the initialization of HC.

HcControlCurrentED RW - 32 bits - [MEM_Reg : 24h]					
Field Name	Bits	Default	HCD	HC	Description
Reserved	3:0				
CCED	31:4	0000000h	RW	RW	ControlCurrentED This pointer is advanced to the next ED after serving the present one. HC will continue processing the list from where it left off in the last Frame. When it reaches the end of the Control list, HC checks the ControlListFilled of in <i>HcCommandStatus</i> . If set, it copies the content of <i>HcControlHeadED</i> to <i>HcControlCurrentED</i> and clears the bit. If not set, it does nothing. HCD is allowed to modify this register only when the ControlListEnable of <i>HcControl</i> is cleared. When set, HCD only reads the instantaneous value of this register. Initially, this is set to zero to indicate the end of the Control list.

HcBulkHeadED - 32 bits - [MEM_Reg : 28h]					
Field Name	Bits	Default	HCD	HC	Description
Reserved	3:0				
BHED	31:4	0b	RW	R	BulkHeadED HC traverses the Bulk list starting with the <i>HcBulkHeadED</i> pointer. The content is loaded from HCCA during the initialization of HC.

HcBulkCurrentED- RW - 32 bits - [MEM_Reg : 2Ch]					
Field Name	Bits	Default	HCD	HC	Description
Reserved	3:0				
BCED	31:4	0000000h	RW	RW	BulkCurrentED This is advanced to the next ED after the HC has served the present one. HC continues processing the list from where it left off in the last Frame. When it reaches the end of the Bulk list, HC checks the ControlListFilled of <i>HcControl</i> . If set, it copies the content of <i>HcBulkHeadED</i> to <i>HcBulkCurrentED</i> and clears the bit. If it is not set, it does nothing. HCD is only allowed to modify this register when the BulkListEnable of <i>HcControl</i> is cleared. When set, the HCD only reads the instantaneous value of this register. This is initially set to zero to indicate the end of the Bulk list.

HcDoneHead- 32 bits - [MEM_Reg : 30h]					
Field Name	Bits	Default	HCD	HC	Description
Reserved	3:0				
DH	31:4	0b	R	RW	DoneHead When a TD is completed, HC writes the content of <i>HcDoneHead</i> to the NextTD field of the TD. HC then overwrites the content of <i>HcDoneHead</i> with the address of this TD. This is set to zero whenever HC writes the content of this register to HCCA. It also sets the WritebackDoneHead of <i>HcInterruptStatus</i> .

HcFmInterval - 32 bits - [MEM_Reg : 34h]					
Field Name	Bits	Default	HCD	HC	Description
FI	13:0	2EDFh	RW	R	FrameInterval This specifies the interval between two consecutive SOFs in bit times. The nominal value is set to be 11,999. HCD should store the current value of this field before resetting HC. By setting the HostControllerReset field of <i>HcCommandStatus</i> as this will cause the HC to reset this field to its nominal value. HCD may choose to restore the stored value upon the completion of the Reset sequence.
Reserved	15:14				
FSMPS	30:16	0000h	RW	R	FSLargestDataPacket This field specifies a value which is loaded into the Largest Data Packet Counter at the beginning of each frame. The counter value represents the largest amount of data in bits which can be sent or received by the HC in a single transaction at any given time without causing scheduling overrun. The field value is calculated by the HCD.
FIT	31	0b	RW	R	FrameIntervalToggle HCD toggles this bit whenever it loads a new value to FrameInterval

HcFmRemaining - 32 bits - [MEM_Reg : 38h]					
Field Name	Bits	Default	HCD	HC	Description
FR	13:0	0000h	R	RW	FrameRemaining This counter is decremented at each bit time. When it reaches zero, it is reset by loading the FrameInterval value specified in <i>HcFmInterval</i> at the next bit time boundary. When entering the USBOPERATIONAL state, HC re-loads the content with the FrameInterval of <i>HcFmInterval</i> and uses the updated value from the next SOF.
Reserved	30:14				
FRT	31	0b	R	RW	FrameRemainingToggle This bit is loaded from the FrameIntervalToggle field of <i>HcFmInterval</i> whenever FrameRemaining reaches 0. This bit is used by HCD for the synchronization between FrameInterval and FrameRemaining .

HcFmNumber - 32 bits - [MEM_Reg : 3Ch]					
Field Name	Bits	Default	HCD	HC	Description
FN	15:0	0000h	R	RW	This is incremented when <i>HcFmRemaining</i> is re-loaded. It will be rolled over to 0h after ffffh. When entering the USBOPERATIONAL state, this will be incremented automatically. The content will be written to HCCA after HC has incremented the FrameNumber at each frame boundary and sent a SOF but before HC reads the first ED in that Frame. After writing to HCCA, HC will set the StartofFrame in <i>HcInterruptStatus</i> .
Reserved	31:16				

HcPeriodicStart - 32 bits - [MEM_Reg : 40h]					
Field Name	Bits	Default	HCD	HC	Description
PS	13:0	0000h	RW	R	PeriodicStart After a hardware reset, this field is cleared. This is then set by HCD during the HC initialization. The value is calculated roughly as 10% off from <i>HcFmInterval</i> . A typical value will be 3E67h. When <i>HcFmRemaining</i> reaches the value specified, processing of the periodic lists will have priority over Control/Bulk processing. HC will therefore start processing the Interrupt list after completing the current Control or Bulk transaction that is in progress.
Reserved	31:14				

HcLSThreshold - 32 bits - [MEM_Reg : 44h]					
Field Name	Bits	Default	HCD	HC	Description
LST	11:0	0628h	RW	R	LSThreshold This field contains a value which is compared to the FrameRemaining field prior to initiating a Low Speed transaction. The transaction is started only if FrameRemaining is greater than this field. The value is calculated by HCD with the consideration of transmission and setup overhead.
Reserved	31:12				

HcRhDescriptorA- 32 bits - [MEM_Reg : 48h]					
Field Name	Bits	Default	HCD	HC	Description
NDP	7:0	03h (USB1/2) or 02h (USB3)	R	R	NumberDownstreamPorts These bits specify the number of downstream ports supported by the Root Hub. It is implementation-specific. The minimum number of ports is 1. The maximum number of ports supported by OpenHCI is 15. Note: For USB1/USB2 (device-18/19) OHCI controllers each owns 3 downstream ports For USB3 (device-20, fun-5) OHCI controller owns 2 downstream ports.
PSM	8	0b	RW	R	PowerSwitchingMode This bit is used to specify how the power switching of the Root Hub ports is controlled. It is implementation-specific. This field is only valid if the NoPowerSwitching field is cleared. 0: All ports are powered at the same time. 1: Each port is powered individually. This mode allows port power to be controlled by either the global switch or per-port switching. If the PortPowerControlMask bit is set, the port responds only to port power commands (Set/ClearPortPower). If the port mask is cleared, then the port is controlled only by the global power switch (Set/ClearGlobalPower).
NPS	9	1b	RW	R	NoPowerSwitching These bits are used to specify whether power switching is supported or port are always powered. It is implementation-specific. When this bit is cleared, the PowerSwitchingMode specifies global or per-port switching. 0: Ports are power switched 1: Ports are always powered on when the HC is powered on

HcRhDescriptorA- 32 bits - [MEM_Reg : 48h]					
Field Name	Bits	Default	HCD	HC	Description
DT	10	0b	R	R	DeviceType This bit specifies that the Root Hub is not a compound device. The Root Hub is not permitted to be a compound device. This field should always read/write 0.
OCPM	11	1b	RW	R	OverCurrentProtectionMode This bit describes how the overcurrent status for the Root Hub ports are reported. At reset, this field should reflect the same mode as PowerSwitchingMode . This field is valid only if the NoOverCurrentProtection field is cleared. 0: Over-current status is reported collectively for all downstream ports 1: Over-current status is reported on a per-port basis
NOCP	12	0b	RW	R	NoOverCurrentProtection This bit describes how the overcurrent status for the Root Hub ports are reported. When this bit is cleared, the OverCurrentProtectionMode field specifies global or per-port reporting. 0: Over-current status is reported collectively for all downstream ports 1: No overcurrent protection supported
Reserved	23:13				
POTPGT	31:24	02h	RW	R	PowerOnToPowerGoodTime This byte specifies the duration HCD has to wait before accessing a powered-on port of the Root Hub. It is implementation-specific. The unit of time is 2 ms. The duration is calculated as POTPGT * 2 ms.

HcRhDescriptorB- 32 bits - [MEM_Reg : 4Ch]					
Field Name	Bits	Default	HCD	HC	Description
DR	15:0	0000h	RW	R	DeviceRemovable Each bit is dedicated to a port of the Root Hub. When cleared, the attached device is removable. When set, the attached device is not removable. Bit [0]: Reserved Bit [1]: Device attached to Port #1 Bit [2]: Device attached to Port #2 ... Bit [15]: Device attached to Port #15
PPCM	31:16	0000h	RW	R	PortPowerControlMask Each bit indicates if a port is affected by a global power control command when PowerSwitchingMode is set. When set, the port's power state is only affected by per-port power control (Set/ClearPortPower). When cleared, the port is controlled by the global power switch (Set/ClearGlobalPower). If the device is configured to global switching mode (PowerSwitchingMode=0), this field is not valid. Bit [0]: Reserved Bit [1]: Ganged-power mask on Port #1 Bit [2]: Ganged-power mask on Port #2 ... Bit [15]: Ganged-power mask on Port #15

HcRhStatus- 32 bits - [MEM_Reg : 50h]					
Field Name	Bits	Default	HCD	HC	Description
LPS	0	0b	RW	R	<p>(Read) LocalPowerStatus The Root Hub does not support the local power status feature; thus, this bit is always read as '0'.</p> <p>(Write) ClearGlobalPower In global power mode (PowerSwitchingMode=0), This bit is written to '1' to turn off power to all ports (clear PortPowerStatus). In per-port power mode, it clears PortPowerStatus only on ports whose PortPowerControlMask bit is not set. Writing a '0' has no effect.</p>
OCI	1	0b	R	RW	<p>OverCurrentIndicator This bit reports overcurrent conditions when the global reporting is implemented. When set, an overcurrent condition exists. When cleared, all power operations are normal. If per-port overcurrent protection is implemented this bit is always '0'</p>
Reserved	14:2				
DRWE	15	0b	RW	R	<p>(Read) DeviceRemoteWakeupEnable This bit enables a ConnectStatusChange bit as a resume event, causing a USBSUSPEND to USBRESUME state transition and setting the ResumeDetected interrupt.</p> <p>0: ConnectStatusChange is not a remote wakeup event. 1: ConnectStatusChange is a remote wakeup event.</p> <p>(Write) SetRemoteWakeupEnable Writing a '1' sets DeviceRemoveWakeupEnable. Writing a '0' has no effect.</p>
LPSC	16	0b	RW	R	<p>(Read) LocalPowerStatusChange The Root Hub does not support the local power status feature; thus, this bit is always read as '0'.</p> <p>(Write) SetGlobalPower In global power mode (PowerSwitchingMode=0), This bit is written to '1' to turn on power to all ports (clear PortPowerStatus). In per-port power mode, it sets PortPowerStatus only on ports whose PortPowerControlMask bit is not set. Writing a '0' has no effect.</p>
OCIC	17	0b	RW	RW	<p>OverCurrentIndicatorChange This bit is set by hardware when a change has occurred to the OCI field of this register. The HCD clears this bit by writing a '1'. Writing a '0' has no effect.</p>
Reserved	30:18				
CRWE	31	-	W	R	<p>(Write) ClearRemoteWakeupEnable Writing a '1' clears DeviceRemoveWakeupEnable. Writing a '0' has no effect.</p>

HcRhPortStatus - RW - 32 bits - [MEM_Reg : 50h+4*(1:NDP)]					
Field Name	Bits	Default	HCD	HC	Description
CCS	0	0b	RW	RW	<p>(Read) CurrentConnectStatus This bit reflects the current state of the downstream port.</p> <p>0: No device connected 1: Device connected</p> <p>(Write) ClearPortEnable The HCD writes a '1' to this bit to clear the PortEnableStatus bit. Writing a '0' has no effect. The CurrentConnectStatus is not affected by any write. Note: This bit is always read '1b' when the attached device is nonremovable (DeviceRemoveable[NDP]).</p>
PES	1	0b	RW	RW	<p>(Read) PortEnableStatus This bit indicates whether the port is enabled or disabled. The Root Hub may clear this bit when an overcurrent condition, disconnect event, switched-off power, or operational bus error such as babble is detected. This change also causes PortEnabledStatusChange to be set. HCD sets this bit by writing SetPortEnable and clears it by writing ClearPortEnable. This bit cannot be set when CurrentConnectStatus is cleared. This bit is also set, if not already, at the completion of a port reset when ResetStatusChange is set or port suspend when SuspendStatusChange is set.</p> <p>0: Port is disabled 1: Port is enabled</p> <p>(Write) SetPortEnable The HCD sets PortEnableStatus by writing a '1'. Writing a '0' has no effect. If CurrentConnectStatus is cleared, this write does not set PortEnableStatus, but instead sets ConnectStatusChange. This informs the driver that it attempted to enable a disconnected port.</p>

HcRhPortStatus - RW - 32 bits - [MEM_Reg : 50h+4*(1:NDP)]					
Field Name	Bits	Default	HCD	HC	Description
PSS	2	0b	RW	RW	<p>(Read) PortSuspendStatus This bit indicates the port is suspended or in the resume sequence. It is set by a SetSuspendState write and cleared when PortSuspendStatusChange is set at the end of the resume interval. This bit cannot be set if CurrentConnectStatus is cleared. This bit is also cleared when PortResetStatusChange is set at the end of the port reset or when the HC is placed in the USBRESUME state. If an upstream resume is in progress, it should propagate to the HC.</p> <p>0: Port is not suspended 1: Port is suspended</p> <p>(Write) SetPortSuspend The HCD sets the PortSuspendStatus bit by writing a '1' to this bit. Writing a '0' has no effect. If CurrentConnectStatus is cleared, this write does not set PortSuspendStatus; instead it sets ConnectStatusChange. This informs the driver that it attempted to suspend a disconnected port.</p>
POCI	3	0b	RW	RW	<p>(Read) PortOverCurrentIndicator This bit is only valid when the Root Hub is configured in such a way that overcurrent conditions are reported on a per-port basis. If per-port overcurrent reporting is not supported, this bit is set to 0. If cleared, all power operations are normal for this port. If set, an overcurrent condition exists on this port. This bit always reflects the overcurrent input signal</p> <p>0: No overcurrent condition. 1: Overcurrent condition detected.</p> <p>(Write) ClearSuspendStatus The HCD writes a '1' to initiate a resume. Writing a '0' has no effect. A resume is initiated only if PortSuspendStatus is set.</p>
PRS	4	0b	RW	RW	<p>(Read) PortResetStatus When this bit is set by a write to SetPortReset, port reset signaling is asserted. When reset is completed, this bit is cleared when PortResetStatusChange is set. This bit cannot be set if CurrentConnectStatus is cleared.</p> <p>0: Port reset signal is not active 1: Port reset signal is active</p> <p>(Write) SetPortReset The HCD sets the port reset signaling by writing a '1' to this bit. Writing a '0' has no effect. If CurrentConnectStatus is cleared, this write does not set PortResetStatus, but instead sets ConnectStatusChange. This informs the driver that it attempted to reset a disconnected port.</p>
Reserved	7:5				

HcRhPortStatus - RW - 32 bits - [MEM_Reg : 50h+4*(1:NDP)]					
Field Name	Bits	Default	HCD	HC	Description
PPS	8	0b	RW	RW	<p>(Read) PortPowerStatus This bit reflects the port's power status, regardless of the type of power switching implemented. This bit is cleared if an overcurrent condition is detected. HCD sets this bit by writing SetPortPower or SetGlobalPower. HCD clears this bit by writing ClearPortPower or ClearGlobalPower. Which power control switches are enabled is determined by PowerSwitchingMode and PortPortControlMask[NDP]. In global switching mode, (PowerSwitchingMode=0), only Set/ClearGlobalPower controls this bit. In per-port power switching (PowerSwitchingMode=1), if the PortPowerControlMask[NDP] bit for the port is set, only Set/ClearPortPower commands are enabled. If the mask is not set, only Set/ClearGlobalPower commands are enabled. When port power is disabled, CurrentConnectStatus, PortEnableStatus, PortSuspendStatus, and PortResetStatus should be reset.</p> <p>0: Port power is off 1: Port power is on</p> <p>(Write) SetPortPower The HCD writes a '1' to set the PortPowerStatus bit. Writing a '0' has no effect. Note: This bit is always reads '1b' if power switching is not supported.</p>
LSDA	9	X	RW	RW	<p>(Read) LowSpeedDeviceAttached This bit indicates the speed of the device attached to this port. When set, a Low Speed device is attached to this port. When clear, a Full Speed device is attached to this port. This field is valid only when the CurrentConnectStatus is set.</p> <p>0: Full speed device attached 1: Low speed device attached</p> <p>(Write) ClearPortPower The HCD clears the PortPowerStatus bit by writing a '1' to this bit. Writing a '0' has no effect.</p>
Reserved	15:10				
CSC	16	0b	RW	RW	<p>ConnectStatusChange This bit is set whenever a connect or disconnect event occurs. The HCD writes a '1' to clear this bit. Writing a '0' has no effect. If CurrentConnectStatus is cleared when a SetPortReset, SetPortEnable, or SetPortSuspend write occurs, this bit is set to force the driver to re-evaluate the connection status since these writes should not occur if the port is disconnected.</p> <p>0: No change in CurrentConnectStatus 1: Change in CurrentConnectStatus</p> <p>Note: If the DeviceRemovable[NDP] bit is set, this bit is set only after a Root Hub reset to inform the system that the device is attached.</p>

HcRhPortStatus - RW - 32 bits - [MEM_Reg : 50h+4*(1:NDP)]					
Field Name	Bits	Default	HCD	HC	Description
PESC	17	0b	RW	RW	<p>PortEnableStatusChange This bit is set when hardware events cause the PortEnableStatus bit to be cleared. Changes from HCD writes do not set this bit. The HCD writes a '1' to clear this bit. Writing a '0' has no effect. 0: No change in PortEnableStatus 1: Change in PortEnableStatus</p>
PSSC	18	0b	RW	RW	<p>PortSuspendStatusChange This bit is set when the full resume sequence has been completed. This sequence includes the 20-s resume pulse, LS EOP, and 3-ms resynchronization delay. The HCD writes a '1' to clear this bit. Writing a '0' has no effect. This bit is also cleared when ResetStatusChange is set. 0: Resume is not completed 1: Resume completed</p>
OCIC	19	0b	RW	RW	<p>PortOverCurrentIndicatorChange This bit is valid only if overcurrent conditions are reported on a per-port basis. This bit is set when Root Hub changes the PortOverCurrentIndicator bit. The HCD writes a '1' to clear this bit. Writing a '0' has no effect. 0: No change in PortOverCurrentIndicator 1: PortOverCurrentIndicator has changed</p>
PRSC	20	0b	RW	RW	<p>PortResetStatusChange This bit is set at the end of the 10-ms port reset signal. The HCD writes a '1' to clear this bit. Writing a '0' has no effect. 0: Port reset is not complete 1: Port reset is complete</p>
Reserved	31:21				

Legacy Support Registers

Five operational registers are used to provide the legacy support. Each of these registers is located on a 32-bit boundary. The offset of these registers is relative to the base address of the Host Controller operational registers with HceControl located at offset 100h.

Table 2-1 Legacy Support Registers

Offset	Register	Description
100h	HceControl	Used to enable and control the emulation hardware and report various status information.
104h	HceInput	Emulation side of the legacy Input Buffer register.
108h	HceOutput	Emulation side of the legacy Output Buffer register where keyboard and mouse data is to be written by software.
10Ch	HceStatus	Emulation side of the legacy Status register.
160h	OHCI Legacy IRQ Routing	Present in OHCI 0 only. Used to enable /block the routing of legacy IRQ 1 and 12 through USB controller.

Three of the operational registers (HceStatus, HceInput, HceOutput) are accessible at I/O address 60h and 64h when emulation is enabled.

Table 2-2 Emulated Registers

I/O Address	Cycle Type	Register Contents Accessed/Modified	Side Effects
60h	IN	HceOutput	IN from port 60h will set OutputFull in HceStatus to 0
60h	OUT	HceInput	OUT to port 60h will set InputFull to 1 and CmdData to 0 in HceStatus.
64h	IN	HceStatus	IN from port 64h returns current value of HceStatus with no other side effect.
64h	OUT	HceInput	OUT to port 64h will set InputFull to 0 and CmdData in HceStatus to 1.

HceInput Register

HceInput –RW - 32 bits			
Field Name	Bits	Default	Description
InputData	7:0	00h	This register holds data that is written to I/O ports 60h and 64h.
Reserved	31:8		

I/O data that is written to ports 60h and 64h is captured in this register when emulation is enabled. This register may be read or written directly by accessing it with its memory address in the Host Controller's operational register space. When accessed directly with a memory cycle, reads and writes of this register have no side effects.

HceOutput Register

HceOutput –RW - 32 bits			
Field Name	Bits	Default	Description
OutputData	7:0	00h	This register hosts data that is returned when an I/O read of port 60h is performed by application software.
Reserved	31:8		

The data placed in this register by the emulation software is returned when I/O port 60h is read and emulation is enabled. On a read of this location, the **OutputFull** bit in HceStatus is set to 0.

HceStatus Register

HceStatus –RW - 32 bits			
Field Name	Bits	Default	Description
OutputFull	0	0b	The HC sets this bit to 0 on a read of I/O port 60h. If IRQEn is set and AuxOutputFull is set to 0, then an IRQ1 is generated as long as this bit is set to 1. If IRQEn is set and AuxOutputFull is set to 1, then an IRQ12 is generated as long as this bit is set to 1. While this bit is 0 and CharacterPending in HceControl is set to 1, an emulation interrupt condition exists.
InputFull	1	0b	Except for the case of a Gate A20 sequence, this bit is set to 1 on an I/O write to address 60h or 64h. While this bit is set to 1 and emulation is enabled, an emulation interrupt condition exists.
Flag	2	0b	Nominally used as a system flag by software to indicate a warm or cold boot.
CmdData	3	0b	The HC sets this bit to 0 on an I/O write to port 60h and to 1 on an I/O write to port 64h.
Inhibit Switch	4	0b	This bit reflects the state of the keyboard inhibit switch and is set if the keyboard is NOT inhibited.
AuxOutputFull	5	0b	IRQ12 is asserted whenever this bit is set to 1 and OutputFull is set to 1 and the IRQEn bit is set.
Time-out	6	0b	Used to indicate a time-out
Parity	7	0b	Indicates parity error on keyboard/mouse data.
Reserved	31:8		

The contents of the HceStatus Register are returned on an I/O Read of port 64h when emulation is enabled. Reads and writes of port 60h and writes to port 64h can cause changes in this register. Emulation software can directly access this register through its memory address in the Host Controller's operational register space. Accessing this register through its memory address produces no side effects.

HceControl Register

HceControl - 32 bits			
Field Name	Bits	Reset	Description
EmulationEnable	0	0b	When set to 1, the HC is enabled for legacy emulation. The HC decodes accesses to I/O registers 60h and 64h and generates IRQ1 and/or IRQ12 when appropriate. Additionally, the HC generate s an emulation interrupt at appropriate times to invoke the emulation software.
EmulationInterrupt	1	-	This bit is a static decode of the emulation interrupt condition. [Read-only]
CharacterPending	2	0b	When set, an emulation interrupt is generated when the <i>OutputFull</i> bit of the <i>HceStatus</i> register is set to 0.
IRQEn	3	0b	When set, the HC generates IRQ1 or IRQ12 as long as the <i>OutputFull</i> bit in <i>HceStatus</i> is set to 1. If the <i>AuxOutputFull</i> bit of <i>HceStatus</i> is 0, then IRQ1 is generated; if it is 1, then an IRQ12 is generated.
ExternalIRQEn	4	0b	When set to 1, IRQ1 and IRQ12 from the keyboard controller causes an emulation interrupt. The function controlled by this bit is independent of the setting of the <i>EmulationEnable</i> bit in this register.
GateA20Sequence	5	0b	Set by HC when a data value of D1h is written to I/O port 64h. Cleared by HC on write to I/O port 64h of any value other than D1h.
IRQ1Active	6	0b	Indicates that a positive transition on IRQ1 from keyboard controller has occurred. SW may write a 1 to this bit to clear it (set it to 0). SW write of a 0 to this bit has no effect.
IRQ12Active	7	0b	Indicates that a positive transition on IRQ12 from keyboard controller has occurred. SW may write a 1 to this bit to clear it (set it to 0). SW write of a 0 to this bit has no effect.
A20State	8	0b	Indicates current state of Gate A20 on keyboard controller. Used to compare against value written to 60h when <i>GateA20Sequence</i> is active.
Reserved	31:9	-	Must read as 0s.

OHCI Legacy IRQ Routing

OHCI Legacy IRQ Routing- WO – 32 bits			
Field Name	Bits	Default	Description
Legacy IRQ Routing	3:0	3h	This register bits control the ownership of legacy IRQ routing. Bit[0] – “1” = enable IRQ 1 Bit[1] – “1” = enable IRQ 12 Bit [2] – “1” = block IRQ 1 Bit [3] – “1” = block IRQ 12 The register is present in OHCI 0 controller only.
Reserved	31:4	00h	Reserved

2.2.4 USB1/ USB2 EHCI PCI Configuration Registers

Registers Name	Offset Address
Device / Vendor ID	00h
Command	04h
Status	06h
Revision ID / Class Code	08h
Miscellaneous	0Ch
Base Address – BAR_EHCI	10h
Subsystem ID / Subsystem Vendor ID	2Ch
Capability Pointer	34h
Interrupt Line	3Ch
EHCI Misc Control	50h
EHCI PCI Spare 1	54h
Serial Bus Release Number – SBRN	60h
Frame Length Adjustment – FLADJ	61h
Port Wake Capability – PORTWAKECAP	62h
PME Control	C0h
PME Data / Status	C4h
MSI Control	D0h
MSI Address	D4h
MSI Data	D8h
EHCI Debug Port Support	E4h
USB Legacy Support Extended Capability – USBLEGSUP	EECP+0h ¹
USB Legacy Support Control/Status - USBLEGCTLSTS	EECP+4h ¹

¹The EECP field is in the read-only HCCPARAMS register [MEM_Reg: 08h] with the value of A0h.

DEVICE / VENDOR ID – R - 32 bits - [PCI_Reg : 00h]			
Field Name	Bits	Default	Description
VEND_ID	15:0	1002h	Vendor ID
DEV_ID	31:16	Function 2: 4396h	Device ID

Command – RW - 16 bits - [PCI_Reg : 04h]			
Field Name	Bits	Default	Description
IO Space Accesses	0	0b	A value of 0 disables the device response. A value of 1 allows the device to respond to I/O Space accesses.

Command – RW - 16 bits - [PCI_Reg : 04h]			
Field Name	Bits	Default	Description
Memory Space Accesses	1	0b	A value of 0 disables the device response. A value of 1 allows the device to respond to Memory Space accesses.
Bus Master	2	0b	A value of 0 disables the device from generating PCI accesses. A value of 1 allows the device to behave as a bus master.
Special Cycle	3	0b	Hard-wired to 0, indicating no Special Cycle support.
Memory Write and Invalidate Command	4	0b	When it is 0, Memory Write must be used. When it is 1, masters may generate the command.
VGA Palette Register Accesses	5	0b	Hard-wired to 0, indicating the device should treat palette write accesses like all other accesses.
Parity Enable	6	0b	When it is 1, the device must take its normal action when a parity error is detected. When it is 0, the device sets its Detected Parity Error status bit (bit 15 in the Status register) when an error is detected, but does not assert PERR# and continues normal operation.
Reserved	7	0b	Hard-wired to 0 per PCI2.3 spec.
SERR# Enable	8	0b	A value of 0 disables the SERR# driver. A value of 1 enables the SERR# driver. Address parity errors are reported only if this bit and bit [6] are 1.
Fast Back-to-Back Enable	9	0b	A value of 0 means fast back-to-back transactions to the same agent only are allowed. A value of 1 means the master is allowed to generate fast back-to-back transactions to different agents.
Interrupt Disable	10	0b	A value of 0 enables the assertion of the device/function's INTx# signal. A value of 1 disables the assertion of the device/function's INTx# signal.
Reserved	15:11		Reserved

Status – R - 16 bits - [PCI_Reg : 06h]			
Field Name	Bits	Default	Description
Reserved	2:0		Reserved
Interrupt Status	3	0b	This bit reflects the state of the interrupt in the device/function. Only when the Interrupt Disable bit in the command register is a 0 and this Interrupt Status bit is a 1, will the device's/function's INTx# signal be asserted. Setting the Interrupt Disable bit to a 1 has no effect on the state of this bit.
Capabilities List	4	1b	A value of 0 indicates that no New Capabilities linked list is available. A value of 1 indicates that the value read at offset 34h is a pointer in Configuration Space to a linked list of new capabilities.
66 MHz Capable	5	1b	Hard-wired to 1, indicating 66MHz capable.
Reserved	6		Reserved
Fast Back-to-Back Capable	7	1b	Hard-wired to 1, indicating Fast Back-to-Back capable.
Master Data Parity Error	8	0b	This bit is set only when three conditions are met: (1) the bus agent asserted PERR# itself (on a read) or observed PERR# asserted (on a write); (2) the agent setting the bit acted as the bus master for the operation in which the error occurred; and (3) the Parity Error Response bit (Command register) is set.
DEVSEL timing	10:9	01b	Hard-wired to 01b – medium timing
Signaled Target Abort	11	0b	This bit is set by a target device whenever it terminates a transaction with Target-Abort.

Status – R - 16 bits - [PCI_Reg : 06h]			
Field Name	Bits	Default	Description
Received Target Abort	12	0b	This bit is set by a master device whenever its transaction is terminated with Target-Abort.
Received Master Abort	13	0b	This bit is set by a master device whenever its transaction (except for Special Cycle) is terminated with Master-Abort.
Signaled System Error	14	0b	This bit is set whenever the device asserts SERR#.
Detected Parity Error	15	0b	This bit is set by the device whenever it detects a parity error, even if parity error handling is disabled (as controlled by bit 6 in the Command register).

Revision ID / Class Code – R - 32 bits - [PCI_Reg : 08h]			
Field Name	Bits	Default	Description
Revision ID	7:0	00h	Revision ID.
PI	15:8	20h	Programming Interface. A constant value of '20h' identifies the device being an EHCI Host Controller.
SC	23:16	03h	Sub Class. A constant value of '03h' identifies the device being of Universal Serial Bus.
BC	31:24	0Ch	Base Class. A constant value of '0Ch' identifies the device being a Serial Bus Controller.

Miscellaneous – RW - 32 bits - [PCI_Reg : 0Ch]			
Field Name	Bits	Default	Description
Cache Line Size	7:0	00h	This read/write field specifies the system cacheline size in units of DWORDs and must be initialized to 00h.
Latency Timer	15:8	00h	[9:8] hard-wired to 00b, resulting in a timer granularity of at least four clocks. This field specifies, in units of PCI bus clocks, the value of the Latency Timer for this PCI bus master.
Header Type	23:16	00h	This field identifies the layout of the second part of the predefined header (beginning at byte 10h in Configuration Space) and also whether or not the device contains multiple functions. EHCI has single function and bits [23:16] are hardwired to 00h. Read Only.
BIST	31:24	00h	Hardwired to 00h, indicating no build-in BIST support.

BAR_EHCI – RW - 32 bits - [PCI_Reg : 10h]			
Field Name	Bits	Default	Description
IND	0	0b	Indicator. A constant value of '0' indicates that the operational registers of the device are mapped into memory space of the main memory of the PC host system. Read Only.
TP	2:1	0h	Type. A constant value of '00b' indicates that the base register is 32-bit wide and can be placed anywhere in the 32-bit memory space; i.e., lower 4 GB of the main memory of the PC host. Read Only.
PM	3	0b	Prefetch Memory. A constant value of '0' indicates that there is no support for "prefetchable memory". Read Only.
Reserved	7:4	0h	Read Only.
BA	31:8	0h	Base Address. Corresponds to memory address signals [31:8].

BAR_EHCI – RW - 32 bits - [PCI_Reg : 10h]			
Field Name	Bits	Default	Description
BAR register. Base address used for the memory mapped capability and operational registers.			

Subsystem ID / Subsystem Vendor ID – RW - 32 bits - [PCI_Reg : 2Ch]			
Field Name	Bits	Default	Description
Subsystem Vendor ID	15:0	0000h	Can only be written once by software.
Subsystem ID	31:16	0h	Can only be written once by software.

Capability Pointer – R - 8 bits - [PCI_Reg : 34h]			
Field Name	Bits	Default	Description
Capability Pointer	7:0	C0h (* Note)	Address of the 1 st element of capability link.
Note: If PME Capability is disabled by setting PME Disable bit (PCI Register x50[5]), then Capability pointer contains MSI Capability pointer DCh. If MSI Capability is disabled by setting MSI Disable bit (PCI Register x50[6]), then Capability pointer contains Debug Port Capability Pointer xE4h.			

Interrupt Line - RW - 32 bits - [PCI_Reg : 3Ch]			
Field Name	Bits	Default	Description
Interrupt Line	7:0	00h	The Interrupt Line is a field used to communicate interrupt line routing information. The register is read/write and must be implemented by any device (or device function) that uses an interrupt pin. POST software will write the routing information into this register as it initializes and configures the system. The value in this field tells which input of the system interrupt controller(s) the device's interrupt pin is connected to. The device itself does not use this value; rather it is used by device drivers and operating systems. Device drivers and operating systems can use this information to determine priority and vector information. Values in this register are system architecture specific.
Interrupt Pin	15:8	02h (See Note)	Read Only by default. EHCI Hard-wired to 02h, which corresponds to using INTB#.
MIN_GNT	23:16	00h	Read Only. Hard-wired to 00h to indicate no major requirements for the settings of Latency Timers.
MAX_LAT	31:24	00h	Read Only. Hard-wired to 00h to indicate no major requirements for the settings of Latency Timers.
Note: If Interrupt Backdoor Enable bit (OHC10 regx50[7]) is set, this field is writable.			

EHCI Misc Control – RW - 32 bits - [PCI_Reg : 50h]			
Field Name	Bits	Default	Description
Reserved	4:0	0h	Reserved
PME Disable	5	0b	Set to 1 to disable PME support
MSI Disable	6	0b	Set to 1 to disable MSI support
Delay Tolerant	7	0b	Set to 0 to disable Delay Tolerant logic. Setting of '1' is not supported. Applies to revision A14 and above.
Reserved	15:8	0h	Reserved

EHCI Misc Control – RW - 32 bits - [PCI_Reg : 50h]																																																						
Field Name	Bits	Default	Description																																																			
Cache Timer Control	19:16	Eh	Control the purge timeout timer if HC doesn't come back to request the data. <table border="1"> <thead> <tr> <th>Counter</th> <th>Max Time (ns)</th> <th>Min Time (ns)</th> </tr> </thead> <tbody> <tr><td>0</td><td>45</td><td>30</td></tr> <tr><td>1</td><td>90</td><td>60</td></tr> <tr><td>2</td><td>180</td><td>120</td></tr> <tr><td>3</td><td>360</td><td>240</td></tr> <tr><td>4</td><td>720</td><td>480</td></tr> <tr><td>5</td><td>1440</td><td>960</td></tr> <tr><td>6</td><td>2880</td><td>1920</td></tr> <tr><td>7</td><td>5760</td><td>3840</td></tr> <tr><td>8</td><td>11520</td><td>7680</td></tr> <tr><td>9</td><td>23040</td><td>15360</td></tr> <tr><td>A</td><td>46080</td><td>30720</td></tr> <tr><td>B</td><td>92160</td><td>61440</td></tr> <tr><td>C</td><td>184320</td><td>122880</td></tr> <tr><td>D</td><td>368640</td><td>245760</td></tr> <tr><td>E</td><td>737280</td><td>491520</td></tr> <tr><td>F</td><td>No limit</td><td></td></tr> </tbody> </table>	Counter	Max Time (ns)	Min Time (ns)	0	45	30	1	90	60	2	180	120	3	360	240	4	720	480	5	1440	960	6	2880	1920	7	5760	3840	8	11520	7680	9	23040	15360	A	46080	30720	B	92160	61440	C	184320	122880	D	368640	245760	E	737280	491520	F	No limit	
				Counter	Max Time (ns)	Min Time (ns)																																																
				0	45	30																																																
				1	90	60																																																
				2	180	120																																																
				3	360	240																																																
				4	720	480																																																
				5	1440	960																																																
				6	2880	1920																																																
				7	5760	3840																																																
				8	11520	7680																																																
				9	23040	15360																																																
				A	46080	30720																																																
				B	92160	61440																																																
C	184320	122880																																																				
D	368640	245760																																																				
E	737280	491520																																																				
F	No limit																																																					
Reserved	22:20	000b	Reserved																																																			
Async Park Mode Disable	23	0b	Set to 1 to disable async-park mode.																																																			
Reserved	24	0b	Reserved																																																			
Disable Async QH Cache	25	0b	Set to 1 to disable async QH/QTD cache.																																																			
Disable Async Data Cache	26	0b	Set to 1 to disable async data cache request.																																																			
Disable Periodic List Cache	27	0b	Set to 1 to disable periodic list cache.																																																			
Disable Async QH Cache Enhancement	28	0b	Set to 1 to disable async QH/QTD cache enhancement.																																																			
Reserved	30:29	0h	Reserved																																																			
PHY Advance Power Saving Enable	31	0b	Set to 1 to enable the advance PHY power saving feature to save active power from USBPHY.																																																			

EHCI Spare 1 – RW - 32 bits - [PCI_Reg : 54h]			
Field Name	Bits	Default	Description
Reserved	31:0	0h	Reserved

SBRN – R - 8 bits - [PCI_Reg : 60h]			
Field Name	Bits	Default	Description
SBRN	7:0	20h	Hard-wired to 20h.

FLADJ – RW - 8 bits - [PCI_Reg : 61h]																							
Field Name	Bits	Default	Description																				
FLADJ	5:0	20h	<p>Frame Length Timing Value. Each decimal value change to this register corresponds to 16 high-speed bit times. The SOF cycle time (number of SOF counter clock periods to generate a SOF micro-frame length) is equal to 59488 + value in this field. The default value is decimal 32 (20h), which gives a SOF cycle time of 60000.</p> <table border="1"> <thead> <tr> <th>FLADJ Value in decimals [hexadecimal value]</th> <th>Frame Length (# High Speed bit times in decimals)</th> </tr> </thead> <tbody> <tr> <td>0 [00h]</td> <td>59488</td> </tr> <tr> <td>1 [01h]</td> <td>59504</td> </tr> <tr> <td>2 [02h]</td> <td>59520</td> </tr> <tr> <td>...</td> <td>...</td> </tr> <tr> <td>31 [1Fh]</td> <td>59984</td> </tr> <tr> <td>32 [20h]</td> <td>60000</td> </tr> <tr> <td>...</td> <td>...</td> </tr> <tr> <td>62 [3Eh]</td> <td>60480</td> </tr> <tr> <td>63 [3Fh]</td> <td>60496</td> </tr> </tbody> </table>	FLADJ Value in decimals [hexadecimal value]	Frame Length (# High Speed bit times in decimals)	0 [00h]	59488	1 [01h]	59504	2 [02h]	59520	31 [1Fh]	59984	32 [20h]	60000	62 [3Eh]	60480	63 [3Fh]	60496
FLADJ Value in decimals [hexadecimal value]	Frame Length (# High Speed bit times in decimals)																						
0 [00h]	59488																						
1 [01h]	59504																						
2 [02h]	59520																						
...	...																						
31 [1Fh]	59984																						
32 [20h]	60000																						
...	...																						
62 [3Eh]	60480																						
63 [3Fh]	60496																						
Reserved	7:6		Reserved.																				

PORTWAKECAP – RW - 16 bits - [PCI_Reg : 62h] (Not Implemented)			
Field Name	Bits	Default	Description
Port Wake Up Capability Mask	15:0	0000h	Bit position zero of this register indicates whether the register is implemented. A one in bit position zero indicates that the register is implemented. Bit positions 1 through 15 correspond to a physical port implemented on this host controller. For example, bit position 1 corresponds to port 1, position 2 to port 2, etc.

Note: This register is optional by spec and we did not implement it.

PME Control – RW - 32 bits - [PCI_Reg : C0h]			
Field Name	Bits	Default	Description
Cap_ID	7:0	01h	Read only. A value of "01h" identifies the linked list item as being the PCI Power Management registers.
Next ItemPointer	15:8	D0h	Read only. This field provides an offset into the function's PCI Configuration Space pointing to the location of next item in the function's capability list. If there are no additional items in the Capabilities List, this register is set to 00h.
Version	18:16	010b	Read only. A value of "010b" indicates that this function complies with Revision 1.1 of the PCI Power Management Interface Specification.
PME clock	19	0b	Read only. When this bit is a "0", it indicates that no PCI clock is required for the function to generate PME# .
Reserved	20		Reserved
DSI	21	0b	Read only. The Device Specific Initialization bit indicates whether special initialization of this function is required (beyond the standard PCI configuration header) before the generic class device driver is able to use it.

PME Control – RW - 32 bits - [PCI_Reg : C0h]			
Field Name	Bits	Default	Description
Aux_Current	24:22	000b	Read only. This 3 bit field reports the 3.3Vaux auxiliary current requirements for the PCI function. If the Data Register has been implemented by this function: <ul style="list-style-type: none"> • Reads of this field must return a value of “000b”. • The Data Register takes precedence over this field for 3.3Vaux current requirement reporting.
D1_Support	25	1b	If this bit is a “1”, this function supports the D1 Power Management State.
D2_Support	26	1b	If this bit is a “1”, this function supports the D2 Power Management State.
PME_Support	31:27	0Fh	Read only. This 5-bit field indicates the power states in which the function may assert PME#. A value of 0b for any bit indicates that the function is not capable of asserting the PME# signal while in that power state. Bit [31] 1XXXXb: PME# can be asserted from D3cold Bit [30] X1XXXb: PME# can be asserted from D3hot Bit [29] XX1XXb: PME# can be asserted from D2 Bit [28] XXX1Xb: PME# can be asserted from D1 Bit [27] XXXX1b: PME# can be asserted from D0

PME Data / Status – RW - 32 bits - [PCI_Reg : C4h]			
Field Name	Bits	Default	Description
PowerState	1:0	00b	This 2-bit field is used both to determine the current power state of a function and to set the function into a new power state. The definition of the field values is given below. 00b: D0 01b: D1 10b: D2 11b: D3hot If software attempts to write an unsupported, optional state to this field, the write operation must be completed normally on the bus; however, the data is discarded and no state change occurs.
Reserved	7:2		Reserved
PME_En	8	0b	A “1” enables the function to assert PME#. When “0”, PME# assertion is disabled. This bit defaults to “0” if the function does not support PME# generation from D3cold.
Data_Select	12:9	0000b	This 4-bit field is used to select which data is to be reported through the Data register and Data_Scale field.
Data_Scale	14:13	00b	This 2-bit read-only field indicates the scaling factor to be used when interpreting the value of the Data register. The value and meaning of this field will vary depending on which data value has been selected by the Data_Select field.
PME_Status	15	0b	This bit is set when the function would normally assert the PME# signal independent of the state of the PME_En bit.
Reserved	21:16		Reserved
B2_B3#	22	1b	Read only. The state of this bit determines the action that is to occur as a direct result of programming the function to D3hot. A “1” indicates that when the bridge function is programmed to D3hot, its secondary bus’s PCI clock will be stopped (B2).

PME Data / Status – RW - 32 bits - [PCI_Reg : C4h]			
Field Name	Bits	Default	Description
BPCC_En	23	0b	Read only. A “0” indicates that the bus power/clock control policies are disabled. When the Bus Power/Clock Control mechanism is disabled, the bridge’s PMCSR PowerState field cannot be used by the system software to control the power or clock of the bridge’s secondary bus.
Data	31:24	00h	Read only. This register is used to report the state dependent data requested by the Data_Select field. The value of this register is scaled by the value reported by the Data_Scale field.

MSI Control – RW - 32 bits - [PCI_Reg : D0h]			
Field Name	Bits	Default	Description
MSI USB	7:0	05h	MSI USB ID. Read only.
Next Item Pointer	15:8	E4h	Pointer to next capability structure
MSI Control Out	16	0b	Set to 1 to disable IRQ. Use MSI instead.
Reserved	19:17	0h	Reserved
MSI Control	22:20	0h	MSI control field
64-bit Address Capable	23	0b	If EHCI is in 64 bit address mode as specified by 64-bit Addressing Capability bit in HCCPARAMS register [MEM Reg: 08h] , this bit is set to 1 indicating that EHCI is capable of generating a 64-bit message address. Otherwise it is set to 0 indicating the EHCI is not capable of generating a 64-bit address. Read only
Reserved	31:24	00h	Reserved

MSI Address – RW - 32 bits - [PCI_Reg : D4h]			
Field Name	Bits	Default	Description
MSI Address	31:0	0h	System-specified message address.

MSI Upper Address – RW - 32 bits - [PCI_Reg : D8h] (* Note)			
Field Name	Bits	Default	Description
MSI Upper Address (See Note)	31:0	0h	If the Message Enable bit (bit 0 of the Message Control register) is set, the contents of this register (if non-zero) specify the upper 32-bits of a 64-bit message address (AD[63::32]). If the contents of this register are zero, the device uses the 32 bit address specified by the message address register.
Note: If EHCI is in 64 bit address mode as specified by 64-bit Addressing Capability bit in HCCPARAMS register [MEM Reg: 08h] , xD8 contains the higher 32 bits of the MSI Address and xDC contains the MSI Data. Otherwise xD8 contains MSI Data.			

MSI Data – RW - 16 bits - [PCI_Reg : D8h/DCh] (* Note)			
Field Name	Bits	Default	Description
MSI Data (See Note)	15:0	0h	System-specified message
Note: If EHCI is in 64 bit address mode as specified by 64-bit Addressing Capability bit in HCCPARAMS register [MEM Reg: 08h] , xD8 contains the higher 32 bits of the MSI Address and xDC contains the MSI Data. Otherwise xD8 contains MSI Data.			

DEBUG_PRT Control – RO - 32 bits - [PCI_Reg : E4h]			
Field Name	Bits	Default	Description
CAP_ID	7:0	0Ah	The value of 0Ah in this field identifies that the function supports a Debug Port.
Next Item Pointer	15:8	00h	Pointer to next capability structure
Offset	28:16	0E0h	This 12 bit field indicates the byte offset (up to 4K) within the BAR indicated by <i>BAR#</i> . This offset is required to be DWORD aligned and therefore bits 16 and 17 are always zero.
Bar #	31:29	1h	A 3-bit field, which indicates which one of the possible 6 Base Address Register offsets, contains the Debug Port registers. For example, a value of 1h indicates the first BAR (offset 10h) while a value of 5 indicates that the BAR at 20h. This offset is independent as to whether the BAR is 32 or 64 bit. For example, if the offset were 3 indicating that the BAR at offset 18h contains the Debug Port. BARs at offset 10 and 14h may or may not be implemented. This field is read only and only values 1-6h are valid. (A 64-bit BAR is allowed.) Only a memory BAR is allowed.

USBLEGSUP – RW - 32 bits - [PCI_Reg : EECF + 00h] (* Note)			
Field Name	Bits	Default	Description
Capability ID	7:0	01h	This field identifies the extended capability. A value of 01h identifies the capability as Legacy Support. This extended capability requires one additional 32-bit register for control/status information, and this register is located at offset EECF+04h. Read Only.
Next EHCI Extended Capability Pointer	15:8	00h	This field points to the PCI configuration space offset of the next extended capability pointer. A value of 00h indicates the end of the extended capability list. Read Only.
HC BIOS Owned Semaphore	16	0b	The BIOS sets this bit to establish ownership of the EHCI controller. System BIOS will set this bit to a zero in response to a request for ownership of the EHCI controller by system software.
Reserved	23:17		These bits are reserved and must be set to zero.
HC OS Owned Semaphore	24	0b	System software sets this bit to request ownership of the EHCI controller. Ownership is obtained when this bit reads as one and the HC BIOS Owned Semaphore bit reads as zero.
Reserved	31:25		These bits are reserved and must be set to zero.
Note: EECF is defined in HCCPARAMS reg[15:8] (EHCI MEM x08) and is hard-wired to xA0.			

USBLEGCTLSTS – RW - 32 bits - [PCI_Reg : EECF + 04h] (* Note)			
Field Name	Bits	Default	Description
USB SMI Enable	0	0b	When this bit is a one, and the <i>SMI on USB Complete</i> bit (above) in this register is a one, the host controller will issue an SMI immediately.
SMI on USB Error Enable	1	0b	When this bit is a one, and the <i>SMI on USB Error</i> bit (above) in this register is a one, the host controller will issue an SMI immediately.
SMI on Port Change Enable	2	0b	When this bit is a one, and the <i>SMI on Port Change Detect</i> bit (above) in this register is a one, the host controller will issue an SMI immediately.
SMI on Frame List Rollover Enable R/W	3	0b	When this bit is a one, and the <i>SMI on Frame List Rollover</i> bit (above) in this register is a one, the host controller will issue an SMI immediately.

USBLEGCTLSTS – RW - 32 bits - [PCI_Reg : EECF + 04h] (* Note)			
Field Name	Bits	Default	Description
SMI on Host System Error Enable	4	0b	When this bit is a one, and the <i>SMI on Host System Error</i> bit (above) in this register is a one, the host controller will issue an SMI immediately.
SMI on Async Advance Enable	5	0b	When this bit is a one, and the <i>SMI on Async Advance</i> bit (above) in this register is a one, the host controller will issue an SMI immediately.
Reserved.	12:6		These bits are reserved and must be set to zero.
SMI on OS Ownership Enable	13	0b	When this bit is a one AND the <i>OS Ownership Change</i> bit is one, the host controller will issue an SMI.
SMI on PCI Command Enable	14	0b	When this bit is one and <i>SMI on PCI Command</i> is one, then the host controller will issue an SMI.
SMI on BAR Enable	15	0b	When this bit is one and <i>SMI on BAR</i> is one, then the host controller will issue an SMI.
SMI on USB Complete	16	0b	Shadow bit of <i>USB Interrupt</i> (USBINT) bit in the USBSTS register. To set this bit to a zero, system software must write a one to the <i>USB Interrupt</i> bit in the USBSTS register. Read Only.
SMI on USB Error	17	0b	Shadow bit of <i>USB Error Interrupt</i> (USBERRINT) bit in the USBSTS register. To set this bit to a zero, system software must write a one to the <i>USB Error Interrupt</i> bit in the USBSTS register. Read Only.
SMI on Port Change Detect.	18	0b	Shadow bit of <i>Port Change Detect</i> bit in the USBSTS register. To set this bit to a zero, system software must write a one to the <i>Port Change Detect</i> bit in the USBSTS register. Read Only.
SMI on Frame List Rollover	19	0b	Shadow bit of <i>Frame List Rollover</i> bit in the USBSTS register. To set this bit to a zero, system software must write a one to the <i>Frame List Rollover</i> bit in the USBSTS register. Read Only.
SMI on Host System Error	20	0b	Shadow bit of <i>Host System Error</i> bit in the USBSTS register. To set this bit to a zero, system software must write a one to the <i>Host System Error</i> bit in the USBSTS register. Read Only.
SMI on Async Advance	21	0b	Shadow bit of the <i>Interrupt on Async Advance</i> bit in the USBSTS register. To set this bit to a zero, system software must write a one to the <i>Interrupt on Async Advance</i> bit in the USBSTS register. Read Only.
Reserved.	28:22		These bits are reserved and must be set to zero.
SMI on OS Ownership Change	29	0b	This bit is set to one whenever the <i>HC OS Owned Semaphore</i> bit in the USBLEGSUP register transitions from 1 to 0 or 0 to 1.
SMI on PCI Command	30	0b	This bit is set to one whenever the <i>PCI Command Register</i> is written.
SMI on BAR R/WC	31	0b	This bit is set to one whenever the <i>Base Address Register</i> (BAR) is written.
Note: EECF is defined in HCCPARAMS reg[15:8] (EHCI MEM x08) and is hard-wired to xA0.			

2.2.5 EHCI Memory Mapped Register

2.2.5.1 EHCI Capability Register

This block of registers is memory-mapped. Access address is equal to offset address plus base address defined in BAR[PCI_Reg : 10h].

Registers Name	Offset Address
Capability Register Length - CAPLENGTH	00h
Reserved	01h
Host Controller Interface Version – HCIVERSION	02h
Structural Parameters – HCSPARAMS	04h
Capability Parameters - HCCPARAMS	08h
Companion Port Route Description – HCSP-PORTROUTE	0Ch

CAPLENGTH – R - 8 bits - [MEM_Reg : 00h]
Description
This register is used as an offset to add to register base to find the beginning of the Operational Register Space. Default value = 20h.

HCIVERSION – R - 16 bits - [MEM_Reg : 02h]			
Field Name	Bits	Default	Description
HCIVERSION	15:0	0100h	This is a two-byte register containing a BCD encoding of the version number of interface to which this host controller interface conforms.

HCSPARAMS – R - 32 bits - [MEM_Reg : 04h]			
Field Name	Bits	Default	Description
N_PORTS	3:0	6h	This field specifies the number of physical downstream ports implemented on this host controller. The value of this field determines how many port registers are addressable in the Operational Register Space. Valid values are in the range of 1H to FH. A zero in this field is undefined.
Port Power Control (PPC)	4	0b	This field indicates whether the host controller implementation includes port power control. A one in this bit indicates the ports have port power switches. A zero in this bit indicates the port does not have port power switches. The value of this field affects the functionality of the Port Power field in each port status and control register.
Reserved	6:5		These bits are reserved and should be set to zero.
Port Routing Rules	7	0b	This field indicates the method used by this implementation for how all ports are mapped to companion controllers. The value of this field has the following interpretation: 0: The first N_PCC ports are routed to the lowest numbered function companion host controller, the next N_PCC port are routed to the next lowest function companion controller, and so on. 1: The port routing is explicitly enumerated by the first N_PORTS elements of the HCSP-PORTROUTE array.
Number of Ports per Companion Controller (N_PCC)	11:8	3h	This field indicates the number of ports supported per companion host controller. It is used to indicate the port routing configuration to system software. For example, if N_PORTS has a value of 6 and N_CC has a value of 2 then N_PCC could have a value of 3. The convention is that the first N_PCC ports are assumed to be routed to companion controller 1, the next N_PCC ports to companion controller 2, etc. In the previous example, the N_PCC could have been 4, where the first 4 are routed to companion controller 1 and the last two are routed to companion controller 2. The number in this field must be consistent with N_PORTS and N_CC.

HCSPARAMS – R - 32 bits - [MEM_Reg : 04h]			
Field Name	Bits	Default	Description
Number of Companion Controller (N_CC)	15:12	2h	This field indicates the number of companion controllers associated with this USB 2.0 host controller. A zero in this field indicates there are no companion host controllers. Port-ownership hand-off is not supported. Only high-speed devices are supported on the host controller root ports. A value larger than zero in this field indicates there are companion USB 1.1 host controller(s). Port-ownership hand-offs are supported. High, Full- and Low-speed devices are supported on the host controller root ports.
Port Indicators (P_INDICATOR)	16	0b	This bit indicates whether the ports support port indicator control. When this bit is a one, the port status and control registers include a read/writeable field for controlling the state of the port indicator.
Reserved	19:17		These bits are reserved and should be set to zero.
Debug Port Number	23:20	1h	Optional. This register identifies which of the host controller ports is the debug port. The value is the port number (one-based) of the debug port. A non-zero value in this field indicates the presence of a debug port. The value in this register must not be greater than N_PORTS.
Reserved	31:24		These bits are reserved and should be set to zero.

HCCPARAMS – R - 32 bits - [MEM_Reg : 08h]			
Field Name	Bits	Default	Description
64-bit Addressing Capability	0	0b	This field documents the addressing range capability of this implementation. 0: Data structures using 32-bit address memory pointers 1: Data structures using 64-bit address memory pointers
Programmable Frame List Flag	1	1b	If this bit is set to a zero, then system software must use a frame list length of 1024 elements with this host controller. The USBCMD register <i>Frame List Size</i> field is a read-only register and should be set to zero. If set to a one, then system software can specify and use a smaller frame list and configure the host controller via the USBCMD register <i>Frame List Size</i> field. The frame list must always be aligned on a 4K page boundary. This requirement ensures that the frame list is always physically contiguous.
Asynchronous Schedule Park Capability	2	1b	If this bit is set to a one, then the host controller supports the park feature for high-speed queue heads in the Asynchronous Schedule. The feature can be disabled or enabled and set to a specific level by using the <i>Asynchronous Schedule Park Mode Enable</i> and <i>Asynchronous Schedule Park Mode Count</i> fields in the USBCMD register.
Reserved	3		These bits are reserved and should be set to zero.
Isochronous Scheduling Threshold	7:4	1h	This field indicates, relative to the current position of the executing host controller, where software can reliably update the isochronous schedule. When bit [7] is zero, the value of the least significant 3 bits indicates the number of micro-frames a host controller can hold a set of isochronous data structures (one or more) before flushing the state. When bit [7] is a one, then host software assumes the host controller may cache an isochronous data structure for an entire frame.
EHCI Extended Capabilities Pointer (EECP)	15:8	A0h	This optional field indicates the existence of a capabilities list. A value of 00h indicates no extended capabilities are implemented. A non-zero value in this register indicates the offset in PCI configuration space of the first EHCI extended capability. The pointer value must be 40h or greater if implemented to maintain the consistency of the PCI header defined for this class of device.
Reserved	31:16		These bits are reserved and should be set to zero.

HCSP-PORTROUTE – R - 60 bits - [MEM_Reg : 0Ch]	
Description	
This optional field is valid only if <i>Port Routing Rules</i> field in the HCCPARAMS register is set to a one. This field is a 15-element nibble array (each 4 bits is one array element). Each array location corresponds one-to-one with a physical port provided by the host controller.	

2.2.5.2 EHCI Operational Register

EHCI Memory Map Registers: Host Controller Operational Registers (EHCI_EOR 0x00 ~ 0xCC)

This block of registers is memory-mapped. The base offset, EHCI_EOR, is defined in CAPLENGTH register (MEM_Reg: 00h, default value = 20h).

Registers Name	Offset Address
USB Command – USBCMD	EHCI_EOR + 00h
USB Satus – USBSTS	EHCI_EOR + 04h
USB Interrupt Enable – USBINTR	EHCI_EOR + 08h
USB Frame Index – FRINDEX	EHCI_EOR + 0Ch
4G Segment Selector – CTRLDSSEGMENT	EHCI_EOR + 10h
Frame List Base Address – PERIODICLISTBASE	EHCI_EOR + 14h
Next Asynchronous List Address – ASYNCLISTADDR	EHCI_EOR + 18h
Reserved	EHCI_EOR + (1Ch~3Fh)
Configured Flag – CONFIGFLAG	EHCI_EOR + 40h
Port Status/Control – PORTSC (1-N_PORTS)	EHCI_EOR + (44h~68h)
DebugPort MISC Control	EHCI_EOR + 80h
Packet Buffer Threshold Values	EHCI_EOR + 84h
USB PHY Status 0	EHCI_EOR + 88h
USB PHY Status 1	EHCI_EOR + 8Ch
USB PHY Status 2	EHCI_EOR + 90h
UTMI Control	EHCI_EOR + 94h
Bist Control / Loopback Test	EHCI_EOR + 98h
EOR MISC Control	EHCI_EOR + 9Ch
USB Phy Calibration	EHCI_EOR + A0h
USB Common PHY Control	EHCI_EOR + A4h
USB Debug Port	0E0h~0F0h (* Note)

Note: The base offset of Debug Port registers is defined directly in DEBUG_PRT Control register (EHCI_PCI_CFG xE4[28:16]), regardless of the value in CAPLENGTH register (MEM_Reg: 00h) so range is equivalent to EHCI_EOR + (C0h~D0h).

USBCMD – RW - 32 bits - [EOR_Reg : EHCI_EOR + 00h]			
Field Name	Bits	Default	Description
Run/Stop (RS)	0	0b	1: Run 0: Stop. When set to a 1, the Host Controller proceeds with execution of the schedule. The Host Controller continues execution as long as this bit is set to a 1. When this bit is set to 0, the Host Controller completes the current and any actively pipelined transactions on the USB and then halts. The Host Controller must halt within 16 micro-frames after software clears the Run bit. The HC Halted bit in the status register indicates when the Host Controller has finished its pending pipelined transactions and has entered the stopped state. Software must not write a one to this field unless the host controller is in the Halted state (i.e. <i>Halted</i> in the USBSTS register is a one). Doing so will yield undefined results.

USBCMD – RW - 32 bits - [EOR_Reg : EHCI_EOR + 00h]			
Field Name	Bits	Default	Description
Host Controller Reset (HCRESET)	1	0b	This control bit is used by software to reset the host controller. The effects of this on Root Hub registers are similar to a Chip Hardware Reset. When software writes a one to this bit, the Host Controller resets its internal pipelines, timers, counters, state machines, etc. to their initial value. Any transaction currently in progress on USB is immediately terminated. A USB reset is not driven on downstream ports. PCI Configuration registers are not affected by this reset. All operational registers, including port registers and port state machines are set to their initial values. Port ownership reverts to the companion host controller(s). Software must reinitialize the host controller in order to return the host controller to an operational state. This bit is set to zero by the Host Controller when the reset process is complete. Software cannot terminate the reset process early by writing a zero to this register. Software should not set this bit to a one when the <i>HCHalted</i> bit in the USBSTS register is a zero. Attempting to reset an actively running host controller will result in undefined behavior.
Frame List Size	3:2	00b	This field is R/W only if <i>Programmable Frame List Flag</i> in the HCCPARAMS registers is set to a one. This field specifies the size of the frame list. The size the frame list controls which bits in the Frame Index Register should be used for the Frame List Current index. Values mean: 00b: 1024 elements (4096 bytes) Default value 01b: 512 elements (2048 bytes) 10b: 256 elements (1024 bytes) For resource-constrained environments 11b: Reserved [Read/Write or Read-only]
Periodic Schedule Enable	4	0b	This bit controls whether the host controller skips processing the Periodic Schedule. 0: Do not process the Periodic Schedule 1: Use the PERIODICLISTBASE register to access the Periodic Schedule.
Asynchronous Schedule Enable	5	0b	This bit controls whether the host controller skips processing the Asynchronous Schedule. 0b: Do not process the Asynchronous Schedule 1b: Use the ASYNCLISTADDR register to access the Asynchronous Schedule.
Interrupt on Async Advance Doorbell	6	0b	This bit is used as a doorbell by software to tell the host controller to issue an interrupt the next time it advances asynchronous schedule. Software must write a 1 to this bit to <i>ring</i> the doorbell. When the host controller has evicted all appropriate cached schedule state, it sets the <i>Interrupt on Async Advance</i> status bit in the USBSTS register. If the <i>Interrupt on Async Advance Enable</i> bit in the USBINTR register is a one then the host controller will assert an interrupt at the next interrupt threshold. The host controller sets this bit to a zero after it has set the <i>Interrupt on Async Advance</i> status bit in the USBSTS register to a one. Software should not write a one to this bit when the asynchronous schedule is disabled. Doing so will yield undefined results.
Light Host Controller Reset (Optional)	7	0b	This control bit is not required. If implemented, it allows the driver to reset the EHCI controller without affecting the state of the ports or the relationship to the companion host controllers. For example, the PORSTC registers should not be reset to their default values and the CF bit setting should not go to zero (retaining port ownership relationships). A host software read of this bit as zero indicates the Light Host Controller Reset has completed and it is safe for host software to re-initialize the host controller. A host software read of this bit as a one indicates the Light Host Controller Reset has not yet completed. If not implemented a read of this field will always return a zero.

USBCMD – RW - 32 bits - [EOR_Reg : EHCI_EOR + 00h]			
Field Name	Bits	Default	Description
Asynchronous Schedule Park Mode Count (Optional)	9:8	11b	If the <i>Asynchronous Park Capability</i> bit in the HCCPARAMS register is a one, then this field defaults to 3h and is R/W. Otherwise it defaults to zero and is RO. It contains a count of the number of successive transactions the host controller is allowed to execute from a high-speed queue head on the Asynchronous schedule before continuing traversal of the Asynchronous schedule. Valid values are 1h to 3h. Software must not write a zero to this bit when <i>Park Mode Enable</i> is a one as this will result in undefined behavior. [Read/Write or Read-only]
Reserved	10		This bit is reserved and should be set to Zero.
Asynchronous Schedule Park Mode Enable (Optional)	11	1b	If the <i>Asynchronous Park Capability</i> bit in the HCCPARAMS register is a one, then this bit defaults to a 1h and is R/W. Otherwise the bit must be a zero and is RO. Software uses this bit to enable or disable Park mode. When this bit is one, Park mode is enabled. When this bit is a zero, Park mode is disabled. [Read/Write or Read-only]
Reserved	15:12		This bit is reserved and should be set to Zero.
Interrupt Threshold Control	23:16	08h	This field is used by system software to select the maximum rate at which the host controller will issue interrupts. The only valid values are defined below. If software writes an invalid value to this register, the results are undefined. 00h: Reserved 01h: 1 micro-frame 02h: 2 micro-frames 04h: 4 micro-frames 08h: 8 micro-frames (default, equates to 1 ms) 10h: 16 micro-frames (2 ms) 20h: 32 micro-frames (4 ms) 40h: 64 micro-frames (8 ms) Any other value in this register yields undefined results. Software modifications to this bit while HCHalted bit is equal to zero results in undefined behavior.
Reserved	31:24		These bits are reserved and should be set to Zeros.

USBSTS - RW - 32 bits - [EOR_Reg : EHCI_EOR + 04h]			
Field Name	Bits	Default	Description
USBINT	0	0b	USB Interrupt. The Host Controller sets this bit to 1 on the completion of a USB transaction, which results in the retirement of a Transfer Descriptor that had its IOC bit set. The Host Controller also sets this bit to 1 when a short packet is detected (actual number of bytes received was less than the expected number of bytes).
USBERRINT	1	0b	USB Error Interrupt . The Host Controller sets this bit to 1 when completion of a USB transaction results in an error condition (e.g., error counter underflow). If the TD on which the error interrupt occurred also had its IOC bit set, both this bit and <i>USBINT</i> bit are set.

USBSTS - RW - 32 bits - [EOR_Reg : EHCI_EOR + 04h]			
Field Name	Bits	Default	Description
Port Change Detect	2	0b	Port Change Detect. The Host Controller sets this bit to a one when any port for which the <i>Port Owner</i> bit is set to zero (see Section 2.3.9) has a change bit transition from a zero to a one or a Force Port Resume bit transition from a zero to a one as a result of a J-K transition detected on a suspended port. This bit will also be set as a result of the Connect Status Change being set to a one after system software has relinquished ownership of a connected port by writing a zero to a port's <i>Port Owner</i> bit. This bit is allowed to be maintained in the Auxiliary power well. Alternatively, it is also acceptable that on a D3 to D0 transition of the EHCI HC device, this bit is loaded with the OR of all of the PORTSC change bits (including: Force port resume, over-current change, enable/disable change and connect status change).
Frame List Rollover	3	0b	Frame List Rollover. The Host Controller sets this bit to a one when the Frame List Index rolls over from its maximum value to zero. The exact value at which the rollover occurs depends on the frame list size. For example, if the frame list size (as programmed in the Frame List Size field of the USBCMD register) is 1024, the Frame Index Register rolls over every time FRINDEX[13] toggles. Similarly, if the size is 512, the Host Controller sets this bit to a one every time FRINDEX[12] toggles.
Host System Error	4	0b	Host System Error. The Host Controller sets this bit to 1 when a serious error occurs during a host system access involving the Host Controller module. In a PCI system, conditions that set this bit to 1 include PCI Parity error, PCI Master Abort, and PCI Target Abort. When this error occurs, the Host Controller clears the Run/Stop bit in the Command register to prevent further execution of the scheduled TDs.
Interrupt on Async Advance	5	0b	Interrupt on Async Advance. System software can force the host controller to issue an interrupt the next time the host controller advances the asynchronous schedule by writing a one to the <i>Interrupt on Async Advance Doorbell</i> bit in the USBCMD register. This status bit indicates the assertion of that interrupt source.
Reserved	11:6		These bits are reserved and should be set to zero.
HCHalted	12	1b	HCHalted. This bit is a zero whenever the <i>Run/Stop</i> bit is a one. The Host Controller sets this bit to one after it has stopped executing as a result of the Run/Stop bit being set to 0, either by software or by the Host Controller hardware (e.g. internal error). [Read-only]
Reclamation	13	0b	Reclamation. This is a read-only status bit, which is used to detect an empty asynchronous schedule. [Read-only]
Periodic Schedule Status	14	0b	Periodic Schedule Status. The bit reports the current real status of the Periodic Schedule. If this bit is a zero then the status of the Periodic Schedule is disabled. If this bit is a one then the status of the Periodic Schedule is enabled. The Host Controller is not required to immediately disable or enable the Periodic Schedule when software transitions the Periodic Schedule Enable bit in the USBCMD register. When this bit and the Periodic Schedule Enable bit are the same value, the Periodic Schedule is either enabled (1) or disabled (0). [Read-only]
Asynchronous Schedule Status	15	0b	Asynchronous Schedule Status. The bit reports the current real status of the Asynchronous Schedule. If this bit is a zero then the status of the Asynchronous Schedule is disabled. If this bit is a one then the status of the Asynchronous Schedule is enabled. The Host Controller is not required to immediately disable or enable the Asynchronous Schedule when software transitions the <i>Asynchronous Schedule Enable</i> bit in the USBCMD register. When this bit and the <i>Asynchronous Schedule Enable</i> bit are the same value, the Asynchronous Schedule is either enabled (1) or disabled (0). [Read-only]
Reserved	31:16		These bits are reserved and should be set to zero.

USBINTR –RW - 32 bits - [EOR_Reg : EHCI_EOR + 08h]			
Field Name	Bits	Default	Description
USB Interrupt Enable	0	0b	When this bit is a one, and the <i>USBINT</i> bit in the USBSTS register is a one, the host controller will issue an interrupt at the next interrupt threshold. The interrupt is acknowledged by software clearing the <i>USBINT</i> bit.
USB Error Interrupt Enable	1	0b	When this bit is a one, and the <i>USBERRINT</i> bit in the USBSTS register is a one, the host controller will issue an interrupt at the next interrupt threshold. The interrupt is acknowledged by software clearing the <i>USBERRINT</i> bit.
Port Change Interrupt Enable	2	0b	When this bit is a one, and the <i>Port Change Detect</i> bit in the USBSTS register is a one, the host controller will issue an interrupt. The interrupt is acknowledged by software clearing the <i>Port Change Detect</i> bit.
Frame List Rollover Enable	3	0b	When this bit is a one, and the <i>Frame List Rollover</i> bit in the USBSTS register is a one, the host controller will issue an interrupt. The interrupt is acknowledged by software clearing the <i>Frame List Rollover</i> bit.
Host System Error Enable	4	0b	When this bit is a one, and the <i>Host System Error Status</i> bit in the USBSTS register is a one, the host controller will issue an interrupt. The interrupt is acknowledged by software clearing the <i>Host System Error</i> bit.
Interrupt on Async Advance Enable	5	0b	When this bit is a one, and the <i>Interrupt on Async Advance</i> bit in the USBSTS register is a one, the host controller will issue an interrupt at the next interrupt threshold. The interrupt is acknowledged by software clearing the <i>Interrupt on Async Advance</i> bit.
Reserved	31:6		These bits are reserved and should be zero

FRINDEX –RW - 32 bits - [EOR_Reg : EHCI_EOR + 0Ch]			
Field Name	Bits	Default	Description
Frame Index	13:0	0h	When this bit is a one, and the <i>Interrupt on Async Advance</i> bit in the USBSTS register is a one, the host controller will issue an interrupt at the next interrupt threshold. The interrupt is acknowledged by software clearing the <i>Interrupt on Async Advance</i> bit.
Reserved	31:14		These bits are reserved and should be zero

CTRLDSSEGMENT –RW - 32 bits - [EOR_Reg : EHCI_EOR + 10h]			
Field Name	Bits	Default	Description
CTRLDSSEGMENT	31:0	0h	This 32-bit register corresponds to the most significant address bits [63:32] for all EHCI data structures. If the <i>64-bit Addressing Capability</i> field in HCCPARAMS is a zero, then this register is not used. Software cannot write to it and a read from this register will return zeros. If the <i>64-bit Addressing Capability</i> field in HCCPARAMS is a one, then this register is used with the link pointers to construct 64-bit addresses to EHCI control data structures. This register is concatenated with the link pointer from either the <i>PERIODICLISTBASE</i> , <i>ASYNCLISTADDR</i> , or any control data structure link field to construct a 64-bit address. This register allows the host software to locate all control data structures within the same 4 Gigabyte memory segment.

PERIODICLISTBASE –RW - 32 bits - [EOR_Reg : EHCI_EOR + 14h]			
Field Name	Bits	Default	Description
Reserved	11:0		These bits are reserved. Must be written as 0s. During runtime, the values of these bits are undefined.
Base Address	31:12	000h	These bits correspond to memory address signals [31:12], respectively.

ASYNCLISTADDR –RW - 32 bits - [EOR_Reg : EHCI_EOR + 18h]			
Field Name	Bits	Default	Description
Reserved	4:0		These bits are reserved and their value has no effect on operation.
Link Pointer Low (LPL)	31:5	00h	These bits correspond to memory address signals [31:5], respectively. This field may only reference a Queue Head (QH).

CONFIGFLAG –RW - 32 bits - [EOR_Reg : EHCI_EOR + 40h]			
Field Name	Bits	Default	Description
Configure Flag (CF)	0	0b	Host software sets this bit as the last action in its process of configuring the Host Controller. This bit controls the default port-routing control logic. Bit values and side-effects are listed below: 0b: Port routing control logic default-routes each port to an implementation dependent classic host controller. 1b: Port routing control logic default-routes all ports to this host controller.
Reserved	31:1		These bits are reserved and should be set to zero.

PORTSC (1-N_PORTS) –RW - 32 bits - [EOR_Reg : EHCI_EOR + (44h-58h)]			
Field Name	Bits	Default	Description
Current Connect Status	0	0b	1: Device is present on port. 0: No device is present. This value reflects the current state of the port, and may not correspond directly to the event that caused the Connect Status Change bit (Bit 1) to be set. This field is zero if <i>Port Power</i> is zero. [Read-only]
Connect Status Change	1	0b	1: Change in Current Connect Status. 0: No change. Indicates a change has occurred in the port's Current Connect Status. The host controller sets this bit for all changes to the port device connect status, even if system software has not cleared an existing connect status change. For example, the insertion status changes twice before system software has cleared the changed condition, hub hardware will be "setting" an already-set bit (i.e., the bit will remain set). Software sets this bit to 0 by writing a 1 to it. This field is zero if <i>Port Power</i> is zero.
Port Enabled/Disabled	2	0b	1: Enable. 0: Disable Ports can only be enabled by the host controller as a part of the reset and enable. Software cannot enable a port by writing a one to this field. The host controller will only set this bit to a one when the reset sequence determines that the attached device is a high-speed device. Ports can be disabled by either a fault condition (disconnect event or other fault condition) or by host software. Note that the bit status does not change until the port state actually changes. There may be a delay in disabling or enabling a port due to other host controller and bus events. When the port is disabled (0b) downstream propagation of data is blocked on this port, except for reset. This field is zero if <i>Port Power</i> is zero.
Port Enable/Disable Change	3	0b	1: Port enabled/disabled status has changed. 0: No change. For the root hub, this bit gets set to a one only when a port is disabled due to the appropriate conditions existing at the EOF2. Software clears this bit by writing a 1 to it. This field is zero if <i>Port Power</i> is zero.
Over-current Active	4	0b	1: This port currently has an over-current condition. 0: This port does not have an over-current condition. This bit will automatically transition from a one to a zero when the over current condition is removed.
Force Port Resume	6	0b	1: Resume detected/driven on port. 0: No resume (K-state) detected/driven on port. This functionality defined for manipulating this bit depends on the value of the <i>Suspend</i> bit. For example, if the port is not suspended (<i>Suspend</i> and <i>Enabled</i> bits are a one) and software transitions this bit to a one, then the effects on the bus are undefined. Software sets this bit to a 1 to drive resume signaling. The Host Controller sets this bit to a 1 if a J-to-K transition is detected while the port is in the Suspend state. When this bit transitions to a one because a J-to-K transition is detected, the <i>Port Change Detect</i> bit in the USBSTS register is also set to a one. If software sets this bit to a one, the host controller must not set the <i>Port Change Detect</i> bit. Note that when the EHCI controller owns the port, the resume sequence follows the defined sequence documented in the USB Specification Revision 2.0. The resume signaling (Full-speed 'K') is driven on the port as long as this bit remains a one. Software must appropriately time the Resume and set this bit to a zero when the appropriate amount of time has elapsed. Writing a zero (from one) causes the port to return to high-speed mode (forcing the bus below the port into a high-speed idle). This bit will remain a one until the port has switched to the high-speed idle. The host controller must complete this transition within 2 milliseconds of software setting this bit to a zero. This field is zero if <i>Port Power</i> is zero.

PORTSC (1-N_PORTS) –RW - 32 bits - [EOR_Reg : EHCI_EOR + (44h–58h)]											
Field Name	Bits	Default	Description								
Suspend	7	0b	<p>1: Port in suspend state. 0: Port not in suspend state.</p> <p>Port Enabled Bit and Suspend bit of this register define the port states as follows:</p> <table border="0"> <tr> <td>Bits [Port Enabled, Suspend]</td> <td>Port State</td> </tr> <tr> <td>0X</td> <td>Disable</td> </tr> <tr> <td>10</td> <td>Enable</td> </tr> <tr> <td>11</td> <td>Suspend</td> </tr> </table> <p>When in suspend state, downstream propagation of data is blocked on this port, except for port reset. The blocking occurs at the end of the current transaction, if a transaction was in progress when this bit was written to 1. In the suspend state, the port is sensitive to resume detection. Note that the bit status does not change until the port is suspended and that there may be a delay in suspending a port if there is a transaction currently in progress on the USB. A write of zero to this bit is ignored by the host controller. The host controller will unconditionally set this bit to a zero when:</p> <ul style="list-style-type: none"> - Software sets the <i>Force Port Resume</i> bit to a zero (from a one). - Software sets the <i>Port Reset</i> bit to a one (from a zero). <p>If host software sets this bit to a one when the port is not enabled (i.e. Port enabled bit is a zero) the results are undefined. This field is zero if <i>Port Power</i> is zero.</p>	Bits [Port Enabled, Suspend]	Port State	0X	Disable	10	Enable	11	Suspend
Bits [Port Enabled, Suspend]	Port State										
0X	Disable										
10	Enable										
11	Suspend										
Port Reset	8	0b	<p>1: Port is in Reset. 0: Port is not in Reset.</p> <p>When software writes a one to this bit (from a zero), the bus reset sequence as defined in the USB Specification Revision 2.0 is started. Software writes a zero to this bit to terminate the bus reset sequence. Software must keep this bit at a one long enough to ensure the reset sequence, as specified in the USB Specification Revision 2.0, completes. Note: when software writes this bit to a one, it must also write a zero to the <i>Port Enable</i> bit.</p> <p>Note: When software writes a zero to this bit there may be a delay before the bit status changes to a zero. The bit status will not read as a zero until after the reset has completed. If the port is in high-speed mode after reset is complete, the host controller will automatically enable this port (e.g. set the <i>Port Enable</i> bit to a one). A host controller must terminate the reset and stabilize the state of the port within 2 milliseconds of software transitioning this bit from a one to a zero. For example: if the port detects that the attached device is high-speed during reset, then the host controller must have the port in the enabled state within 2ms of software writing this bit to a zero.</p> <p>The <i>HCHalted</i> bit in the USBSTS register should be a zero before software attempts to use this bit. The host controller may hold Port Reset asserted to a one when the <i>HCHalted</i> bit is a one. This field is zero if <i>Port Power</i> is zero.</p>								
Reserved	9		This bit is reserved for future use, and should return a value of zero when read.								

PORTSC (1-N_PORTS) –RW - 32 bits - [EOR_Reg : EHCI_EOR + (44h–58h)]																		
Field Name	Bits	Default	Description															
Line Status	11:10		<p>These bits reflect the current logical levels of the D+ (bit 11) and D- (bit [10]) signal lines. These bits are used for detection of low-speed USB devices prior to the port reset and enable sequence. This field is valid only when the port enable bit is zero and the current connect status bit is set to a one.</p> <p>The encoding of the bits are:</p> <table border="0"> <tr> <td>Bits [11:10]</td> <td>USB State</td> <td>Interpretation</td> </tr> <tr> <td>00b</td> <td>SE0</td> <td>Not Low-speed device, perform EHCI reset</td> </tr> <tr> <td>10b</td> <td>J-state</td> <td>Not Low-speed device, perform EHCI reset</td> </tr> <tr> <td>01b</td> <td>K-state</td> <td>Low-speed device, release ownership of port</td> </tr> <tr> <td>11b</td> <td>Undefined</td> <td>Not Low-speed device, perform EHCI reset.</td> </tr> </table> <p>This value of this field is undefined if <i>Port Power</i> is zero. [Read-only]</p>	Bits [11:10]	USB State	Interpretation	00b	SE0	Not Low-speed device, perform EHCI reset	10b	J-state	Not Low-speed device, perform EHCI reset	01b	K-state	Low-speed device, release ownership of port	11b	Undefined	Not Low-speed device, perform EHCI reset.
Bits [11:10]	USB State	Interpretation																
00b	SE0	Not Low-speed device, perform EHCI reset																
10b	J-state	Not Low-speed device, perform EHCI reset																
01b	K-state	Low-speed device, release ownership of port																
11b	Undefined	Not Low-speed device, perform EHCI reset.																
Port Power	12		<p>The function of this bit depends on the value of the <i>Port Power Control (PPC)</i> field in the HCSPARAMS register. The behavior is as follows:</p> <table border="0"> <tr> <td>PPC</td> <td>PP</td> <td>Operation</td> </tr> <tr> <td>0b</td> <td>1b</td> <td>RO: Host controller does not have port power control switches. Each port is hard-wired to power.</td> </tr> <tr> <td>1b</td> <td>1b/0b</td> <td>RW: Host controller has port power control switches. This bit represents the current setting of the switch (0: Off, 1: On). When power is not available on a port (i.e. <i>PP</i> equals a 0), the port is non-functional and will not report attaches, detaches, etc.</td> </tr> </table> <p>When an over-current condition is detected on a powered port and <i>PPC</i> is a one, the <i>PP</i> bit in each affected port may be transitioned by the host controller from a 1 to 0 (removing power from the port). [Read-write or Read-only]</p>	PPC	PP	Operation	0b	1b	RO: Host controller does not have port power control switches. Each port is hard-wired to power.	1b	1b/0b	RW: Host controller has port power control switches. This bit represents the current setting of the switch (0: Off, 1: On). When power is not available on a port (i.e. <i>PP</i> equals a 0), the port is non-functional and will not report attaches, detaches, etc.						
PPC	PP	Operation																
0b	1b	RO: Host controller does not have port power control switches. Each port is hard-wired to power.																
1b	1b/0b	RW: Host controller has port power control switches. This bit represents the current setting of the switch (0: Off, 1: On). When power is not available on a port (i.e. <i>PP</i> equals a 0), the port is non-functional and will not report attaches, detaches, etc.																
Port Owner	13	1b	<p>This bit unconditionally goes to a 0b when the <i>Configured</i> bit in the CONFIGFLAG register makes a 0b to 1b transition. This bit unconditionally goes to 1b whenever the <i>Configured</i> bit is zero. System software uses this field to release ownership of the port to a selected host controller (in the event that the attached device is not a high-speed device). Software writes a one to this bit when the attached device is not a high-speed device. A one in this bit means that a companion host controller owns and controls the port.</p>															
Port Indicator Control	15:14	00b	<p>Writing to this bit has no effect if the <i>P_INDICATOR</i> bit in the HCSPARAMS register is a zero. If <i>P_INDICATOR</i> bit is a one, then the bit encodings are:</p> <table border="0"> <tr> <td>Bit Value</td> <td>Meaning</td> </tr> <tr> <td>00b</td> <td>Port indicators are off</td> </tr> <tr> <td>01b</td> <td>Amber</td> </tr> <tr> <td>10b</td> <td>Green</td> </tr> <tr> <td>11b</td> <td>Undefined</td> </tr> </table> <p>Refer to the USB Specification Revision 2.0 for a description on how these bits are to be used. This field is zero if <i>Port Power</i> is zero.</p>	Bit Value	Meaning	00b	Port indicators are off	01b	Amber	10b	Green	11b	Undefined					
Bit Value	Meaning																	
00b	Port indicators are off																	
01b	Amber																	
10b	Green																	
11b	Undefined																	
Port Test Control	19:16	0000b	<p>When this field is zero, the port is NOT operating in a test mode. A non-zero value indicates that it is operating in test mode and the specific test mode is indicated by the specific value. The encoding of the test mode bits are (0110b - 1111b are reserved):</p> <table border="0"> <tr> <td>Bits</td> <td>Test Mode</td> </tr> <tr> <td>0000b</td> <td>Test mode not enabled</td> </tr> <tr> <td>0001b</td> <td>Test J_STATE</td> </tr> <tr> <td>0010b</td> <td>Test K_STATE</td> </tr> <tr> <td>0011b</td> <td>Test SE0_NAK</td> </tr> <tr> <td>0100b</td> <td>Test Packet</td> </tr> <tr> <td>0101b</td> <td>Test FORCE_ENABLE</td> </tr> </table>	Bits	Test Mode	0000b	Test mode not enabled	0001b	Test J_STATE	0010b	Test K_STATE	0011b	Test SE0_NAK	0100b	Test Packet	0101b	Test FORCE_ENABLE	
Bits	Test Mode																	
0000b	Test mode not enabled																	
0001b	Test J_STATE																	
0010b	Test K_STATE																	
0011b	Test SE0_NAK																	
0100b	Test Packet																	
0101b	Test FORCE_ENABLE																	
Wake on Connect Enable	20	0	<p>Writing this bit to a one enables the port to be sensitive to device connects as wake-up events. This field is zero if <i>Port Power</i> is zero.</p>															

PORTSC (1-N_PORTS) –RW - 32 bits - [EOR_Reg : EHCI_EOR + (44h~58h)]			
Field Name	Bits	Default	Description
Wake on Disconnect Enable	21	0b	Writing this bit to a one enables the port to be sensitive to device disconnects as wake-up events. This field is zero if <i>Port Power</i> is zero.
Wake on Over-current Enable	22	0b	Writing this bit to a one enables the port to be sensitive to over-current conditions as wake-up events. This field is zero if <i>Port Power</i> is zero.
Reserved	31:23		Reserved

DebugPort MISC Control – RW - 32 bits - [EOR_Reg: EHCI_EOR + 80h]			
Field Name	Bits	Default	Description
Enable Scale Down Frame Base time	0	0h	Enables the Frame Base time to be scaled down for simulation.
Frame Base Value	13:1	000h	Frame base counter, use for simulation only.
Reserved	22:14		Reserved
Debug Port allow force port owner bit in PORTSC of DBP	23	1'b0	
Debug Port SYNC packet generation source	24	0b	0: SYNC packet generated by asserting one cycle pulse txvalid to PHY 1: SYNC packet generated by sending dummy packet (reserved PID).
Debug Port SYNC packet generation time gap	26:25	11b	00: 125 usec 01: 250 usec 10: 500 usec 11: 1 msec
Enable Debug Port Number Re-mapping	27	0h	Set the bit to enable the Debug Port route to any port. The default is route to 1 st port (port-0), but can be re-map to other port when this bit is set. The mapping is controlled by [31:28].
Debug Port Number Re-mapping	31:28	1h	This is the back door register to re-map the debug port traffic to other port. The value in HCSPARAMS[23:20] will be controlled by this register if the enable bit ([27]) is set. When these bits are set to 0h, debug port is totally disabled.

Packet Buffer Threshold Values – RW - 32 bits - [EOR_Reg : EHCI_EOR + 84h]			
Field Name	Bits	Default	Description
IN Threshold	7:0	10h	The PCI transaction starts when threshold of internal FIFO for receive packet is reached. The value represents multiple of 8 bytes – 10h means 128 bytes. The smallest acceptable value is 08h (64 bytes).
Reserved	15:8		Reserved
OUT Threshold	23:16	20h	The transmit packet starts at UTMI interface when threshold of internal FIFO for transmit packet is reached. The value represents multiple of 8 bytes – 10h means 128 bytes. The smallest acceptable value is 08h (64 bytes).
Reserved	31:24		Reserved

USB PHY Status 0 – RW - 32 bits - [EOR_Reg: EHCI_EOR + 88h]			
Field Name	Bits	Default	Description
PORT0_PHYStatus	7:0	00h	Read only. PHY Status of Port0
PORT1_PHYStatus	15:8	00h	Read only. PHY Status of Port1
PORT2_PHYStatus	23:16	00h	Read only. PHY Status of Port2
PORT3_PHYStatus	31:24	00h	Read only. PHY Status of Port3
*Note: Use the VControlModeSel (UTMI_Control register[7]) to select which group of status should be read back.			

USB PHY Status 1 – RW - 32 bits - [EOR_Reg: EHCI_EOR + 8Ch]			
Field Name	Bits	Default	Description
PORT4_PHYStatus	7:0	00h	Read only. PHY Status of Port4
PORT5_PHYStatus	15:8	00h	Read only. PHY Status of Port5
Reserved	31:16	0000h	Reserved

UTMI Control – RW - 32 bits - [EOR_Reg: EHCI_EOR + 94h]			
Field Name	Bits	Default	Description
VControl	6:0	0h	Control PHY setting Group-0 (VControlModeSel=0) VControl[6:0] = { CLKOff_disable, DUTYADJ[2:0], HSADJ[2:0]} - HSADJ : HS TX current adjustment. 000 : -10% 001 : -5% 100 : 0% 101 : + 5% 110 : + 10% 111 : + 15% - DUTYADJ: Adjust clk480 (in analog PHY) duty cycle from range 40-60% to 60-40%. - CLKOFF_disable : Disables UTMICLK gate off function Group-1 (VControlModeSel =1) VControl[6:0] = {Reserved, TESTMODE[3:0]}
VControlModeSel	7	0b	The PHY control modes are divided into 2 groups. VcontrolModeSel is used to select the group.
Reserved	11:8		Reserved
VLoadB	12	1b	Update PHY control mode (active load) 0: Load the new VControl value to PHY/common block 1: Only VControlModeSel value to PHY will be updated for selecting different PHY status group (see PHY status registers, EOR_Reg x88 ~ x90). But VControl[6:0] value inside PHY won't get affected.
Port Number	16:13	0h	Select the corresponding port PHY or common block to load the VControl bits. 0000: port0 0001: port1 0010: port2 0101: port5 0111 ~ 1110: Reserved , no effect 1111: Common block
VBusy	17	0b	RO. To block software write to [16:8] when port router is updating the field.
Reserved	31:18		Reserved

BIST Control / Loopback Test – RW - 32 bits - [EOR_Reg : EHCI_EOR + 98h]			
Field Name	Bits	Default	Description
Received packet count	3:0	0h	RX data packet count. This counter defines the number (in power of 16) of RX data packet should be checked for the loop back test.
Reserved	7:4		Reserved
Enable Loop Back test	8	0b	Enables external USB Port Loop back test. The Loop Back test is to set one port to TX mode (Test Packet mode) and one port in RX mode (Test SE0_NAK). Please reference to PORTSCx[19:16] control the port into TX or RX mode.

BIST Control / Loopback Test – RW - 32 bits - [EOR_Reg : EHCI_EOR + 98h]			
Field Name	Bits	Default	Description
Loopback Test Status	9	0b	Read Only. Loop back status. 0: CRC Error on Loop Back Receiving Data 1: Good CRC on Loop Back Receiving data
Loopback Test Done	10	0b	Read Only. Indicate Loop back test done.
Reserved	31:11	0h	

EOR MISC Control – RW - 32 bits - [EOR_Reg : EHCI_EOR + 9Ch]			
Field Name	Bits	Default	Description
Reserved	11:0	0h	Reserved
EHCI Power Saving Enable	12	1b	Enables power saving clock gating. When enable, dynamic clock gating is enable when EHCI is not at operational mode. Clock goes to all memory module will be gated off, Blink clock also got gated off unless the connection interrupt is detected.
Reserved	31:13	0h	Reserved

USB Common PHY CAL & Control Register – RW - 32 bits - [EOR_Reg: EHCI_EOR + A0h]			
Field Name	Bits	Default	Description
ComCalBus	6:0		Default value = don't care. Read only. Calibration bus value from PHY before adjustment.
Reserved	7	0b	Reserved
NewCalBus	15:8	00h	New calibration bus signed value.
UseCommonCalibration	16	0b	If set, the PHY's calibration value in bit[6:0] is returned to the PHY ports. If clear, the value after adjustment is returned to the PHY ports.
AddToCommonCalibration	17	1b	If set, the signed NewCalBus is added to the ComCalBus and returned to the PHY ports. Any overflow is clamped to all ones. Any underflow is clamped to all zeros. If clear, the signed NewCalBus replaces the ComCalBus and returns to the PHY ports.
Reserved	23:18	0000h	Read as zero.
CommonPhyCalBus	30:24	7Fh	Read Only. Phy Common Calibration Bus
Reserved	31	0b	
<p>*Note:</p> <p>1. The equation for calibration resistor is as follows:</p> $R_{cal} = 1 / [1/59.4 + CalValue/(1.05*3.8k\ ohm)]$ <p>where the CalValue is the final 7 bits of calibration setting send to PHY.</p> <p>2. The total termination resistance value for HS USB D+/D- should include another 5 ohm resistance from FS driver.</p>			

USB Common PHY Control – RW - 32 bits - [EOR_Reg: EHCI_EOR + A4h]			
Field Name	Bits	Default	Description
CPADJ	3:0	4h	Charge Pump setting for Common Block PLL.
XREFADJ	7:4	1h	External reference bias adjustment for common block.
IREFADJ	11:8	1h	Internal reference bias adjustment for common block.
PVI	15:12	2h	PLL V-I Converter Control for Common Block PLL.
DUTYADJ	19:16	0h	CLK480 Duty cycle control from 40-60% to 60-40%.
Reserved	31:20	000h	Reserved

2.2.5.3 USB2.0 Debug Port Register

This block of registers is memory-mapped. The base offset, Dbase, is directly defined in DBUG_PRT Control register (EHCI_PCI_CFG xE4[28:16], default = 0E0h), regardless of the value in register (MEM_Reg: 00h).

Registers Name	Offset Address
Control / Status	DBase + 00h
USB PIDs	DBase + 04h
Data Buffer	DBase + (08h~0Ch)
Device Address	DBase + 10h

Control / Status – RW - 32 bits - [DBUG_Reg : DBase + 00h]			
Field Name	Bits	Default	Description
Data Length	3:0	0h	For write operations, this field is set by software to indicate to the hardware how many bytes of data in <i>Data Buffer</i> are to be transferred to the console when <i>Write/Read#</i> is set when software sets <i>Go</i> . A value of 0h indicates that a zero-length packet should be sent. A value of 1-8 indicates 1-8 bytes are to be transferred. Values 9-Fh are illegal and how hardware behaves if used is undefined. For read operations, this field is set by hardware to indicate to software how many bytes in <i>Data Buffer</i> are valid in response to software setting <i>Go</i> when <i>Write/Read#</i> is cleared. A value of 0h indicates that a zero length packet was returned. (The state of <i>Data Buffer</i> is not defined.) A value of 1-8 indicates 1-8 bytes were received. Hardware is not allowed to return values 9-Fh. The transferring of data always starts with byte 0 in the data area and moves toward byte 7 until the transfer size is reached.
Write/Read#	4	0b	Software sets this bit to indicate that the current request is a write and clears it to indicate a read.
Go	5	0b	Software sets this bit to cause the hardware to perform a request. Writing this bit to a 1 when the bit is already set may result in undefined behavior. Writing a 0 to this bit has no effect. When set, the hardware clears this bit when the hardware sets the <i>Done</i> bit. (Completion of a request is indicated by the <i>Done</i> bit.)
Error/Good#	6	0b	Read Only Updated by hardware at the same time it sets the <i>Done</i> bit. When set it indicates that an error occurred. Details of the error are provided in the <i>Exception</i> field. When cleared, it indicates that the request terminated successfully.
Exception	9:7	000b	Read Only This field indicates the exception when <i>Error/Good#</i> is set. This field cannot be cleared by software. Reset default = 000b. Value Meaning 000b None 001b Transaction error: indicates the USB2 transaction had an error (CRC, bad PID, timeout, etc.) 010b HW error. Request was attempted (or in progress) when port was suspended or reset. 011b-111b Reserved
In Use	10	0	Set by software to indicate that the port is in use. Cleared by software to indicate that the port is free and may be used by other software. (This bit has no affect on hardware.)
Reserved	15:11		Reserved
Done	16	0	RWC This bit is set by HW to indicate that the request is complete. Writing a 1 to this bit will clear it. Writing a 0 to this bit has no effect.
Reserved	27:17		Reserved

Control / Status – RW - 32 bits - [DEBUG_Reg : DBase + 00h]			
Field Name	Bits	Default	Description
Enabled	28	0	This bit is a one if the debug port is enabled for operation. Software can clear this by writing a zero to it. The controller clears the bit for the same conditions where hardware clears the Port Enable/Disable Change bit (in the PORTSC register). (Note: this bit is not cleared when System Software clears the <i>Port Enabled/Disabled</i> bit (in the PORTSC register). Software can directly set this bit, if the port is already enabled in the associated Port Status and Control register (this is HW enforced).
Reserved	29		Reserved
Owner	30	0	When debug software writes a one to this bit, the ownership of the debug port is forced to the EHCI controller (ie. Immediately taken away from the companion controller). If the port was already owned by the EHCI controller, then setting this bit is has no effect. This bit overrides all of the ownership related bits in the standard EHCI registers. Reset default = 0. Note that the value in this bit may not affect the value reported in the <i>Port Owner</i> bit in the associated PORTSC register.
Reserved	31		Reserved

USB PIDs – RW - 32 bits - [DEBUG_Reg : DBase + 04h]			
Field Name	Bits	Default	Description
Token PID	7:0	00h	The debug port controller sends this PID as the Token PID for each USB transaction. Software will typically set this field to either IN, OUT or SETUP PID values. Reset default = undefined.
Send PID	15:8	00h	The debug port controller sends this PID to begin the data packet when sending data to USB (ie. <i>Write/Read#</i> is asserted). Software will typically set this field to either DATA0 or DATA1 PID values. Reset default = undefined.
Received PID	23:16	00h	Read Only The debug port controller updates this field with the received PID for transactions in either direction. When the controller is sending data (<i>Write/Read#</i> is asserted), this field is updated with the handshake PID that is received from the device. When the host controller is receiving data (<i>Write/Read#</i> is not asserted), this field is updated with the data packet PID (if the device sent data), or the handshake PID (if the device NAKs the request). This field is valid when the controller sets the <i>Done</i> bit. Reset default = undefined.
Reserved	31:24		Reserved

Data Buffer – RW - 64 bits - [DBUG_Reg : DBase + 08h/0Ch]			
Field Name	Bits	Default	Description
Data Buffer	63:0	00000000 – 00000000 h	The least significant byte is accessed at offset 08h and the most significant byte is accessed at offset 0Fh. Each byte in <i>Data Buffer</i> can be individually accessed. <i>Data Buffer</i> must be written with data before software initiates a write request. For a read request, <i>Data Buffer</i> contains valid data when <i>Done</i> is set, <i>Error/Good#</i> is cleared, and <i>Data Length</i> specifies the number of bytes that are valid. Reset default = undefined.

Device Address – RW - 32 bits - [DEBUG_Reg : DBase + 10h]			
Field Name	Bits	Default	Description
USB Endpoint	3:0	1h	4-bit field that identifies the endpoint used by the controller for all Token PID generation.
Reserved	7:4		Reserved
USB Address	14:8	7Fh	7-bit field that identifies the USB device address used by the controller for all Token PID generation.
Reserved	31:15		Reserved

2.3 SMBus Module and ACPI Block (Device 20, Function 0)

This group contains the SMBus, ACPI and Power Management block registers. The SMBus module consists of configuration space, extended configuration, and I/O space mapped registers. SMBus, PM and ACPI registers are NOT cleared by the PCIRST# signal; therefore during a warm boot, the registers will maintain their content.

Some registers in the SMBus/ACPI PCI configuration space (PCI_Reg) contain controls and settings for a number of blocks within the SP5100. *Figure 3* below shows these blocks, with their affected functions and the associated PCI_Reg registers.

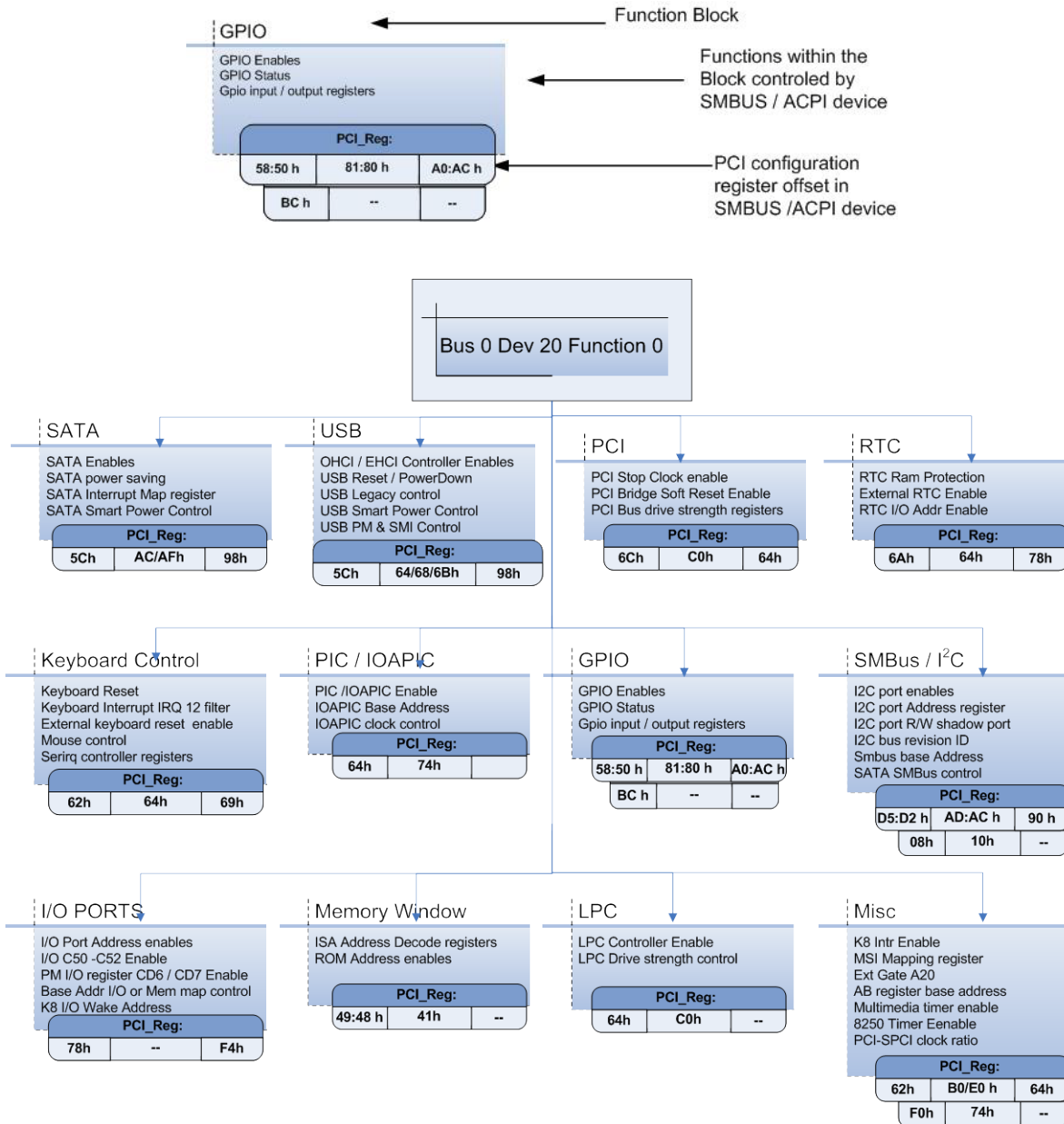

Figure 3 SMBus/ACPI PCI Configuration Space Function Block Association

2.3.1 PCI Configuration Registers and Extended Registers

2.3.1.1 PCI Configuration Registers

Register Name	Configuration Offset
Vendor ID	00h
Device ID	02h
Command	04h
STATUS	06h
Revision ID/Class Code	08h
Cache Line Size	0Ch
Latency Timer	0Dh
Header Type	0Eh
BIST	0Fh
Base Address 0	10h
Base Address 1	14h
Base Address 2	18h
Base Address 3	1Ch
Base Address 4	20h
Base Address 5	24h
Cardbus CIS Pointer	28h
Subsystem Vendor	2Ch
Subsystem ID	2Eh
Expansion ROM Base Address	30h
Capability Pointer	34h
Interrupt Line	3Ch
Interrupt Pin	3Dh
Min_Gnt	3Eh
Max_Lat	3Fh
PCI Control	40h
Misc Function	41h
DMA Limit	42h
DMA Enhance Enable	43h
ISA Address Decode Control Register #1	48h
ISA Address Decode Control Register #2	49h
Scratch Pad	4Ah
GPIO_52_to_49_Cntrl	50h
GPIO_56_to_53_Cntrl	52h
GPIO_60_to_57_Cntrl	54h
GPIO_64_to_61_Cntrl	56h
GPIO_73_to_70_Cntrl	5Ah
Smart Power Control1	5Ch
Misc Enable	62h
Usb3AzIntMap	63h
Features Enable	64h
Serial IRQ Control	69h
RTC Protect	6Ah
USB Reset	6Bh
Test Mode	6Ch
MWAIT Mask	6Eh
IOAPIC_Conf	74h
IO Addr Enable	78h
RTC_Osc_Cntrl	7Ch
GPIO_69_68_66_65_Cntrl	7Eh
GPIO_3_to_0_Cntrl	80h
GPIO_32_31_14_13_Cntrl	82h
Retry Detect	84h
Stuck Detect	88h

Register Name	Configuration Offset
BIOS RAM Base Addr	8Ch
Smbus Base Address	90h
Serial IRQ Status	94h
Smart Power Control2	98h
PM_IO Base Addr	9Ch
IDE_GPIO_Cntrl	A0h
IDE_GPIO_In	A4h
GPIO_48_47_46_37_Cntrl	A6h
GPIO_12_to_4_Cntrl	A8h
SATA_ACT_GPIO_Cntrl	ACH
SATA Enable	ADh
Misc Control	AEnh
SataIntMap	AFh
MSI Mapping Capability	B0h
PCI_INT_GPIO_Cntrl	BCh
UsbIntMap	BEh
IO Drive Strength	C0h
I2CbusConfig	D2h
I2CCommand	D3h
I2CShadow1	D4h
I2Cshadow2	D5h
I2CbusRevision	D6h
MSI Weight	E0h
MiscE1	E1h
AB_REG_BAR	F0h
Wake IO Addr	F4h
MWAIT ID	F6h
MWAIT Status	F7h
Extended Addr Port	F8h
Extended Data Port	FCh

VendorID - R - 16 bits - [PCI_Reg: 00h]			
Field Name	Bits	Default	Description
VendorID	15:0	1002h	Vendor ID
Vendor ID register: Vendor Identification			

DeviceID - R - 16 bits - [PCI_Reg: 02h]			
Field Name	Bits	Default	Description
DeviceID	31:16	4385h	Device ID
Device ID register: Device Identification Number			

Command- RW - 16 bits - [PCI_Reg: 04h]			
Field Name	Bits	Default	Description
I/O Space	0	1b	This bit controls a device's response to IO space accesses. A value of 1 enables it and a value of 0 disables it. Since this module does claim certain legacy IO cycles, this bit is default to 1.
Memory Space	1	1b	This bit controls a device's response to memory space accesses. A value of 1 enables it and a value of 0 disables it. Since this module does claim certain memory cycles if BIOS is strapped to the PCI bus, this bit is default to 1.
Bus Master	2	0b	A value of 0 disables the device from generating PCI accesses. A value of 1 allows it to behave as a bus master. ACPI/SMBus does not have PCI master and so it is always 0. [Read-only]

Command- RW - 16 bits - [PCI_Reg: 04h]			
Field Name	Bits	Default	Description
Special Cycle	3	0b	A value of 0 causes the devices to ignore all special cycle operations. A value of 1 allows the device to monitor Special Cycle operations. This module does not respond to special cycle and so this is hardcoded to 0
Memory Write & Invalidate Enable	4	0b	This bit is an enable bit for using the Memory Write and Invalidate command. This module will not generate this command and so it is always 0. [Read-only]
VGA Palette Snoop	5	0b	This bit controls how VGA compatible and graphics devices handle accesses to VGA palette registers. This does not apply to this module and so it is always 0. [Read-only]
Parity Error Response	6	0b	This bit controls the device's response to parity errors. When the bit is set, the device must take its normal action when a parity error is detected. When the bit is 0, the device must ignore any parity errors that it detects and continue normal operation.
Wait Cycle Control	7	0b	This bit is used to control whether or not a device does address/data stepping. This module does not use address stepping. [Read-only]
SERR# Enable	8	0b	This bit is an enable bit for SERR# driver. A value of 0 disables the SERR# and a value of 1 enables it.
Fast Back-to-Back Enable	9	0b	This bit indicates whether device is fast back-to-back capable. ACPI/SMBus does not support this function and so this bit is always 0. [Read-only]
Reserved	15:10	00h	
PCI Command register			

STATUS- RW - 16 bits - [PCI_Reg: 06h]			
Field Name	Bits	Default	Description
Reserved	3:0	0000b	
MSI Mapping Capability	4	1b	[Read-only] This bit indicates whether the device can support MSI mapping. For K8 system this device is MSI mapping capable so default value is 1
66 MHz Capable	5	1b	This bit indicates whether the device can support 66 MHz. This device is 66 MHz capable. [Read-only]
UDF Supported	6	0b	This bit indicates whether the device supports user definable feature. This module does not support this feature and so it is always 0. [Read-only]
Fast Back-to-Back Capable	7	0b	This bit indicates whether the device is capable of fast back-to-back cycles. This module does not support this feature and so it is always 0. [Read-only]
Data Parity Error Detected	8	0b	Set to 1 if the Parity Error Response bit is set, and the module has detected PERR# asserted while acting as a PCI master (regardless PERR# was driven by this module).
DEVSEL Timing	10:9	01b	These bits encode the timing of DEVSEL#. This module will always respond in medium timing and so these bits are always 11.
Signaled Target Abort	11	0b	This bit is set by a slave device whenever it terminates a cycle with a Target-Abort.
Received Target Abort	12	0b	This bit is set by a master device whenever its transaction is terminated with a Target-Abort.
Received Master Abort	13	0b	This bit is set by a slave device whenever it terminates its transaction with Master-Abort.
Signaled System Error	14	0b	This bit is set by device whenever the device asserts SERR#.
Detected Parity Error	15	0b	This bit is set by device whenever it detects a parity error, even if parity error handling is disabled.
PCI device status register			

Revision ID/Class Code- R - 32 bits - [PCI_Reg: 08h]																		
Field Name	Bits	Default	Description															
Revision ID	7:0	xxh	Revision ID Revision ID field in SMBus can be used to identify the Southbridge revision #. Default revision ID <table border="1"> <tr> <td>Rev</td> <td>ID</td> <td></td> </tr> <tr> <td>A11</td> <td>0x39</td> <td></td> </tr> <tr> <td>A12</td> <td>0x3A</td> <td></td> </tr> <tr> <td>A14</td> <td>0x3C</td> <td></td> </tr> <tr> <td>A15</td> <td>0x3D</td> <td>SP5100 production part revision ID</td> </tr> </table>	Rev	ID		A11	0x39		A12	0x3A		A14	0x3C		A15	0x3D	SP5100 production part revision ID
Rev	ID																	
A11	0x39																	
A12	0x3A																	
A14	0x3C																	
A15	0x3D	SP5100 production part revision ID																
Class Code	31:8	0C0500h	0C0500h denotes a SMBUS controller.															
Revision ID/Class Code register																		

Cache Line Size- R - 8 bits - [PCI_Reg: 0Ch]			
Field Name	Bits	Default	Description
Cache Line Size	7:0	00h	This register specifies the system cacheline size. This module does not use Memory Write and Invalidate command and so this register is not applicable. It is hardcoded to 0.
Cache line size register			

Latency Timer- R - 8 bits - [PCI_Reg: 0Dh]			
Field Name	Bits	Default	Description
Latency Timer	7:0	00h	This register specifies the value of the Latency Timer. This is not used in this module and so it is always 0.
Latency timer register			

Header Type- R - 8 bits - [PCI_Reg: 0Eh]			
Field Name	Bits	Default	Description
Header Type	7:0	80h	This device is a multifunction device.
Header type register			

BIST- R - 8 bits - [PCI_Reg: 0Fh]			
Field Name	Bits	Default	Description
BIST	7:0	00h	The module has no built-in self-test and so this is always 0.
BIST register			

Base Address 0- R - 32 bits - [PCI_Reg: 10h]			
Field Name	Bits	Default	Description
Base Address 0	31:0		Not used. This register is hardcoded to 0.
Base Address 0 register			

Base Address 1- R - 32 bits - [PCI_Reg: 14h]			
Field Name	Bits	Default	Description
Base Address 1	31:0	000h	Not used. This register is hardcoded to 0.
Base Address 1 register			

Base Address 2- R - 32 bits - [PCI_Reg: 18h]			
Field Name	Bits	Default	Description
Base Address 2	31:0	0000_000 0h	Not used. This register is hardcoded to 0.
Base Address 2 register			

Base Address 3- R - 32 bits - [PCI_Reg: 1Ch]			
Field Name	Bits	Default	Description
Base Address 3	31:0	0000_000 0h	Not used. This register is hardcoded to 0.
Base Address 3 register			

Base Address 4- R - 32 bits - [PCI_Reg: 20h]			
Field Name	Bits	Default	Description
Base Address 4	31:0	0000_000 0h	Not used. This register is hardcoded to 0.
Base Address 4 register			

Base Address 5- R - 32 bits - [PCI_Reg: 24h]			
Field Name	Bits	Default	Description
Base Address 5	31:0	0000_000 0h	Not used. This register is hardcoded to 0.
Base Address 5 register			

Cardbus CIS Pointer- R - 32 bits - [PCI_Reg: 28h]			
Field Name	Bits	Default	Description
Cardbus CIS Pointer	31:0	0000_000 0h	Not used. This register is hardcoded to 0.
Cardbus CIS Pointer register			

Subsystem Vendor ID- W - 16 bits - [PCI_Reg: 2Ch]			
Field Name	Bits	Default	Description
Subsystem Vendor ID	15:0	0000h	Write once.
Subsystem Vendor ID register			

Subsystem ID- W - 16 bits - [PCI_Reg: 2Eh]			
Field Name	Bits	Default	Description
Subsystem ID	15:0	0000h	Write once.
Subsystem ID register			

Expansion ROM Base Address - R - 8 bits - [PCI_Reg: 30h]			
Field Name	Bits	Default	Description
Expansion ROM Base Address	7:0	00h	Not used. This register is hardcoded to 0.
Expansion ROM Base Address register			

Capability Pointer - R - 8 bits - [PCI_Reg: 34h]			
Field Name	Bits	Default	Description
Capability Pointer	7:0	B0	Default value is B0h
Capability Pointer register			
Definition of this register applies to Revision A14 and above when the reference clock source is from an external 14 MHz external crystal. The default selection for Revision A14 and above is to use a 14-MHz external crystal, which is initialized by BIOS on POST. Refer to the definition of register PM 0xD4, field AltClk14En, for information on how the reference clock source is selected.			

HPET_CNTRL – R/W - 32 bits - [PCI_Reg: 34h]			
Field Name	Bits	Default	Description
HpetClkPeriod	31:0	00000000	Any change in the register can change the value in hpet clk period register
ImcAccessCntrl register			
Definition of this register applies to Revision A12. For Revision A14 and above, this definition is applicable only in the case where the PCIe® 100-MHz clock, instead of the 14-MHz external crystal, is selected as the reference clock source. The default selection for Revision A14 and above is to use a 14-MHz external crystal, which is initialized by BIOS on POST. Refer to the definition of register PM 0xD4, field AltClk14En, for information on how the reference clock source is selected.			

ImcAccessCntrl – R/W - 32 bits - [PCI_Reg: 38h]			
Field Name	Bits	Default	Description
BlockRtcDone	0	0b	Set to 1 to mask off RTC completion signal to ACPI PCI slave when IMC is accessing ACPI. The bit has to be set to 1 all the time.
ImcHostArbDisEn	1	0b	Set to 1 to disable access the arbiter for IMC and Host. The bit has to be 0 all the time.
MsgImcArbEn	5:2	0000b	Set to 0011b to enable msg when IMC is on. The bits have to be 0011b all the time.
SmbusFilterDis	7	0b	Set to 1 to disable Smbus0 SDA/SCL filtering. The bit has to be 0 all the time.
SlaveBusyDelayDis	9	0b	Set to 1 to disable slave cycle delay. The bit has to be 0 all the time.
MaskHostReqOnPrstDis	10	0b	Set to 1 to not reset slave cycle when PCI reset is asserted. The bit has to be 0 all the time.
DlyusbGoodClk	11	0b	Set to 1 to delay USB GoodClk signal for 6 OSC clocks. The bit has to be 1 all the time.
PmeTimerRst	12	0b	Set to 1 to reset pme wait timer as long as PCI reset is asserted.
ImcAccessCntrl register			

Interrupt Line - R - 8 bits - [PCI_Reg: 3Ch]			
Field Name	Bits	Default	Description
Interrupt Line	7:0	00h	This module does not generate interrupt. This register is hardcoded to 0.
Interrupt Line register			

Interrupt Pin – R - 8 bits - [PCI_Reg: 3Dh]			
Field Name	Bits	Default	Description
Interrupt Pin	7:0	00h	This register specifies which interrupt pin the device issues. This module does not generate interrupt but contains the actual interrupt controller. This register is hardcoded to 0.
Interrupt Pin register			

Min_Gnt - R - 8 bits - [PCI_Reg: 3Eh]			
Field Name	Bits	Default	Description
Min_Gnt	7:0	00h	This register specifies the desired settings for Latency Timer values. Value of 0 indicates that the device has no major requirements for the setting. This value is hardcoded to 0.
Min_Gnt register			

Max_Lat - R - 8 bits - [PCI_Reg: 3Fh]			
Field Name	Bits	Default	Description
Max_Lat	7:0	00h	This register specifies the desired settings for Latency Timer values. Value of 0 indicates that the device has no major requirements for the setting. This value is hardcoded to 0.
Max_Lat register			

PCI Control- RW - 8 bits - [PCI_Reg: 40h]			
Field Name	Bits	Default	Description
id_change_en	0	0b	Setting this bit will allow the software to change the DeviceID and RevisionID
Reserved	1	0b	
kb_pcirst_en	2	0b	When set along with PM_Reg_66[5], assertion on KB_RST# pin will generate a system wide reset
Reserved	3	0	
Reserved	4	0	Obsolete function. This is no longer supported.
Reserved	5	0	
pci_io_en	6	0	PCI to internal ISA IO cycle enable. SW should always program this bit to 1 (smbus controller contains many legacy ISA registers)
Reserved	7	0	
PCI Control register			

Misc Function- RW - 8 bits - [PCI_Reg: 41h]			
Field Name	Bits	Default	Description
Reserved	2:0	001b	
WatchDogDecodeEn	3	0b	Enables watchdog decode
Reserved	4	0b	
MiscfuncEnable	5	0b	When set, this module will decode cycles to IO C50, C51, C52: GPM controls.
Retry21_en	6	0b	This bit is used for internal bus flow control. SW should always set this bit
RetryDma	7	0b	Set to 1 to retry the DMA cycle if the DMA cycle is terminated by AB without data.
Misc Function register			

DMA Limit- RW - 8 bits - [PCI_Reg: 42h]			
Field Name	Bits	Default	Description
DmaBurstLimit	6:0	00h	Enables the amount of burst data the legacy DMA engine can sustain before it should give up the internal bus.
DmaLimitEnable	7	0h	This is an enhancement to the legacy DMA engine. In the original design, certain DMA request (such as Infrared) will cause the legacy DMA engine to dominate the internal bus for a very long time (up to 512 bytes) and thereby causing long latency for other devices. Setting this bit will cause the legacy DMA engine to limit its transfer per burst based on bits [6:0]
DMA Limit register			

DMA Prefetch Enable - RW - 8 bits - [PCI_Reg: 43h]			
Field Name	Bits	Default	Description
DmaPrefetchEnable	0	0b	Legacy read DMA prefetch function enable. 1: Enable 0: Disable When set, the DMA engine will keep the data inside the FIFO, even though the requesting device has deasserted the DMA request. When the device requests data again, the DMA engine will have data available instead of having to fetch data from the memory again. Note this enhancement only applies to channel 0, 1, 2, and 3. It has no effect on channel 5, 6, or 7
Reserved	2:1	00b	
HPETBarHid	3	1b	1: Make registers from 10h to 3Fh invisible 0: Make registers from 10h to 3Fh read/write
HPETDecodeEn	4	0b	1: Enable decoding of access to HPET MMIO 0: Disable decoding of access to HPET MMIO
HPET_MSI_En0	5	0b	Enables Timer0 MSI
HPET_MSI_En1	6	0b	Enables Timer1 MSI
HPET_MSI_En2	7	0b	Enables Timer2 MSI

Reserved A- RW - 8 bits - [PCI_Reg: 48:49h]			
Field Name	Bits	Default	Description
Reserved	15:0	FF0Fh	SW should not change this register

Shadow- RW - 8 bits - [PCI_Reg: 4Ah]			
Field Name	Bits	Default	Description
Reserved	3:0	0000b	
HPETSpecialClkEn	4	0b	Set to enable the logic that regulates the reading of HPET counter (async logic to transfer reading from 14MHz domain to 66MHz)
Reserved	5	0b	
Reserved	6	0b	Obsolete function; no longer used
ReadShadow	7	0b	Shadow PIC register enable. When set, shadow IO ports (x21, xA1) are enabled.
Shadow register			

BootFailTimer- RW - 32 bits - [PCI_Reg: 4Ch]			
Field Name	Bits	Default	Description
BootTimerCount	24:0	-	This returns the current value of the Boot timer count. The timer is hard coded to trigger at 25'h100_0000 (equivalent to ~1 second)
Reserved	29:25	00h	
ResetByBootTimer	30	0b	This bit is 1 if the previous reset is caused by the boot timer. Software can write 0 to clear this bit.
BootTimerDisable	31	0b	This bit has no meaning if debug strap is not enabled. If enabled, this bit is used (write 1) to disable the boot failure timer. If the boot failure timer is enabled, it will start to count as soon as system comes out from reset. BIOS needs to disable this timer (through this bit) before the timer expires at ~1 second after reset.

BootFailTimer- RW - 32 bits - [PCI_Reg: 4Ch]			
Field Name	Bits	Default	Description
BootFailTimer register			
<p>The contents of this register will not have any effect if the BootFailTimer strap is disabled. The purpose of the BootFailTimer is to support the Sure Boot feature which allows the system to be reset if any power on / boot cycle is not successfully completed. The BootFailTimer, if enabled by the Hardware Strap and the BIOS does not disable it within one second, will expire and cause the following hardware signals to be asserted or de-asserted.</p> <p><i>NB_PWRGD</i> – will be de-asserted in addition to System Reset</p> <p>System Reset definition { <i>PCIRST#</i> will be asserted <i>ARST#</i> will be asserted <i>ROM_RST#</i> will be asserted <i>LDT_RST#</i> will be asserted <i>LDT_PG</i> will be de-asserted (if <i>PMIO_42h[3]</i> = 1 && <i>PMIO_42h[1]</i> = 0) }</p> <p>This event will cause a warm reset condition and initiate the system boot process again. For unsuccessful system boot up caused by intermittent failures, the next boot cycle should (hopefully) be successful boot and avoid system hard lock conditions.</p>			

GPIO_52_to_49_Cntrl - RW – 16 bits - [PCI_Reg: 50h]			
Field Name	Bits	Default	Description
GPIO_Out	3:0	0h	Write 1 to set and 0 to clear each of the GPIO port; providing the corresponding enable bits (7:4) are set to 0 Bit [0] for GPIO49/FANOUT2 Bit [1] for GPIO50/FANIN0 Bit [2] for GPIO51/FANIN1 Bit [3] for GPIO52/FANIN2
GPIO_Out_En#	7:4	Fh	GPIO output port enable for each of the GPIO port 0: Output = GPIO_Out 1: Output = tristate
GPIO_Status	11:8	-	GPIO input status for each of the GPIO port
Reserved	15:12	0h	
GPIO_52_to_49_Cntrl register			

GPIO_56_to_53_Cntrl - RW – 16 bits - [PCI_Reg: 52h]			
Field Name	Bits	Default	Description
GPIO_Out	3:0	0h	Write 1 to set and 0 to clear each of the GPIO port; providing the corresponding enable bits (7:4) are set to 0 Bit [0] for GPIO53/VIN0 Bit [1] for GPIO54/VIN1 Bit [2] for GPIO55/VIN2 Bit [3] for GPIO56/VIN3
GPIO_Out_En#	7:4	Fh	GPIO output port enable for each of the GPIO port 0: Output = GPIO_Out 1: Output = tristate
GPIO_Status	11:8	-	GPIO input status for each of the GPIO port
Reserved	15:12	0h	
GPIO_56_to_53_Cntrl register			

GPIO_60_to_57_Cntrl - RW – 16 bits - [PCI_Reg: 54h]			
Field Name	Bits	Default	Description
GPIO_Out	3:0	0h	Write 1 to set and 0 to clear each of the GPIO port providing the corresponding enable bits (7:4) are set to 0 Bit [0] for GPIO57/VIN4 Bit [1] for GPIO58/VIN5 Bit [2] for GPIO59/VIN6 Bit [3] for GPIO60/VIN7
GPIO_Out_En#	7:4	Fh	GPIO output port enable for each of the GPIO port 0: Output = GPIO_Out 1: Output = tristate
GPIO_Status	11:8	-	GPIO input status for each of the GPIO port
Reserved	15:12	0h	
GPIO_60_to_57_Cntrl register			

GPIO_64_to_61_Cntrl - RW – 16 bits - [PCI_Reg: 56h]			
Field Name	Bits	Default	Description
GPIO_Out	3:0	0h	Write 1 to set and 0 to clear each of the GPIO port providing the corresponding enable bits (7:4) are set to 0 Bit [0] for GPIO61/TEMPIN0 Bit [1] for GPIO62/TEMPIN1 Bit [2] for GPIO63/TEMPIN2 Bit [3] for GPIO64/TEMPIN3
GPIO_Out_En#	7:4	Fh	GPIO output port enable for each of the GPIO port 0: Output = GPIO_Out 1: Output = tristate
GPIO_Status	11:8	-	GPIO input status for each of the GPIO port
Reserved	15:12	0h	
GPIO_64_to_61_Cntrl register			

ASFSMbusIoBase- RW - 16 bits - [PCI_Reg: 58h]			
Field Name	Bits	Default	Description
ASFSMBusEnable	0	0b	0: Disable ASF controller 1: Enable ASF controller
Reserved	4:1		
ASFSMBase	15:5	FFFh	ASF SM bus controller IO base address [15:5]

GPIO_73_to_70_Cntrl - RW – 16 bits - [PCI_Reg: 5Ah]			
Field Name	Bits	Default	Description
GPIO_Out	3:0	0h	Write 1 to set and 0 to clear each of the GPIO port ; providing the corresponding GPIO_OUT_En# and GPIO_Enable are set appropriately Bit [0] for GPIO70/REQ3# Bit [1] for GPIO71/REQ4# Bit [2] for GPIO72/GNT3# Bit [3] for GPIO73/GNT4#
GPIO_Out_En#	7:4	Fh	GPIO output port enable for each of the GPIO port 0: Output = GPIO_Out 1: Output = tristate
GPIO_Status	11:8	-	GPIO input status for each of the GPIO port
GPIO_Enable	15:12	0h	GPIO function enable for each of the GPIO port When set, the pin becomes GPIO 0: GPIO disabled 1: GPIO enabled
GPIO_73_to_70_Cntrl register			

Smart Power Control1 - RW – 24 bits - [PCI_Reg: 5Ch]			
Field Name	Bits	Default	Description
CheckLpc	0	0b	If SmartVoltEnable is set and this bit is also set, the SmartPower function will only assert SmartVolt if LPC is idle
CheckAz	1	0b	If SmartVoltEnable is set and this bit is also set, the SmartPower function will only assert SmartVolt if azalia (HD audio) is idle
Reserved	2	0b	
CheckPciBridge	3	0b	If SmartVoltEnable is set and this bit is also set, the SmartPower function will only assert SmartVolt if azalia PCIBridge is idle
reserved	4	0b	
CheckSata	5	0b	If SmartVoltEnable is set and this bit is also set, the SmartPower function will only assert SmartVolt if SATA is idle
CheckIde	6	0b	If SmartVoltEnable is set and this bit is also set, the SmartPower function will only assert SmartVolt if IDE is idle
CheckC3	7	0b	If SmartVoltEnable is set and this bit is also set, the SmartPower function will only assert SmartVolt if CPU is in C3 state
CheckVIN0	8	0b	If SmartVoltEnable is set and this bit is also set, the SmartPower function will only assert SmartVolt if VIN0 has reached or passed the threshold
CheckVIN1	9	0b	If SmartVoltEnable is set and this bit is also set, the SmartPower function will only assert SmartVolt if VIN1 has reached or passed the threshold
CheckVIN2	10	0b	If SmartVoltEnable is set and this bit is also set, the SmartPower function will only assert SmartVolt if VIN2 has reached or passed the threshold
CheckVIN3	11	0b	If SmartVoltEnable is set and this bit is also set, the SmartPower function will only assert SmartVolt if VIN3 has reached or passed the threshold
CheckVIN4	12	0b	If SmartVoltEnable is set and this bit is also set, the SmartPower function will only assert SmartVolt if VIN4 has reached or passed the threshold
CheckVIN5	13	0b	If SmartVoltEnable is set and this bit is also set, the SmartPower function will only assert SmartVolt if VIN5 has reached or passed the threshold
CheckVIN6	14	0b	If SmartVoltEnable is set and this bit is also set, the SmartPower function will only assert SmartVolt if VIN6 has reached or passed the threshold
CheckVIN7	15	0b	If SmartVoltEnable is set and this bit is also set, the SmartPower function will only assert SmartVolt if VIN7 has reached or passed the threshold
SmartVoltIdleTime	22:16	0h	Amount of "idle" time (in 2us increment) the SmartPower function should wait before it should assert SmartVolt
SmartVoltEnable	23	0b	Enable bit for the SmartPower function. When set, the logic will monitor the logic (defined by 5Ch). If all of the the corresponding modules are idle,
<p>Smart Power Control1 register</p> <p>SmartVolt function is meant to provide a mechanism to control the external power supply in order to reduce additional system power consumption. For example, software can set Smart Power Control1 bit [6] and [7]. Whenever CPU enters C3 state and IDE (PATA) controller is not active, this function will assert SMARTVOLT/GPIO4. System design can use this signal to control the power supply to reduce the ATA power by 5~10%. Another example is to connect an ambient light sensor to one of the VIN inputs. When the circuit has detected the ambient light is below certain threshold, this function can automatically dim the LCD back light</p>			

Reserved B- RW - 16 bits - [PCI_Reg: 60h]			
Field Name	Bits	Default	Description
Reserved	15:0	0000h	SW must not write to this register; adverse effect may happen if written

Misc Enable- RW - 8 bits - [PCI_Reg: 62h]			
Field Name	Bits	Default	Description
IRQ1_Filter	0	0b	Keyboard interrupt filter enable (IRQ1) Filtering is done so that the first rising edge of IRQ1 would cause the IRQ1 going to the PIC (8259 programmable interrupt controller) to go asserted, but subsequent changes to IRQ1 would not have any effect on the IRQ1 going to the PIC until a access to the keyboard was done (I/O read of port 60. The Main effect is that software could mask IRQ1, do several accesses / commands to the keyboard controller that subsequently cause numerous IRQ1's, do one final I/O read access of port 60 and know that when IRQ1 was unmasked that no pending keyboard interrupt would be generated.
IRQ12_Filter	1	0b	Mouse Interrupt Filter Enable (IRQ12) 0: Disable IRQ12 filtering 1: Enable IRQ12 filtering
K8_INTR	2	0b	K8 INTR Enable (BIOS should set this bit after PIC initialization) 0: Disable K8 INTR message 1: Enable K8 INTR message
MT3_Set	3	0b	If this bit is set, K8 INTR NMI Message Type field (bit [3]) is forced to be 1; otherwise K8 INTR NMI Message Type is controlled by MT3_Auto. Recommended method is to use MT3_Auto bit. In AMD K8 system, all interrupts are sent to CPU via messages. In MP base (such as Linux), the message may need to be in certain format.
MT3_Auto	4	0b	If this bit is set, K8 INTR NMI Message Type field (bit [3]) is 1 if APIC is also active; otherwise K8 INTR NMI Message Type is 0.
USBLegacyOrderingDis	5	0	Controls ordering of the I/O 64/60 completion with respect to SMI generation. 0: Enable 1: Disable Set to '1' as per RPR's section "Disabling Legacy USB Fast SMI#". Function has side effect if enabled. It is redundant as it is covered by USB legacy logic; therefore it can be safely disabled.
SMAFMatchControl	6	0b	0 – All STPCLK/STPGNT SMAF values must match 1 – No matching is required
IDE_GPIO_Enable	7	0b	If this bit is set, the IDE bus is configured as GPIO
Misc Enable register			

Usb3AzIntMap- RW - 8 bits - [PCI_Reg: 63h]			
Field Name	Bits	Default	Description
AzIntMap	2:0	110b	Interrupt routing table for HD Audio. Setting this register routes the HD audio's interrupt to the specific PCI interrupt before it is routed to the interrupt controller. In general software should not need to reroute HDaudio interrupt. SW only needs to do so for debugging purpose or special circumstance
ImcIRQ12En	3		Set to 1 to enable the IRQ12 coming from IMC
Usb3IntMap	6:4	010b	Interrupt routing table for USB3 (stand alone OHCI controller)

Usb3AzIntMap- RW - 8 bits - [PCI_Reg: 63h]			
Field Name	Bits	Default	Description
ImcIRQ1En	7		Set to 1 to make IRQ1 comes from IMC
AzIntMap register Encoding: 000: INTA# 001: INTB# 010: INTC# 011: INTD# 100: INTE# 101: INTF# 110: INTG# 111: INTH#			

Features Enable- RW - 32 bits - [PCI_Reg: 64h]			
Field Name	Bits	Default	Description
PIC_Enable	0	1b	PIC (8259) Programmable Interrupt Controller enable 0: I/O cycles to master PIC:20,21, slave PIC:a0, a1, ELCR registers 4D0, 4D1h, and the PCI interrupt Mapping Registers (C00, C01), and Numeric Coprocessor Error Register (IRQ13) (0F0h) are not accepted. 1: (Default). I/O cycles to APIC are not decoded but I/O cycles to these above addresses will be positive decoded on PCI and run to the internal 8259 PIC
Timer_Enable	1	1b	0: I/O cycles to timers/counter (040-043h) will not be claimed on ISA 1: I/O cycles to timers/counter will be claimed on ISA and run to the internal 8254 Timer/Counter
PMIO_Register Enable	2	1b	Power management enable register 0: I/O cycles to Power management registers (CD6 and CD7h) will not be claimed 1: I/O cycles to Power management registers will be claimed and run to the internal Power Management logic (BIOS should always set it to 1)
Ioapic_enable	3	0b	When set, this block will decode ioapic address
CheckOwnReq	4	0b	If set, the SP5100 will check its own REQ# as the PCI_ACTIVE signal in addition to BMREQ#. This is used in conjunction with C3 stutter mode. In other words, if the SP5100 has DMA traffic going upstream, the SP5100 will examine its own traffic and toggle LDTSTP# accordingly during C3 state.
BmReqEnable	5	0b	Enable BMREQ# pin to the C state logic
Reserved	6	0b	
XIOAPIC_ENA	7	1b	XIOAPIC enable. This bit is only valid if bit [3] is set.
GEVENT5_ENA	8	0b	The BIOS should always set this bit to 1 to enable GEVENT5.
Ext_KBRST_EnB	9	0b	Enable external KB_RST# input. When set to 0, GEVENT[1] is used as KBRST# input
HPETIrqEn	10	0b	High Precision Event Timer (also called Multimedia Timer) interrupt enable
Ext_A20En	11	0b	Enable external Ga20In input (generated from the external SIO). When set to 1, GEVENT[0] is used as Ga20In input
Smi_Gevent_En	12	0b	Enable all the events with the capability of doing both SMI and SCI to SMI# assertion. If enabled, an assertion at any of the event inputs will cause SMI# to be asserted if SCI EN is not set. 0: Disable 1: Enable

Features Enable- RW - 32 bits - [PCI_Reg: 64h]			
Field Name	Bits	Default	Description
Intr_block_En	13	0b	Applicable in the PIC system. When enabled, it will block any pending interrupt for approximately 500ns after IntrAck cycle from the host. 0: Disable 1: Enable
ApicPort02Swap	14	0b	When set, port 0 of APIC is connected to output of the PIC and port 2 is connected to IRQ0 (timer0) When clear, port 0 of APIC is connected to IRQ0 (timer0) and port 2 is connected to the output of the PIC. Software should set this bit to conform with MP spec.
UsbSmiEn	15	0b	USB SMI# enable: 1: Enable 0: Disable
Serr2Smi_En	16	0b	Enable SERR# to SMI# assertion 0: Disable 1: Enable
Gevent1_en0	17	0b	GEVENT group 0 enable (GPM[7] to SMI/SCI enable) to ACPI function
Gevent1_en1	18	0b	GEVENT group 1 enable (GPM[6] to SMI/SCI enable) to ACPI function
Gevent1_en2	19	0b	GEVENT group 2 enable (GPM[5:4] to SMI/SCI enable) to ACPI function
LpcEnable	20	1b	1: Enable lpc controller 0: Disable lpc controller This is for debugging purpose only. SW should not set this bit to 0
RtcSelect	21	0b	Writing this bit with 1 will toggle the selection between internal RTC and external RTC which is set via a strap bit. Reading this bit returns the internal/external mode: 1: External RTC 0: Internal RTC
Gevent1_en3	22	0b	GEVENT group 3 enable (ExtEvent[1:0], PCIePme) to ACPI function
Gevent1_en4	23	0b	GEVENT group 4 enable (GPM[3:0]) to ACPI function
Reserved	24	1b	
DmaVerifyEn	25	0b	With LPC replacing the ISA bus, software needs to set this bit in order to for DMA verify mode to work properly
IRQ1MergeEn	26	0b	This is the old method to merge the normal IRQ1 with the USB legacy IRQ1 function. Since this is no longer needed, software should always set this bit to 0
IRQ12MergeEn	27	0b	This is the old method to merge the normal IRQ12 with the USB legacy IRQ12 function. Since this is no longer needed, software should always set this bit to 0
Reserved	29:28	00b	
UsbA20En	30	0b	Enables the USB A20 function to be merged with PS2 A20gate
UsbLegacyIrqEn	31	0b	Enable for IRQ1/12 from USB
Features Enable register			

USB Enable - RW - 8 bits - [PCI_Reg: 68h]			
Field Name	Bits	Default	Description
USB1 OHCI0 enable	0	1b	Set to 1 to enable OHCI0 in USB1 controller (device-18)
USB1 OHCI1 enable	1	1b	Set to 1 to enable OHCI1 in USB1 controller (device-18)
USB1 EHCI enable	2	1b	Set to 1 to enable EHCI in USB1 controller (device-18)
Reserved	3		
USB2 OHCI0 enable	4	1b	Set to 1 to enable OHCI0 in USB2 controller (device-19)
USB2 OHCI1 enable	5	1b	Set to 1 to enable OHCI1 in USB2 controller (device-19)
USB2 EHCI enable	6	1b	Set to 1 to enable EHCI in USB2 controller (device-19)

USB Enable - RW - 8 bits - [PCI_Reg: 68h]			
Field Name	Bits	Default	Description
USB3 OHCI enable	7	1b	Set to 1 to enable OHCI in USB3 controller (device-20, fun-5)
USB Enable register			

Serial IRQ Control- RW - 8 bits - [PCI_Reg: 69h]			
Field Name	Bits	Default	Description
NumStartBits	1:0	00b	This field defines the number of clocks in the start frame. Start Frame Width = 4 + 2 * NumStartBits
NumSerIrqBits	5:2	0h	Total number of serial IRQ's = 17 + NumSerIrqbits 0: 17 serial IRQ's (15 IRQ, SMI#, + IOCHK#) 1: 18 serial IRQ's (15 IRQ, SMI#, IOCHK#, INTA#) ... 15 - 32 serial IRQ's The SP5100 serial IRQ can support 15 IRQ#, SMI#, IOCHK#, INTA#, INTB#, INTC#, and INTD#. When serial SMI# is used, BIOS will need to check SIO (or device that generates serial SMI#) for status.
SerIrqMode	6	0b	0: Continuous mode 1: Active (quiet) mode
SerialIrqEnable	7	0b	Setting this bit to 1 enable the serial IRQ function
Serial IRQ Control register			

RTC Protect- RW - 8 bits - [PCI_Reg: 6Ah]			
Field Name	Bits	Default	Description
RTCProtect38_3F	0	0b	When set, RTC RAM index 38:3Fh will be locked from read/write. This bit can only be written once.
RTCProtectF0_FF	1	0b	When set, RTC RAM index F0:FFh will be locked from read/write. This bit can only be written once.
RTCProtectE0_EF	2	0b	When set, RTC RAM index E0:EFh will be locked from read/write. This bit can only be written once.
RTCProtectD0_DF	3	0b	When set, RTC RAM index D0:DFh will be locked from read/write. This bit can only be written once.
RTCProtectC0_CF	4	0b	When set, RTC RAM index C0:CFh will be locked from read/write. This bit can only be written once.
IDE_IRQ_filter_en	5	0b	Debounce IDE IRQ pulse for 30ns; mainly used for suppressing noise
Reserved	6	0b	
Reserved	7	0b	
RTC Protect register			

USB Reset RW - 8 bits - [PCI_Reg: 6Bh]			
Field Name	Bits	Default	Description
ForceReset2USB	4:0	00h	These are software control bits that can be used to force reset the USB host controllers. Each bit corresponds to one USB controller
ForceUSBPHYpwrDown	5	0b	Forces USB PHY into power down mode.
ForcePHYPLLpwrDown	6	0b	Forces USB PHY PLL into power down mode.
ForceUSBPortPHYReset	7	0b	Forces USB PHY reset.
USB Reset register			

Test Mode- RW - 16 bits - [PCI_Reg: 6C]			
Field Name	Bits	Default	Description
DMA_Timing	0	0b	To be used by the BIOS only. This is to adjust the timing of the legacy DMA inside the internal bus. Software should always set this bit.

Test Mode- RW - 16 bits - [PCI_Reg: 6C]			
Field Name	Bits	Default	Description
TestMode	4:1	0h	These bits are for testing only. Software should not write to these bits.
PCIB_SReset_En Mask	5	0b	When set, PCIBridge reset control bit PCIB_SReset_En (x3e bit 22 of PCI Bridge) will be writable.
TestMode	15:6	000h	These bits are for testing only. Software should not write to these bits.
Test Mode register			

Reserved C- RW - 16 bits - [PCI_Reg: 6E]			
Field Name	Bits	Default	Description
Reserved	15:0	0000h	
Reserved C register (usage TBD)			

Run Time Test- R - 32 bits - [PCI_Reg: 70h]			
Field Name	Bits	Default	Description
RunTimeTest	31:0	0000_000 0h	These bits are for testing only. Software should not write to these bits.
Run Time Test register			

IOAPIC_Conf- RW - 32 bits - [PCI_Reg: 74h]			
Field Name	Bits	Default	Description
Reserved	2:0	000b	
Mem_IO_Map	3	1b	Base address mapping 1: Memory map 0: IO map
Reserved	4	0b	
IOAPIC_Addr	31:5	1111_ 1110_ 1100_ 0000_ 0000_ 0000_ 000b	Base address for IOAPIC (default to FEC000xx)
IOAPIC_Conf register			

IO Addr Enable - RW - 32 bits - [PCI_Reg: 78h]			
Field Name	Bits	Default	Description
DmaAddr_En	0	1b	Enable to decode 0x000:0x01F, 0x080:0x08F, 0x0C0:0xCF, 0x0D0:0xDF, 0x40B, 0x4D6,
PitAddr_En	1	1b	Enable to decode 0x40, 0x41, 0x42, 0x43
NmiAddr_En	2	1b	Enable to decode 0x70
RtcAddr_En	3	1b	Enable to decode 0x71
Misc_Enable1	4	1b	Enable to decode 0xC14
Misc_Enable2	5	1b	Enable to decode 0xC49, 0xC4A
Misc_Enable3	6	1b	Enable to decode 0xC52
Misc_Enable4	7	1b	Not used
Misc_Enable5	8	1b	Not used
PM_Addr_Enable	9	1b	Enable to 0xCD6,0 xCD7
Reserved	10	0b	Can be used as scratch bit
Cms_Enable	11	1b	Enable to decode 0xC50, 0xC51
Reserved	13:12	00b	Can be used as scratch bit
Port92Enable	14	1b	Enable to decode 92
Reserved	31:15	00000h	

IO Addr Enable - RW - 32 bits - [PCI_Reg: 78h]			
Field Name	Bits	Default	Description
IO Addr Enable Register: When a bit is set, this block will decode the corresponding address. If the bit is cleared, this block will not claim the corresponding address. This is to allow the legacy port to be behind the PCI bridge.			

RTC_Osc_Cntrl - RW – 8 bits - [PCI_Reg: 7Ch]			
Field Name	Bits	Default	Description
Rtc_test_en	0	0b	This is the test enable for the rtc 32Khz oscillator control bits
Rtc_osc_set_en	1	0b	This is the latch enable for the rtc 32Khz oscillator control bits (rtc_osc_set0, rtc_osc_set1)
Rtc_osc_set0	2	0b	Rtc oscillator control bit; test purpose only
Rtc_osc_set1	3	0b	Rtc oscillator control bit; test purpose only
Reserved	7:4	0h	
RTC_Osc_Cntrl register			

Reserved - RW – 8 bits - [PCI_Reg: 7Dh]			
Field Name	Bits	Default	Description
Reserved	7:0	00h	

GPIO_69_68_66_65_Cntrl - RW – 16 bits - [PCI_Reg: 7Eh]			
Field Name	Bits	Default	Description
GPIO_Out	3:0	0h	Write 1 to set and 0 to clear each of the GPIO port providing the corresponding bits [7:4] are enabled Bit [0] for GPIO65/BMREQ# Bit [1] for GPIO66/LLB# Bit [2] for GPIO68/LDRQ1# Bit [3] for GPIO69/RTC_IRQ#
GPIO_Out_En#	7:4	Fh	GPIO output port enable for each of the GPIO port 0: Output = GPIO_Out 1: Output = tristate
GPIO_Status	11:8	-	GPIO input status for each of the GPIO port
Reserved	15:12	0h	
GPIO_69_68_66_65_Cntrl register			

GPIO_3_to_0_Cntrl - RW – 16 bits - [PCI_Reg: 80h]			
Field Name	Bits	Default	Description
GPIO_Out	3:0	0h	Write 1 to set and 0 to clear each of the GPIO port providing the corresponding bits [7:4] are enabled Bit [0] for GPIO0/SSMUXSEL Bit [1] for GPIO1/ROM_CS# Bit [2] for GPIO2/SPKR Bit [3] for GPIO3/FANOUT0
GPIO_Out_En#	7:4	Fh	GPIO output port enable for each of the GPIO port 0: Output = GPIO_Out 1: Output = tristate For GPIO1, this is applicable only if we are not using the external PCI bus as the ROM interface.
GPIO_Status	11:8	-	GPIO input status for each of the GPIO port
Reserved	15:12	0h	
GPIO_3_to_0_Cntrl register			

GPIO_32_31_14_13_Cntrl - RW – 16 bits - [PCI_Reg: 82h]			
Field Name	Bits	Default	Description
GPIO_Out	3:0	0h	Write 1 to set and 0 to clear each of the GPIO port providing the corresponding bits [7:4] and [15:12] are enabled Bit [0] for GPIO13/LAN_RST# Bit [1] for GPIO14/ROM_RST# Bit [2] for GPIO31/SPI_HOLD# Bit [3] for GPIO32/SPI_CS#
GPIO_Out_En#	7:4	Fh	GPIO output port enable for each of the GPIO port 0: Output = GPIO_Out 1: Output = tristate
GPIO_Status	11:8	-	GPIO input status for each of the GPIO port
GPIO_Enable	15:12	0h	GPIO function enable for each of the GPIO port 0: GPIO disabled 1: GPIO enabled
GPIO_32_31_14_13_Cntrl register			

BIOS RAM Base Addr- RW – 32 bits - [PCI_Reg: 8Ch]			
Field Name	Bits	Default	Description
bios_ram_mem_enable	0	0b	Set to 1 to enable memory mapping of the 256 byte BIOS RAM
Reserved	7:1	0000_000 b	
bios_ram_mem_baddr	31:8	000000h	Base address of the memory mapped 256 byte BIOS RAM
BIOS RAM Base Addr register			

Smbus Base Address - R – 32 bits - [PCI_Reg: 90h]			
Field Name	Bits	Default	Description
IO/Memory	0	1b	1: IO 0: Memory
Reserved	3:1		
SmBusBaseAddr	31:4	0000000h	SMBus Base Address [31:4]
Smbus Base Address register (also accessible through 10h)			

Serial IRQ Status- R – 24 bits - [PCI_Reg: 94h]			
Field Name	Bits	Default	Description
Internal_irq_sts	23:0		This is for debugging purpose only. This register shows each of the 24 interrupt status going into the IOAPIC. Note that the polarity of certain bits are reversed.
Serial IRQ Status register			

Smart Power Control2 - RW – 24 bits - [PCI_Reg: 98h]			
Field Name	Bits	Default	Description
CheckLpc	0	0b	If SmartVoltEnable2 is set and this bit is also set, the SmartPower2 function will only assert SmartVolt2 if LPC is idle
CheckAz	1	0b	If SmartVoltEnable2 is set and this bit is also set, the SmartPower2 function will only assert SmartVolt2 if azalia (HD audio) is idle
Reserved	2	0b	
CheckPciBridge	3	0b	If SmartVoltEnable2 is set and this bit is also set, the SmartPower2 function will only assert SmartVolt2 if azalia PCIBridge is idle
Reserved	4	0b	
CheckSata	5	0b	If SmartVoltEnable2 is set and this bit is also set, the SmartPower2 function will only assert SmartVolt2 if SATA is idle

Smart Power Control2 - RW – 24 bits - [PCI_Reg: 98h]			
Field Name	Bits	Default	Description
CheckIde	6	0b	If SmartVoltEnable2 is set and this bit is also set, the SmartPower2 function will only assert SmartVolt2 if IDE is idle
CheckC3	7	0b	If SmartVoltEnable2 is set and this bit is also set, the SmartPower2 function will only assert SmartVolt2 if CPU is in C3 state
CheckVIN0	8	0b	If SmartVoltEnable is set and this bit is also set, the SmartPower function will only assert SmartVolt2 if VIN0 has reached or passed the threshold
CheckVIN1	9	0b	If SmartVoltEnable is set and this bit is also set, the SmartPower function will only assert SmartVolt2 if VIN1 has reached or passed the threshold
CheckVIN2	10	0b	If SmartVoltEnable is set and this bit is also set, the SmartPower function will only assert SmartVolt2 if VIN2 has reached or passed the threshold
CheckVIN3	11	0b	If SmartVoltEnable is set and this bit is also set, the SmartPower function will only assert SmartVolt2 if VIN3 has reached or passed the threshold
CheckVIN4	12	0b	If SmartVoltEnable is set and this bit is also set, the SmartPower function will only assert SmartVolt2 if VIN4 has reached or passed the threshold
CheckVIN5	13	0b	If SmartVoltEnable is set and this bit is also set, the SmartPower function will only assert SmartVolt2 if VIN5 has reached or passed the threshold
CheckVIN6	14	0b	If SmartVoltEnable is set and this bit is also set, the SmartPower function will only assert SmartVolt2 if VIN6 has reached or passed the threshold
CheckVIN7	15	0b	If SmartVoltEnable is set and this bit is also set, the SmartPower function will only assert SmartVolt2 if VIN7 has reached or passed the threshold
SmartVoltIdleTime2	22:16	0h	Amount of "idle" time (in 2us increment) the SmartPower2 function should wait before it should assert SmartVolt 2
SmartVoltEnable2	23	0b	Enable bit for the SmartPower2 function. When set, the logic will monitor the logic (defined by 98h). If all of the the corresponding modules are idle,
<p>Smart Power Control2 register</p> <p>SmartVolt function is meant to provide a mechanism to control the external power supply in order to reduce additional system power consumption. For example, software can set Smart Power Control2 bit [6] and [7]. Whenever CPU enters C3 state and IDE (PATA) controller is not active, this function will assert GPIO5/SHUTDOWN/SMARTVOLT2 pin. System design can use this signal to control the power supply to reduce the ATA power by 5~10%. Another example is to connect an ambient light sensor to one of the VIN inputs. When the circuit has detected the ambient light is below certain threshold, this function can automatically dim the LCD back light.</p>			

SBResourceMMIO Base – RW - 32 bits - [PCI_Reg:9C]			
Field Name	Bits	Default	Description
Mmio_io_enable	0	0b	Set to 1 to enable the Io space to map in all the acpi register block. In previous SB, there are various legacy IO ports and they are scattered among IO address. In SP5100, all these legacy IO address are remapped onto one unified memory mapped address. The mapping of these registers are shown in figure below
Mmio_mem_enabl	1	0b	Set to 0 to enable the Memory space to map in all the acpi register block
Reserved	11:2	0h	
Mmio_baddr	31:8	0h	Base address of the Io space or Memory space

SBResourceMMIO_Base – RW - 32 bits - [PCI_Reg:9C]			
Field Name	Bits	Default	Description
SBResourceMMIO_Base register			
Offset	000: 0FF		SMBUS PCI configuration registers
	100: 1FF		SMBUS extended registers
	200: 2FF		CM (client management registers)
	300: 3FF		PMIO
	400: 4FF		PMIO2
	500: 5FF		BIOS_RAM
	600: 6FF		CMOS_RAM
	700: 7FF		CMOS
	800: 8FF		Not used
	900: 9FF		ASF registers
	A00: AFF		Smbus registers
	B00: BFF		WatchDogTimer registers

IDE_GPIO_Cntrl – RW - 32 bits - [PCI_Reg:A0]			
Field Name	Bits	Default	Description
GPIO_Out	15:0	0000h	When the IDE bus is used as GPIO, these bits control the output of each IDE data bit; providing the corresponding bits [31:16] are enabled
GPIO_Out_En#	31:16	FFFFh	When the IDE bus is used as GPIO, these bits control the output enable of each IDE data bit. 0: Enable 1: Tristate
IDE_GPIO_Cntrl register			

IDE_GPIO_In – R - 16 bits - [PCI_Reg: A4h]			
Field Name	Bits	Default	Description
GPIO_Status	15:0	----	When the IDE bus is used as GPIO, these are the read ports for each IDE data bit when IDE bus is configured as GPIOs
IDE_GPIO_In register			

GPIO_48_47_46_37_Cntrl - RW – 16 bits - [PCI_Reg: A6h]			
Field Name	Bits	Default	Description
GPIO_Out	3:0	0h	Write 1 to set and 0 to clear each of the GPIO port providing the corresponding bits [7:4] and [15:12] are enabled Bit [0] for GPIO37 Bit [1] for GPIO46/AZ_SDIN3 Bit [2] for GPIO47/SPI_CLK Bit [3] for GPIO48/FANOUT1
GPIO_Out_En#	7:4	Fh	GPIO output port enable for each of the GPIO port 0: Output = GPIO_Out 1: Output = tristate
GPIO_Status	11:8	-	GPIO input status for each of the GPIO port
GPIO_Enable	15:12	0h	GPIO function enable for each of the GPIO port 0: GPIO disabled 1: GPIO enabled Bit[13] [15] no effect Use PM_Reg: 60h bit [2] to configure GPIO48/FANOUT1.
GPIO_48_47_46_37_Cntrl register			

GPIO_12_to_4_Cntrl – RW – 32 bits - [PCI_Reg: A8h]			
Field Name	Bits	Default	Description
GPIO_Out	7:0	00h	Write 1 to set and 0 to clear each of the GPIO port providing the corresponding bits [15:8], [25], [31:30] are enabled Output for GPIO[12:11][9:4] Bit [0] for GPIO4/SMARTVOLT Bit [1] for GPIO5/SHUTDOWN/SMARTVOLT2 Bit [2] for GPIO6/GNI# Bit [3] for GPIO7/VGATE Bit [4] for GPIO8/DDC1_SDA Bit [5] for GPIO9/DDC1_SCL Bit [6] for GPIO11/SPI_DO Bit [7] for GPIO12/SPI_DI
GPIO_Out_En#	15:8	FFh	GPIO output port enable for each of the GPIO port 0: Output = GPIO_Out 1: Output = tristate
GpioIn	23:16	-	GPIO input status for each of the GPIO port
GPIO10_Out	24	0b	Write 1 to set and 0 to clear GPIO10/SATA_ISO#
GPIO10_Out_En#	25	1b	GPIO output port enable for GPIO10/SATA_ISO# 0: Output = GPIO10_Out 1: Output = tristate
GPIO10_Status	26	-	GPIO input status for GPIO10/SATA_ISO#
Reserved	29:27	000b	
GPIO_Enable	31:30	0h	GPIO function enable for GPIO[12:11] 0: GPIO disabled 1: GPIO enabled
GPIO_12_to_4_Cntrl register			

SATA_ACT_GPIO_Cntrl - RW – 8 bits - [PCI_Reg: ACh]			
Field Name	Bits	Default	Description
GPIO67_Out	0	0b	Write 1 to set and 0 to clear GPIO67/SATA_ACT#
GPIO67_Out_En#	1	1b	GPIO output port enable for GPIO67/SATA_ACT# 0: Output = GPIO67_Out 1: Output = tristate
GPIO67_Status	2	-	GPIO input status for GPIO67/SATA_ACT#
GPIO67_Enable	3	0b	GPIO function enable for GPIO67/SATA_ACT# 0: GPIO disabled 1: GPIO enabled
SMI_CMD_action	4	1b	If this bit is enabled, then SMI_CMD or SLP_trap will cause SMI to be sent to the host regardless of EOS status. Otherwise SMI is sent only when EOS=1.
Reserved	7:5		
SATA_ACT_GPIO_Cntrl register			

SATA Enable- RW – 8 bits - [PCI_Reg: ADh]			
Field Name	Bits	Default	Description
SataEnable	0	1b	SATA enable
SataSmbusEn#	1	0b	SATA SMBus enable; set to 1 to disable. SATA controller contains a smbus slave controller which can be used to program the SATA PHY circuitry. This is used for testing/characterization purpose
SataSmbusMode	2	0b	SATA SMBus mode. Set to 1 to put SATA I2C on GPIO pins, and use external I2C master to talk to the Sata I2C target. Set to 0 to use on-chip SMBUS as I2C master to talk to the Sata I2C target. Sata I2C interface is only used for characterization purpose.
CombinedMode	3	1b	Set SATA and IDE controller into combined mode.

SATA Enable- RW – 8 bits - [PCI_Reg: ADh]			
Field Name	Bits	Default	Description
ChannelSel	4	0b	Set SATA/PATA controller to be primary or secondary channel select 0: SATA is primary, PATA is secondary 1: PATA is primary, SATA is secondary
Disable link latency enhancement	5	1b	When cleared, an enhancement of SATA link latency will be enabled. This bit only takes effect in A14 or above. It is a reserved bit in A12.
Reserved	6	0b	
HiddenMsiEnable	7	0b	Setting this bit will cause PCI_Reg:B0h, bit [16] to read 1
SATA Enable register			

Misc Control - RW – 8 bits - [PCI_Reg: AEh]			
Field Name	Bits	Default	Description
ExtendIntrToWakeTime	2:0	000b	This is used in K8 system to extend the interrupt break event status. Whenever there is an apic interrupt, this logic will extend the break event status by the amount of time defined by this register. This is to avoid potential race condition between CPU issuing the C1e command and the SB seeing an interrupt. If CPU tries to enter C state before the extension time expires, SB will break out from the C state. Each count represents 2 microsecond increment and it has an uncertainty of 2 microseconds.
HiddenIDE	3	0b	Setting this bit will hide IDE(PATA) controller.
Ioapic_id_ext_en	4	0b	Extend IOAPIC ID from 4-bit to 8-bit.
Reserved	5	0b	
IoApicPicArbEn	6	0b	Set to 1 to enable arbiter between IoApic and Pic interrupt message.
Reserved	7	0b	
Misc Control register			

SataIntMap - RW – 8 bits - [PCI_Reg: AFh]			
Field Name	Bits	Default	Description
Reserved	0		
BlockImcAccessOnHost	1		Set to 1 to force IMC to wait for all the transactions of the sm master, and for the slave to idle before sm Hc processes the IMC request.
SataIntMap	4:2	000b	SATA interrupt mapping to PCI interrupt 000: INTA# 001: INTB# 010: INTC# 011: INTD# 100: INTE# 101: INTF# 110: INTG# 111: INTH#
Reserved	7:5		
SataIntMap register			

MSI Mapping Capability - R - 32 bits - [PCI_Reg: B0h]			
Field Name	Bits	Default	Description
Capability ID	7:0	08h	This is a HyperTransport™ capability list item.
Capability Pointer	15:8	00h	This is the end of capability list.
MsiEnable	16	0b	MSI enable programmable through PCI_Reg: ADh bit 7 (used with HPET MSI)

MSI Mapping Capability - R - 32 bits - [PCI_Reg: B0h]			
Field Name	Bits	Default	Description
Fixed	17	1b	The address for mapping MSIs is fixed at 0000_0000_FEEh_xxxxh.
Reserved	26:18		
Capability Type	31:27	1010_1b	This is an MSI Mapping Capability block.
MSI Mapping Capability register			

Base Address 1- R - 32 bits - [PCI_Reg: B4h]			
Field Name	Bits	Default	Description
Reserved	9:0	000h	Hardwired to 0. Memory map only
HPETBaseAddr	31:10	000000h	High Precision Event Timer (also called Multi-media Timer) base address.
Base Address 1 register			

PCI_INT_GPIO_Cntrl - RW - 16 bits - [PCI_Reg: BCh]			
Field Name	Bits	Default	Description
PciIntGpioOut	3:0	0h	Output data for each PCI INT# GPIO providing bits [7:4] and [15:12] are enabled
PciIntGpioEnB	7:4	Fh	Output enable for each PCI INT# GPIO (active low)
PciIntGpioStatus	11:8	-	Input status for each PCI INT# GPIO [Read Only]
PciIntIsGpio	15:12	0h	Set to 1 to use PCI interrupt INT#G/F/E# as GPIO
PCI_INT_GPIO_Cntrl register			

UsbIntMap - RW - 16 bits - [PCI_Reg: BEh]			
Field Name	Bits	Default	Description
UsbInt1Map	2:0	000b	UsbInt1 interrupt mapping to PCI interrupt
UsbInt2Map	5:3	001b	UsbInt2 interrupt mapping to PCI interrupt
Reserved	7:6	00b	
UsbInt3Map	10:8	010b	UsbInt3 interrupt mapping to PCI interrupt
UsbInt4Map	13:11	011b	UsbInt4 interrupt mapping to PCI interrupt
Reserved	15:14	00b	
Encoding: 000: INTA# 001: INTB# 010: INTC# 011: INTD# 100: INTE# 101: INTF# 110: INTG# 111: INTH# The Interrupt mapping from USB controllers to Interrupt controller is as following, USB1(device-18) : OHCI0(fun-0)/OHCI1(fun-1) – UsbInt1 EHCI (fun-2) – UsbInt2 USB2(device-19) : OHCI0(fun-0)/OHCI1(fun-1) – UsbInt3 EHCI (fun-2) – UsbInt4			

IO Drive Strength - RW - 32 bits - [PCI_Reg: C0h]			
Field Name	Bits	Default	Description
IoDrvSth_AD	2:0	111b	IO drive strength for PCI signals: AD[31:0], CBE0#, CBE1#, CBE2#, CBE3#, PAR, A_RST#, FRAME#, IRDY#, DEVSEL#, TRDY#, LOCK#, STOP#, PERR#, SERR#, CLKRUN# and PCIRST# pads.
IoDrvSth_GNT	5:3	111b	IO drive strength for AGNT#[4:0] pads
IoDrvSth_ClkGrpA	8:6	111b	IO drive strength for PCICLK0 pad
IoDrvSth_ClkGrpB	11:9	111b	IO drive strength for PCICLK[4:1] pads. The recommended setting for single load is 000b.

IO Drive Strength - RW - 32 bits - [PCI_Reg: C0h]			
Field Name	Bits	Default	Description
IoDrvSth_LPC	14:12	111b	IO drive strength for LPC LAD, LFRAME# pads are controlled by bit 12 only: Bit 12 =0: 50% Bit 12 =1: 100% LDrq[1:0] are controlled by bit 14:12; refer to note below for detailed drive strength.
IoDrvSth_Int	17:15	111b	IO drive strength for INTA#, INTB#, INTC#, INTD#, INTE#, INTF#, INTG# and INTH# pads
IoDrvSth_Req	20:18	111b	IO drive strength for REQ[3:0]# when they are configured as GPIO
IoDrvSth_GpioA	23:21	111b	IO drive strength for BMREQ#, GPIO[0, 2, 4, 5, 7, 8, 9, 13, 37, 38, 39, 40], GPOC[0, 1] pads
IoDrvSth_GpioB	26:24	111b	IO drive strength for GPIO3, and GPIO[48:52] pads
IoDrvSth_Misc	29:27	111b	IO drive strength for GA20, KBRST#, SERIRQ and SATA_ACT# pads
IoDrvSth_IDE	31:30	11b	IO drive strength for IDE interface
IO Drive Strength: Each three bit field controls the number of P and N transistors enabled in the final stage of the output driver for the designated pads. By controlling the number of transistors enabled, the designer can optimize the drive characteristics of signals based on the topology of their specific design.			

Note: Table 2-3 below shows the recommended drive strength levels for different interfaces represented by Bits [2:0] , [5:3] , [8:6], [11:9], [14:12], [17:15], [20:18], [23:21], [26:24], and [29:27] based on empirical data collected from a live system. Table 2-4 shows the recommendations for the IDE interface (for Bits [31:30]).

Table 2-3: IO Drive Strength Recommendations for Various Interfaces

S2	S1	S0	Percent Drive Strength	Loads
0	0	0	33%	For 0-1 loads
0	0	1	44%	For 2 loads
0	1	0	55%	For 3-4 loads
0	1	1	66%	For 4-5 loads

Table 2-4: IO Drive Strength Recommendations for the IDE Interface

S1	S0	Percent Drive Strength
0	0	75%
0	1	100%
1	0	100%
1	1	110%

I2CbusConfig - RW - 8 bits - [PCI_Reg: D2h]			
Field Name	Bits	Default	Description
I2CController Enable	0	0b	I2C controller host interface enable
I2CbusInterrupt	1	0b	0: SMI# 1: IRQ

I2CbusConfig - RW - 8 bits - [PCI_Reg: D2h]			
Field Name	Bits	Default	Description
Reserved	5:2		
SmbusSel2	6	0b	Enables IMC GPIO 11/12 as Smbus Clk/Data
SmbusSel3	7	0b	Enables IMC GPIO 13/14 as Smbus Clk/Data
I2CbusConfig register: Registers D2-D5 control the interface when this chip is the I2C slave.			

I2CCommand - RW - 8 bits - [PCI_Reg: D3h]			
Field Name	Bits	Default	Description
I2Ccommand	7:0	00h	I2C Host Slave Command; this value specifies the command value to be matched for I2C master accesses to the I2Ccontroller host slave interface.
I2CCommand register			

I2CShadow1- RW - 8 bits - [PCI_Reg: D4h]			
Field Name	Bits	Default	Description
Read/Write ShadowPort1	0	0b	Read/Write for Shadow Port 1 This bit must be programmed to 0 because I2C slave controller only responds to Word Write Transaction.
I2CslaveAddr1	7:1	00h	SMBus Slave Address for shadow port 1 This value specifies the address used to match against incoming I2C addresses for Shadow port 1.
I2CShadow1 register			

I2Cshadow2- RW - 8 bits - [PCI_Reg: D5h]			
Field Name	Bits	Default	Description
Read/Write ShadowPort2	0	0b	Read/Write for Shadow Port 2 This bit must be programmed to 0 because I2C slave controller only responds to Word Write Transaction.
I2CslaveAddr2	7:1	00h	SMBus Slave Address for shadow port 2 This value specifies the address used to match against incoming I2C addresses for Shadow port 2.
I2Cshadow2 register			

I2CbusRevision - R - 8 bits - [PCI_Reg: D6h]			
Field Name	Bits	Default	Description
I2CbusRevision	7:0	00h	Revision ID
I2CbusRevision register			

MSI Weight - RW – 8 bits - [PCI_Reg: E0h]			
	Bits	Default	Description
MSI_weight	5:0	100000b	Used by the BIOS to tune MSI messaging priority (MSI is used by HPET)
Reserved	7:6	00b	
MSI Weight register			

Misce1 Weight - RW – 8 bits - [PCI_Reg: E1h]			
	Bits	Default	Description
SMEEn	0	1b	Enables the SM slave machine. SW has to set the bit to 1 all the time.
WaitForIdle_MMio	1	1b	Set to 1 to force MMio cycle to wait for master cycles to finish before starting. SW has to set the bit to 1 all the time.
Emulate64	2	0b	Set to 1 to let Acpi sm Hc to control Usb legacy support.
INTAFix	3	0b	Set to 1 to fix an INTA timing issue. SW has to set the bit to 1 all the time.

MiscE1 Weight - RW – 8 bits - [PCI_Reg: E1h]			
	Bits	Default	Description
AllowSm0Kill	4	0b	Set to 1 to allow Host to set kill bit even Smbus0 is idle. SW has to set the bit to 1 all the time.
ImcHostSmArbEn	5	0b	Set to 1 to arbitrate SMBus access between IMC request and Host request. SW has to set the bit to 1 all the time.
CirLevelConfig	6	0b	Set to 1 to treat Cir interrupt as level signal (Active low)
BlockMasterImc	7	0b	Block Sm master request if IMC is accessing Sm Hc. SW has to set the bit to 1 all the time.
MiscE1			

AB_REG_BAR - RW - 32 bits - [PCI_Reg: F0h]			
Field Name	Bits	Default	Description
AB_REG_BAR	31:0	0000_000 0h	Base Address for A-link Bridge Register
AB_REG_BAR register			

Wake IO Addr- RW - 16 bits - [PCI_Reg: F4h]			
Field Name	Bits	Default	Description
WakeloAddr	15:0	0000h	IO Address for C-State Wake-up by CPU (K8 only). The BIOS can program an address inside K8 and this location. The K8 can then use it to generate an IO write to tell SB to wake from C state
Wake IO Addr register			

Extended Addr Port- RW - 32 bits - [PCI_Reg: F8h]			
Field Name	Bits	Default	Description
ExtendedAddrPort	31:0	00h	Address port for the extended register block
Extended Addr Port register			

Extended Data Port- RW - 32 bits - [PCI_Reg: FCh]			
Field Name	Bits	Default	Description
ExtendedDataPort	31:0	00h	Data port for the extended register block
Extended Data Port register			

2.3.1.2 Extended Registers

Register Name	Configuration Offset
Audio Port Config	00h
Audio GPIO Control	04h

Audio Port Config- RW - 32 bits - [Extend_Reg: 00h]			
Field Name	Bits	Default	Description
AzPort0Config	1:0	01b	Port configuration for HD Audio input port: 00 or 11: GPIO port 01: Undefined 10: Set as HD Audio port
AzPort1Config	3:2	01b	Port configuration for HD Audio input port: 00 or 11: GPIO port 01: Undefined 10: Set as HD Audio port
AzPort2Config	5:4	10b	Port configuration for HD Audio input port: 00 or 11: GPIO port 01: Undefined 10: Set as HD Audio port
AzPort3Config	7:6	10b	Port configuration for HD Audio input port: 00 or 11: GPIO port 01: Undefined 10: Set as HD Audio port
AudioPortLock	8	0b	When this bit is set, bits [7:0] are locked and become read-only. Only way this bit can be reverted to 1 is by system reset 1: All AzPort*Config bits become locked and become read only 0: All AzPort*Config bits are R/W
Reserved	15:9		
AudioGpioIn0Status	16	-	When ACZ_SDIN0 is configured as GPIO, this bit returns the GPIO input status.
AudioGpioIn1Status	17	-	When ACZ_SDIN 1 is configured as GPIO, this bit returns the GPIO input status.
AudioGpioIn2Status	18	-	When ACZ_SDIN 2 is configured as GPIO, this bit returns the GPIO input status.
AudioGpioIn3Status	19	-	When ACZ_SDIN 3 is configured as GPIO, this bit returns the GPIO input status.
AzRstGpioIn	20	-	When AZ_RST# is configured as GPIO, this bit returns the GPIO input status.
Reserved	23:21		
AzRstGpioIn	24	-	When AZ_RST# is configured as GPIO, this bit returns the GPIO input status.
AzBclkGpioIn	25	-	When AZ_BitClk is configured as GPIO, this bit returns the GPIO input status.
Gpio[40]In	26	-	This bit returns the GPIO40 input status.
Gpio[39]In	27	-	This bit returns the GPIO39 input status.
Gpio[41]In	27	-	This bit returns the GPIO41 input status.
Reserved	31:29	000b	
Audio Port Config register			

Audio GPIO Control – RW - 32 bits - [Extend_Reg: 04h]			
Field Name	Bits	Default	Description
AudioGpioOut0OeB	0	1b	When ACZ_SDIN0 is configured as GPIO, this bit represents the output enable. 1: Tristate 0: Enable

Audio GPIO Control – RW - 32 bits - [Extend_Reg: 04h]			
Field Name	Bits	Default	Description
AudioGpioOut1OeB	1	1b	When ACZ_SDIN1 is configured as GPIO, this bit represents the output enable. 1: Tristate 0: Enable
AudioGpioOut2OeB	2	1b	When ACZ_SDIN2 is configured as GPIO, this bit represents the output enable. 1: Tristate 0: Enable
AudioGpioOut3OeB	3	1b	When ACZ_SDIN3 is configured as GPIO, this bit represents the output enable. 1: Tristate 0: Enable
AzRstGpioOutOeB	4	1b	When AZ_RST# is configured as GPIO, this bit represents the output enable. 1: Tristate 0: Enable
Reserved	7:5		
AzRstGpioOutOeB	8	1b	When AZ_RST# is configured as GPIO, this bit represents the output enable. 1: Tristate 0: Enable
AzBclkGpioOeB	9	1b	When AZ_BitClk is configured as GPIO, this bit represents the output enable. 1: Tristate 0: Enable
Gpio40OeB	10	1b	When GPIO40 is configured as GPIO, this bit represents the output enable. 1: Tristate 0: Enable
Gpio39OeB	11	1b	When GPIO39 is configured as GPIO, this bit represents the output enable. 1: Tristate 0: Enable
Gpio41OeB	12	1b	When GPIO41 is configured as GPIO, this bit represents the output enable. 1: Tristate 0: Enable
Reserved	15:13	001b	
AudioGpioOut0	16	0b	When AZ_SDIN 0 is configured as GPIO, this bit represents the output value if the output is enabled. 1: High 0: Low
AudioGpioOut1	17	0b	When AZ_SDIN 1 is configured as GPIO, this bit represents the output value if the output is enabled. 1: High 0: Low
AudioGpioOut2	18	0b	When AZ_SDIN 2 is configured as GPIO, this bit represents the output value if the output is enabled. 1: High 0: Low
AudioGpioOut3	19	0b	When AZ_SDIN 3 is configured as GPIO, this bit represents the output value if the output is enabled. 1: High 0: Low
AzRstGpioOut	20	0b	When AZ_RST# is configured as GPIO, this bit represents the output value if the output is enabled. 1: High 0: Low
Reserved	23:21	000b	

Audio GPIO Control – RW - 32 bits - [Extend_Reg: 04h]			
Field Name	Bits	Default	Description
AzRstGpioOut	24	0b	When AZ_RST# is configured as GPIO, this bit represents the output value if the output is enabled. 1: High 0: Low
AzBclkGpioOut	25	0b	When AZ_BitClk is configured as GPIO, this bit represents the output value if the output is enabled. 1: High 0: Low
Gpio40Out	26	0b	When GPIO40 is configured as GPIO, this bit represents the output value if the output is enabled. 1: High 0: Low
Gpio39Out	27	0b	When GPIO39 is configured as GPIO, this bit represents the output value if the output is enabled. 1: High 0: Low
Gpio41Out	28	0b	When GPIO41 is configured as GPIO, this bit represents the output value if the output is enabled.
Reserved	31:29	000b	
Audio GPIO Control register			

2.3.2 SMBus Registers

Register Name	Offset Address
SMBusStatus	00h
SMBusSlaveStatus	01h
SMBusControl	02h
SMBusHostCmd	03h
SMBusAddress	04h
SMBusData0	05h
SMBusData1	06h
SMBusBlockData	07h
SMBusSlaveControl	08h
SMBusShadowCmd	09h
SMBusSlaveEvent	0A-0Bh
SlaveData	0C-0Dh
SMBusTiming	0Eh

Note: The SMBus registers are located at the IO memory space base address defined by PCI configuration register 90-93h

SMBusStatus - RW - 8 bits - [SMBUS:00h]			
Field Name	Bits	Default	Description
HostBusy	0	0b	This bit indicates the SMBus controller is in the process of completing a command. When this bit is set, software should not access any other SMBus registers [Read-only]
SMBusInterrupt	1	0b	This bit is set by hardware to indicate the completion of the last host command. This bit can be cleared by writing an 1 to it.
DeviceErr	2	0b	This bit is set by hardware to indicate an error of one of the following: (1) illegal command field, (2) unclaimed cycle, (3) host device time-out. This bit can be cleared by writing an 1 to it.
BusCollision	3	0b	This bit is set by hardware to indicate SMBus transaction collision; this bit can be cleared by writing an 1 to it.

SMBusStatus - RW - 8 bits - [SMBUS:00h]			
Field Name	Bits	Default	Description
Failed	4	0b	This bit is set by hardware to indicate a failed bus transaction, set when SMBusControl.Kill bit is set. This bit is cleared by writing an 1 to it
Reserved	7:5	000b	

SMBusSlaveStatus - RW - 8 bits - [SMBUS:01h]			
Field Name	Bits	Default	Description
SlaveBusy	0	0b	This bit indicates the SMBus controller slave interface is in the process of receiving data. Software should not try to access any other SMBus register when this bit is set. [Read-only]
SlaveInit	1	0b	Writing a 1 to this bit will initialize the slave. It is unnecessary to write it back to 0. A read from it will always return a 0.
SlaveStatus	2	0b	This bit is set by hardware to indicate a slave cycle event match of the SMBus slave command and SMBus Slave Event match. This bit can be cleared by writing an 1 to it.
Shadow1Status	3	0b	This bit is set by hardware to indicate a slave cycle address match of the SMB_Shadow1 port. This bit can be cleared by writing a 1 to it.
Shadow2Status	4	0b	This bit is set by hardware to indicate a slave cycle address match of the SMB_Shadow2 port. This bit can be cleared by writing a 1 to it.
AlertStatus	5	0b	This bit is set by hardware to indicate SMBALERT_ signal. This function is not supported. [Read-only]
Reserved	7:6	00b	

SMBusControl - RW - 8 bits - [SMBUS:02h]			
Field Name	Bits	Default	Description
InterruptEnable	0	0b	Enables the generation of interrupts on the completion of current host transaction.
Kill	1	0b	Stop the current host transaction in process
SMBusProtocol	4:2	000b	000: Quick Read or Write 001: Byte Read or Write 010: Byte Data Read or Write 011: Word Data Read or Write 100: Reserved 101: Block Read or Write 110: Reserved 111: Reserved
Reserved	5	0b	
Start	6	0b	Writing an 1 in this field initiates SMBus controller host interface to execute the command programmed in the SMBusProtocol field
Reserved	7	0b	

SMBusHostCmd - RW - 8 bits - [SMBUS:03h]			
Field Name	Bits	Default	Description
SMBusHostCmd	7:0	00h	This field contains the data transmitted in the command field of SMBus host transaction

SMBusAddress - RW - 8 bits - [SMBUS:04h]			
Field Name	Bits	Default	Description
SMBusRdWr	0	0b	1: Execute a Read command 0: Execute a Write command
SMBusAddr	7:1	00h	This field contains the 7-bit address of the target slave device.

SMBusData0 - RW - 8 bits - [SMBUS:05h]			
Field Name	Bits	Default	Description
SMBusData0	7:0	00h	This register should be programmed with a value to be transmitted in the data 0 field of an SMBus host interface transaction. For Block Write commands, the count of the memory should be stored in this field. The value of this register is loaded into the block transfer count field. This valid value for block command count is between 1 and 32. For block reads, count received from SMBus device is stored here.

SMBusData1 - RW - 8 bits - [SMBUS:06h]			
Field Name	Bits	Default	Description
SMBusData1	7:0	00h	This register should be programmed with a value to be transmitted in the data 1 field of an SMBus host interface transaction.

SMBusBlockData - RW - 8 bits - [SMBUS:07h]			
Field Name	Bits	Default	Description
SMBusBlockData	7:0	00h	This register is used to transfer data into or out of the block data storage array.

SMBusSlaveControl - RW - 8 bits - [SMBUS:08h]			
Field Name	Bits	Default	Description
SlaveEnable	0	0b	Enables the generation of an interrupt or resume event upon an external SMBus master generating a transaction with an address that matches the host controller slave port of 10h and a command field which matches the SMBus slave control register and a match of corresponding enabled events.
SMBusShadow1En	1	0b	Enables the generation of an interrupt or resume event upon an external SMBus master generating a transaction with an address that matches the SMBus Shadow 1 register.
SMBusShadow2En	2	0b	Enables the generation of an interrupt or resume event upon an external SMBus master generating a transaction with an address that matches the SMBus Shadow 2 register.
SMBusAlertEnable	3	0b	Enables the generation of an interrupt or resume event on the assertion of AMBALERT_ signal_ (This function is not supported). [Read-only]
HostSemaphore	4	0b	Bits [4] and [6] are meant to be used as software semaphore between the host and the integrated Micro-controller (IMC). When both host and IMC want to use the same resource, they can write to these semaphore bits first, then follow by a read. If the read returns an 1 in the semaphore bit, it means it has establish the semaphore first. Write 1 to set this bit. This bit can only be set when ImcSemaphore is clear. Write 0 has no effect. Read returns the value of this bit
ClrHostSemaphore	5	0b	Write 1 to clear HostSemaphore bit. Write 0 has no effect and read always returns 0
ImcSemaphore	6	0b	Write 1 to set this bit. This bit can only be set when HostSemaphore is clear. Write 0 has no effect. Read returns the value of this bit
ClrImcSemaphore	7	0b	Write 1 to clear ImcSemaphore bit. Write 0 has no effect and read always returns 0

SMBusShadowCmd - RW - 8 bits - [SMBUS:09h]			
Field Name	Bits	Default	Description
SMBusShadowCmd	7:0	00h	This field contains the command value which was received during an external SMBus master access whose address field matched the host slave address (10h) or one of the slave shadow ports.

SMBusSlaveEvent - RW - 16 bits - [SMBUS:0A-0Bh]			
Field Name	Bits	Default	Description
SMBusSlaveEvent	15:0	0000h	This field contains data bits used to compare against incoming data to the SMBus Slave Data register. When a bit in this register is 1 and a corresponding bit in SMBus Slave register is set, then an interrupt or resume event is generated if the command value matches the value in the SMBus slave control register and the access was to SMBus host address 10h.

SlaveData - RW - 16 bits - [SMBUS:0C-0Dh]			
Field Name	Bits	Default	Description
SlaveData	15:0	0000h	This field contains the data value which was transmitted during an external SMBus master access whose address field matched one of the slave shadow port addresses or the SMBus host controller slave port address of 10h.

SMBusTiming - RW - 8 bits - [SMBUS:0Eh]			
Field Name	Bits	Default	Description
SMBusTiming	7:0	B0h	This register controls the frequency on the SMBUS. The formula to calculate the frequency is as follows: Frequency = 66Mhz/(SmBusTiming * 4)

2.3.3 Legacy ISA and ACPI Controller

2.3.3.1 Legacy Block Registers

There are two sets of registers in the ACPI/SMBus module. The first set is in the PCI configuration space and the registers control the behavior of the PCI interface. The second set is in the Memory/IO mapped address space. These registers control the functions of the module; namely the legacy functions such as DMA, timers, PIC, interrupt routing for PIC, RTC, and the SP5100 specific control registers.

2.3.3.1.1 IO-Mapped Control Registers

Register Name	Offset Address
Dma_Ch 0	00h
Dma_Ch 1	02h
Dma_Ch 2	04h
Dma_Ch 3	06h
Dma_Status	08h
Dma_WriteRequest	09h
Dma_WriteMask	0Ah
Dma_WriteMode	0Bh
Dma_Clear	0Ch
Dma_MasterClr	0Dh
Dma_ClrMask	0Eh
Dma_AllMask	0Fh
IntrCntrlReg1	20h
IntrCntrlReg2	21h
TimerCh0	40h

Register Name	Offset Address
TimerCh1	41h
TimerCh2	42h
Tmr1CntrlWord	43h
Nmi_Status	61h
Nmi_Enable	70h
RtcDataPort	71h
AlternatRtcAddrPort	72h
AlternatRtcDataPort	73h
Dma_PageCh2	81h
Dma_PageCh3	82h
Dma_PageCh1	83h
Dma_Page_Reserved1	84h
Dma_Page_Reserved2	85h
Dma_Page_Reserved3	86h
Dma_PageCh0	87h
Dma_Page_Reserved4	88h
Dma_PageCh6	89h
Dma_PageCh7	8Ah
Dma_PageCh5	8Bh
Dma_Page_Reserved5	8Ch
Dma_Page_Reserved6	8Dh
Dma_Page_Reserved7	8Eh
Dma_Refresh	8Fh
FastInit	92h
IntrCntrl2Reg1	A0h
IntrCntrl2Reg2	A1h
Dma2_Ch4Addr	C0h
Dma2_Ch4Cnt	C2h
Dma2_Ch5Addr	C4h
Dma2_Ch5Cnt	C6h
Dma2_Ch6Addr	C8h
Dma2_Ch6Cnt	CAh
Dma2_Ch7Addr	CCh
Dma2_Ch7Cnt	CEh
Dma_Status	D0h
Dma_WriteRequest	D2h
Dma_WriteMask	D4h
Dma_WriteMode	D6h
Dma_Clear	D8h
Dma_Clear	DAh
Dma_ClrMask	DCh
Dma_ClrMask	DEh
NCP_Error	F0h
DMA1_Extend	40Bh
IntrEdgeControl	4D0h
DMA2_Extend	4D6h
Pci_Intr_Index	C00h
Pci_Intr_Data	C01h
Pci_Error	C14h
CMIndex	C50h
CMData	C51h
GpmPort	C52h
Isa_Misc	C6Fh
PM2_Index	CD0h
PM2_Data	CD1h
BIOSRAM_Index	CD4h
BIOSRAM_Data	CD5h
PM_Index	CD6h

Register Name	Offset Address
PM_Data	CD7h

Note: The PCI I/O registers are 32-bit registers decoded from the full 32-bit PCI address and C/BE[3:0]#. Therefore, the bytes within a 32-bit address are selected with the valid byte enables. Registers and bits within a register marked as reserved are not implemented. Writes have no effect on reserved registers. All PCI I/O registers can be accessed via 8, 16, or 32-bit cycles (i.e., each byte is individually selected by the byte enables).

Dma_Ch 0- RW – 16 bits - [IO_Reg: 00h]			
Field Name	Bits	Default	Description
Dma_Ch 0	15:0	0000h	DMA1 Ch0 Base and Current Address
Dma_Ch 0 register			

Dma_Ch 1- RW – 16 bits - [IO_Reg: 02h]			
Field Name	Bits	Default	Description
Dma_Ch 1	15:0	0000h	DMA1 Ch1 Base and Current Address
Dma_Ch 1 register			

Dma_Ch 2- RW – 16 bits - [IO_Reg: 04h]			
Field Name	Bits	Default	Description
Dma_Ch 2	15:0	0000h	DMA2 Ch2 Base and Current Address
Dma_Ch 2 register			

Dma_Ch 3- RW – 16 bits - [IO_Reg: 06h]			
Field Name	Bits	Default	Description
Dma_Ch 3	15:0	0000h	DMA1 Ch3 Base and Current Address
Dma_Ch 3 register			

Dma_Status- RW – 8 bits - [IO_Reg: 08h]			
Field Name	Bits	Default	Description
Dma_Status	7:0	00h	Returns status when read; command for write
Dma_Status register			

Dma_WriteRequest- RW – 8 bits - [IO_Reg: 09h]			
Field Name	Bits	Default	Description
Dma_WriteRequest	7:0	00h	Request register.
Dma_WriteRequest register			

Dma_WriteMask- RW – 8 bits - [IO_Reg: 0Ah]			
Field Name	Bits	Default	Description
Dma_WriteMask	7:0	00h	Channel mask register.
Dma_WriteMask register			

Dma_WriteMode- RW – 8 bits - [IO_Reg: 0Bh]			
Field Name	Bits	Default	Description
Dma_WriteMode	7:0	00h	Mode register.
Dma_WriteMode register			

Dma_Clear- RW – 8 bits - [IO_Reg: 0Ch]			
Field Name	Bits	Default	Description
Dma_Clear	7:0	00h	Channel 0-3 DMA clear byte pointer

Dma_Clear- RW – 8 bits - [IO_Reg: 0Ch]			
Field Name	Bits	Default	Description
Dma_Clear register			

Dma_MasterClr- RW – 8 bits - [IO_Reg: 0Dh]			
Field Name	Bits	Default	Description
Dma_MasterClr	7:0	00h	Intermediate register.
Dma_MasterClr register			

Dma_ClrMask- RW – 8 bits - [IO_Reg: 0Eh]			
Field Name	Bits	Default	Description
Dma_ClrMask	7:0	00h	Channel 0-3 DMA Clear Mask
Dma_ClrMask register			

Dma_AllMask- RW – 8 bits - [IO_Reg: 0Fh]			
Field Name	Bits	Default	Description
Dma_AllMask	7:0	00h	Mask register.
Dma_AllMask register			

IntrCntrl1Reg1- RW – 8 bits - [IO_Reg: 20h]			
Field Name	Bits	Default	Description
IntrCntrl1Reg1	7:0	00h	IRQ0 – IRQ7: Read IRR, ISR Write ICW1, OCW2, OCW3
IntrCntrl1Reg1 register			

IntrCntrl1Reg2- RW – 8 bits - [IO_Reg: 21h]			
Field Name	Bits	Default	Description
IntrCntrl1Reg2	7:0	00h	IRQ0 – IRQ7: Read IMR Write ICW2, ICW3, ICW4, OCW1
IntrCntrl1Reg2 register			

IMCR_Index- RW – 8 bits - [IO_Reg: 22h]			
Field Name	Bits	Default	Description
IMCR_Index	7:0	00h	The IMCR is supported by two read/writeable io ports 22/23h; which are used as index and data port respectively. The actual IMCR register is located at index 70h.
IMCR_Index register			

IMCR_Data- RW – 8 bits - [IO_Reg: 23h]			
Field Name	Bits	Default	Description
IMCR_Data	7:0	00h	The IMCR is supported by two read/writeable io ports 22/23h; which are used as index and data port respectively. The actual IMCR register is located at index 70h and it is at bit 0. The actual IMCR bit can only be accessed when bit port 22 is set to 70h. Default value of IMCR is 0.
IMCR_Data register			

TimerCh0- RW – 8 bits - [IO_Reg: 40h]			
Field Name	Bits	Default	Description
TimerCh0	7:0	00h	8254 Timer 1: Counter 0 Data Port This timer is known as the System Clock timer and it is always on. It is clocked internally by OSC/12 (1.19318MHz), and asserts IRQ0 every time the timer rolls over. This timer is used for time-of-day, diskette time-out, and other system timing functions.
TimerCh0 register			

TimerCh1- RW – 8 bits - [IO_Reg: 41h]			
Field Name	Bits	Default	Description
TimerCh1	7:0	00h	8254 Timer 1: Counter 1 Data Port This timer is normally used for ISA refresh cycles and is also clocked by OSC/12 (1.19818MHz). Since this refresh function is no longer needed (we don't have an external ISA bus), it can be used as a general purpose timing function.
TimerCh1 register			

TimerCh2- RW – 8 bits - [IO_Reg: 42h]			
Field Name	Bits	Default	Description
TimerCh2	7:0	00h	8254 Timer 1: Counter 2 Data Port This is the speaker tone generator and is enabled by IO port 61H. It is clocked by OSC/12 (1.19318MHz) and directly drives the output SPKR that goes to a speaker.
TimerCh2 register			

Tmr1CntrlWord - RW – 8 bits - [IO_Reg: 43h]			
Field Name	Bits	Default	Description
CntDownSelect	0	0b	0: Binary countdown 1: BCD countdown
ModeSelect	3:1	000b	000: Asserts OUT signal at end of count 001: Hardware re-triggerable one-shot 010: Rate generator 011: Square wave output 100: Software triggered strobe 101: Hardware triggered strobe 110 – 111: Not used
CommandSelect	5:4	00b	00: Counter latch command 01: Read/write least significant byte 10: Read/write most significant byte 11: Read/write least, and then most significant byte
CounterSelect	7:6	00b	00: Select counter 0 01: Select counter 1 10: Select counter 2 11: Read back command
<p>Tmr1CntrlWord register: This is the control word to access the 8254 timer 1. It is used to select which counter will be accessed and how it will be accessed. This register specifies the counter, the operating mode, the order and size of the count value, and whether it counts down in a 16 bit or BCD format.</p> <p>If a counter is programmed to read or write two-byte counts, the following precaution applies: A program must not transfer control between writing the first and second byte to another routine which also writes into that same counter; otherwise, the counter will be loaded with an incorrect value. The count must always be completely loaded with both bytes.</p>			

Nmi_Status - RW – 8 bits - [IO_Reg: 61h]			
Field Name	Bits	Default	Description
SpkrEnable	0	0b	0: Disable counter 2 1: Enable counter 2
SpkrTmrEnable	1	0b	0: Speaker timer off 1: Speaker timer on
Parity_Nmi_En	2	1b	0: Enable Parity Error to NMI generation (from SERR# or PERR#) 1: Disable Parity Error to NMI generation and clear bit 7
IoChk_Nmi_En	3	1b	0: Enable IoChk to NMI generation 1: Disable IoChk to NMI generation
RefClk	4	-	The output of the counter 1 (8254). [Read-only]
SpkrClk	5	-	The output of the counter 2. [Read-only]
IoChk_Nmi	6	-	NMI is triggered by serial IOCHK. [Read-only]
ParErr_Nmi	7	-	NMI is caused by parity error (either PERR# or SERR#). [Read-only]
Nmi_Status register: Independent read and write registers will be accessed at this port. When writing to port 61H, bits[3:0] allow software to enable/disable parity error NMI's and control the speaker timer. When reading port 61H, status on parity errors, speaker count, speaker control and refresh cycles is returned.			

Nmi_Enable - RW – 8 bits - [IO_Reg: 70h]			
Field Name	Bits	Default	Description
RTC Address Port	6:0	00h	This is used with either internal RTC or external RTC
NmiEnable	7	0b	0: NMI enable 1: NMI disable
Nmi_Enable register			

RtcDataPort - RW – 8 bits - [IO_Reg: 71h]			
Field Name	Bits	Default	Description
RTC Data Port	7:0	00h	This is used with either internal RTC or external RTC
RtcDataPort			

AlternatRtcAddrPort - RW – 8 bits - [IO_Reg: 72h]			
Field Name	Bits	Default	Description
AlternatRTCAddrPort	7:0	00h	This is used with internal RTC. This port allows user to specify the full 8 bit address (instead of bank0/bank1 indexing) to access the 256 byte RTC RAM
AlternatRtcAddrPort			

AlternatRtcDataPort - RW – 8 bits - [IO_Reg: 73h]			
Field Name	Bits	Default	Description
AlternatRTC Data Port	7:0	00h	This is used with internal RTC in conjunction with port h72
AlternatRtcDataPort			

Dma_PageCh2 - RW – 8 bits - [IO_Reg: 81h]			
Field Name	Bits	Default	Description
Dma_PageCh2	7:0	00h	DMA2 ch 2 page register
Dma_PageCh2 register			

Dma_PageCh3 - RW – 8 bits - [IO_Reg: 82h]			
Field Name	Bits	Default	Description
Dma_PageCh3	7:0	00h	DMA2 ch 3 page register
Dma_PageCh3 register			

Dma_PageCh1 - RW – 8 bits - [IO_Reg: 83h]			
Field Name	Bits	Default	Description
Dma_PageCh1	7:0	00h	DMA2 ch 1 page register
Dma_PageCh1 register			

Dma_Page_Reserved1- RW – 8 bits - [IO_Reg: 84h]			
Field Name	Bits	Default	Description
Dma_Page_Reserved1	7:0	00h	Dma Page Reserved1 register
Dma_Page_Reserved1 register			

Dma_Page_Reserved2- RW – 8 bits - [IO_Reg: 85h]			
Field Name	Bits	Default	Description
Dma_Page_Reserved2	7:0	00h	Dma Page Reserved2 register
Dma_Page_Reserved2 register			

Dma_Page_Reserved3- RW – 8 bits - [IO_Reg: 86h]			
Field Name	Bits	Default	Description
Dma_Page_Reserved3	7:0	00h	Dma Page Reserved3 register
Dma_Page_Reserved3 register			

Dma_PageCh0 - RW – 8 bits - [IO_Reg: 87h]			
Field Name	Bits	Default	Description
Dma_PageCh0	7:0	00h	DMA2 ch 0 page register
Dma_PageCh0 register			

Dma_Page_Reserved4- RW – 8 bits - [IO_Reg: 88h]			
Field Name	Bits	Default	Description
Dma_Page_Reserved4	7:0	00h	Dma Page Reserved4 register
Dma_Page_Reserved4 register			

Dma_PageCh6 - RW – 8 bits - [IO_Reg: 89h]			
Field Name	Bits	Default	Description
Dma_PageCh6	7:0	00h	DMA2 ch 6 page register
Dma_PageCh6 register			

Dma_PageCh7 - RW – 8 bits - [IO_Reg: 8Ah]			
Field Name	Bits	Default	Description
Dma_PageCh7	7:0	00h	DMA2 ch 7 page register
Dma_PageCh7 register			

Dma_PageCh5 - RW – 8 bits - [IO_Reg: 8Bh]			
Field Name	Bits	Default	Description
Dma_PageCh5	7:0	00h	DMA2 ch 5 page register
Dma_PageCh5 register			

Dma_Page_Reserved5- RW – 8 bits - [IO_Reg: 8Ch]			
Field Name	Bits	Default	Description
Dma_Page_Reserved5	7:0	00h	Dma Page Reserved5 register
Dma_Page_Reserved5 register			

Dma_Page_Reserved6- RW – 8 bits - [IO_Reg: 8Dh]			
Field Name	Bits	Default	Description
Dma_Page_Reserved6	7:0	00h	Dma Page Reserved6 register
Dma_Page_Reserved6 register			

Dma_Page_Reserved7- RW – 8 bits - [IO_Reg: 8Eh]			
Field Name	Bits	Default	Description
Dma_Page_Reserved7	7:0	00h	Dma Page Reserved7 register
Dma_Page_Reserved7 register			

Dma_Refresh- RW – 8 bits - [IO_Reg: 8Fh]			
Field Name	Bits	Default	Description
Dma_Refresh	7:0	00h	DMA2 ch4 page register.
Dma_Refresh register			

FastInit- RW – 8 bits - [IO_Reg: 92h]			
Field Name	Bits	Default	Description
FastInit	0	0b	FAST_INIT. This read/write bit provides a fast software executed processor reset function. Writing a 1 to this bit will cause the INIT assertion for approximately 4ms. Before another INIT pulse can be generated via this register, this bit must be written back to a 0.
A20EnB	1	0b	A20Enable Bar bit; if set to 1 A20M# function is disabled.

IntrCntrl2Reg1- RW – 8 bits - [IO_Reg: A0h]			
Field Name	Bits	Default	Description
IntrCntrl2Reg1	7:0	00h	IRQ8 – IRQ15: Read IRR, ISR Write ICW1, OCW2, OCW3
IntrCntrl2Reg1 register			

IntrCntrl2Reg2- RW – 8 bits - [IO_Reg: A1h]			
Field Name	Bits	Default	Description
IntrCntrl2Reg2	7:0	00h	IRQ8 – IRQ15: Read IMR Write ICW2, ICW3, ICW4, OCW1
IntrCntrl2Reg2 register			

Dma2_Ch4Addr - RW – 8 bits - [IO_Reg: C0h]			
Field Name	Bits	Default	Description
Dma2_Ch4Addr	7:0	00h	DMA2 Ch4 Base and Current Address
Dma2_Ch4Addr register			

Dma2_Ch4Cnt – RW – 8 bits - [IO_Reg: C2h]			
Field Name	Bits	Default	Description
Dma2_Ch4Cnt	7:0	00h	DMA2 Ch4 Base and Current Count
Dma2_Ch4Cnt register			

Dma2_Ch5Addr - RW – 8 bits - [IO_Reg: C4h]			
Field Name	Bits	Default	Description
Dma2_Ch5Addr	7:0	00h	DMA2 Ch5 Base and Current Address

Dma2_Ch5Addr - RW – 8 bits - [IO_Reg: C4h]			
Field Name	Bits	Default	Description
Dma2_Ch5Addr			register

Dma2_Ch5Cnt - RW – 8 bits - [IO_Reg: C6h]			
Field Name	Bits	Default	Description
Dma2_Ch5Cnt	7:0	00h	DMA2 Ch4 Base and Current Count
Dma2_Ch5Cnt register			

Dma2_Ch6Addr - RW – 8 bits - [IO_Reg: C8h]			
Field Name	Bits	Default	Description
Dma2_Ch6Addr	7:0	00h	DMA2 Ch6 Base and Current Address
Dma2_Ch6Addr register			

Dma2_Ch6Cnt - RW – 8 bits - [IO_Reg: CAh]			
Field Name	Bits	Default	Description
Dma2_Ch6Cnt	7:0	00h	DMA2 Ch6 Base and Current Count
Dma2_Ch6Cnt register			

Dma2_Ch7Addr - RW – 8 bits - [IO_Reg: CCh]			
Field Name	Bits	Default	Description
Dma2_Ch7Addr	7:0	00h	DMA2 Ch5 Base and Current Address
Dma2_Ch7Addr register			

Dma_Ch7Cnt - RW – 8 bits - [IO_Reg: CEh]			
Field Name	Bits	Default	Description
Dma2_Ch7Cnt	7:0	00h	Channel 7 DMA base and current count
Dma2_Ch7Cnt register			

Dma_Status - RW – 8 bits - [IO_Reg: D0h]			
Field Name	Bits	Default	Description
Dma_Status	7:0	00h	DMA2 status register
Dma_Status register			

Dma_WriteRequest - RW – 8 bits - [IO_Reg: D2h]			
Field Name	Bits	Default	Description
Dma_WriteRequest	7:0	00h	DMA2 request register
Dma_WriteRequest register			

Dma_WriteMask - RW – 8 bits - [IO_Reg: D4h]			
Field Name	Bits	Default	Description
Dma_WriteMask	7:0	00h	DMA2 channel mask register
Dma_WriteMask register			

Dma_WriteMode - RW – 8 bits - [IO_Reg: D6h]			
Field Name	Bits	Default	Description
Dma_WriteMode	7:0	00h	DMA2 mode register
Dma_WriteMode register			

Dma_Clear - RW – 8 bits - [IO_Reg: D8h]			
Field Name	Bits	Default	Description
Dma_Clear	7:0	00h	Channel 4-7 clear byte pointer
Dma_Clear register			

Dma_Clear - RW – 8 bits - [IO_Reg: DAh]			
Field Name	Bits	Default	Description
Dma_Clear	7:0	00h	Channel 4-7 DMA master clear
Dma_Clear register			

Dma_ClrMask - RW – 8 bits - [IO_Reg: DCh]			
Field Name	Bits	Default	Description
Dma_ClrMask	7:0	00h	Channel 4-7 DMA Clear Mask
Dma_ClrMask register			

Dma_ClrMask - RW – 8 bits - [IO_Reg: DEh]			
Field Name	Bits	Default	Description
Dma_AllMask	7:0	00h	DMA2 mask register
Dma_AllMask register			

NCP_Error - RW – 8 bits - [IO_Reg: F0h]			
Field Name	Bits	Default	Description
Reserved	6:0	00h	
WarmBoot	7	0b	Warm or cold boot indicator 0: Cold 1: Warm, this bit is set when any value is written to this register;
NCP_Error register: In addition to the WarmBoot function, writing to this port will assert IGNNE# if FERR# is true. If FERR# is false, then write to this port will not assert IGNNE#.			

DMA1_Extend - RW – 8 bits - [IO_Reg: 40Bh]			
Field Name	Bits	Default	Description
DMA1_Extend	7:0	00h	DMA1 extended write mode register
DMA1_Extend register			

IntrEdgeControl- RW – 16 bits - [IO_Reg: 4D0h]			
Field Name	Bits	Default	Description
IRQ0Control	0	0b	1: Level 0: Edge
IRQ1Control	1	0b	1: Level 0: Edge
Reserved	2	0b	
IRQ3Control	3	0b	1: Level 0: Edge
IRQ4Control	4	0b	1: Level 0: Edge
IRQ5Control	5	0b	1: Level 0: Edge
IRQ6Control	6	0b	1: Level 0: Edge
IRQ7Control	7	0b	1: Level 0: Edge
IRQ8Control	8	0b	(Read Only) Always Edge
IRQ9Control	9	0b	1: Level 0: Edge

IntrEdgeControl- RW – 16 bits - [IO_Reg: 4D0h]			
Field Name	Bits	Default	Description
IRQ10Control	10	0b	1: Level 0: Edge
IRQ11Control	11	0b	1: Level 0: Edge
IRQ12Control	12	0b	1: Level 0: Edge
Reserved	13	0b	
IRQ14Control	14	0b	1: Level 0: Edge
IRQ15Control	15	0b	1: Level 0: Edge

IntrEdgeControl register: This register programs each interrupt to be either edge or level sensitive.

DMA2_Extend - RW – 8 bits - [IO_Reg: 4D6h]			
Field Name	Bits	Default	Description
DMA2_Extend	7:0	00h	DMA2 extended write mode register

DMA2_Extend register

Pci_Intr_Index - RW – 8 bits - [IO_Reg: C00h]			
Field Name	Bits	Default	Description
Pci_Intr_Index	7:0	00h	PCI interrupt index – selects which PCI interrupt to map 0h: INTA# 1h: INTB# 2h: INTC# 3h: INTD# 4h: Interrupt generated by ACPI 5h: Interrupt generated by Sm Bus 6h: Reserved 7h: Reserved 8h: Reserved 9h: INTE# Ah: INTF# Bh: INTG# Ch: INTH#

Pci_Intr_Index register

Pci_Intr_Data - RW – 8 bits - [IO_Reg: C01h]			
Field Name	Bits	Default	Description
Pci_Intr_Data	7:0	00h	PCI redirection register; map PCI interrupt addressed by Pci_Intr_Index to a PIC IRQ [7:4]: Not used Straight encoding of [3:0] to : IRQ0 thru IRQ15 Note: Do not map to IRQ 0, 2, 8, 13 (they are reserved)

Pci_Intr_Data register
Note: If IOXAPIC is enabled, software must make sure interrupts are not re-routed; ie, they should all be set to 0. When IOXAPIC is enabled, IRQ[15:0] are routed directly to INT[15:0]. INTH#, INTG#, INTF#, INTE#, INTD#, INTC#, INTB#, and INTA# are routed to INTIN[23:16], SMBus interrupt is routed to INTIN[20], SCI# is routed to INTIN[9], and the High Precision Event Timer (also called the Multimedia Timer) can be routed to either INTIN[22] or INTIN[23].

Pci_Error - RW – 8 bits - [IO_Reg: C14h]			
Field Name	Bits	Default	Description
Serr_Nmi_Status	0	-	Set to 1 when NMI generation is enabled and SERR# has been asserted due to a PCI error. Cleared by writing a one to port 61h, bit 2. [Read-only]
Perr_Nmi_Status	1	-	Set to 1 when NMI generation is enabled and PERR# has been asserted due to a PCI data parity error. Cleared by writing a one to port 61h, bit 2. [Read-only]
Serr_Nmi	2	1b	Enable NMI generation from SERR# 0: Enable 1: Disable
Perr_Nmi	3	1b	Enable NMI generation from PERR# 0: Enable 1: Disable
Reserved	7:4	0h	
Pci_Error register			

CMIndex - RW – 8 bits - [IO_Reg: C50h]			
Field Name	Bits	Default	Description
CMIndex	7:0	00h	Index register to client management register block 00h: IdRegister 02h: TempStatus 03h: TempInterrupt 12h: SmBus control (control to Gpoc[3:0] pins thru Bit Bang) 13h: Misccontrol Others – Super IO: Not used
CMIndex register			

CMData - RW – 8 bits - [IO_Reg: C51h]			
Field Name	Bits	Default	Description
CMData	7:0	00h	Data register to client management register block
CMData register			

GpmPort - RW – 8 bits - [IO_Reg: C52h]			
Field Name	Bits	Default	Description
Gpm	7:0	--	If CMIndex.13h[7:6] = 00, then this is the read port for GPM[7:0]. If CMIndex.13h[7:6]= 01, then this is the output enable for GPM[7:0], 0=enable, 1=tristate If CMIndex.13h[7:6]=10, then this is the output state control (providing enable is turned on) If CMIndex 13h[7:6]=11, then this is the GpmLock bits. When GpmLock bit is set, the corresponding Gpm pin is locked by IMC (meaning it is solely controlled by IMC; not by BIOS). Note when this bit is locked, the corresponding PU/PD (PMIO_F7:F6) are locked as well
GpmPort register			

PM2_Index - RW – 8 bits - [IO_Reg: CD0h]			
Field Name	Bits	Default	Description
PM2_Index	7:0	00h	Power management 2 index register. This register selects one of the Power Management 2 registers.
PM2_Index register			

PM2_Data - RW – 8 bits - [IO_Reg: CD1h]			
Field Name	Bits	Default	Description
PM2_Data	7:0	00h	Power management 2 data register. This register provides the read/write access to the indexed register.
PM2_Data register			

BIOSRAM_Index - RW – 8 bits - [IO_Reg: CD4h]			
Field Name	Bits	Default	Description
BiosRamIndex	7:0	00h	BIOS RAM index register. This register selects one of the 256 bytes of BIOS RAM. Data in this RAM is preserved until RSMRST# is asserted, or S5 power is lost.)
BiosRamIndex register			

BIOSRAM_Data - RW – 8 bits - [IO_Reg: CD5h]			
Field Name	Bits	Default	Description
BiosRamData	7:0	00h	Power management data register. This register provides the read/write access to the indexed register.
BiosRamData register			

PM_Index - RW – 8 bits - [IO_Reg: CD6h]			
Field Name	Bits	Default	Description
PM_Index	7:0	00h	Power management index register. This register selects one of the Power Management registers.
PM_Index register			

PM_Data - RW – 8 bits - [IO_Reg: CD7h]			
Field Name	Bits	Default	Description
PM_Data	7:0	00h	Power management data register. This register provides the read/write access to the indexed register. (See section 2.4.3.2 for more information.)
PM_Data register			

2.3.3.1.2 Client Management Registers (Accessed through C50h and C51h)

Register Name	Offset Address
IdRegister	00h
TempStatus	02h
TempInterrupt	03h
I2Ccontrol	12h
Index13	13h

IdRegister - R – 8 bits - [IO_Reg: 00h]			
Field Name	Bits	Default	Description
IdRegister	7:0	00h	
IdRegister register			

TempStatus - R – 8 bits - [IO_Reg: 02h]			
Field Name	Bits	Default	Description
TALERT	0	-	Logical status of TALERT/GPIO64 input. Read will clear this bit.
Reserved	7:1	00h	
TempStatus register			

TempInterrupt - RW – 8 bits - [IO_Reg: 03h]			
Field Name	Bits	Default	Description
Reserved	0	0b	
TempSmiEnable	1	0b	1: Generate SMI# upon TALERT 0: Do not generate SMI# upon TALERT
Reserved	2	0b	
ScratchBit	3	0b	This placebo bit has no function, but it may be used for software status
Reserved	7:4	0h	
TempInterrupt register			

I2CControl - RW – 8 bits - [IO_Reg: 12h]			
Field Name	Bits	Default	Description
Gpoc0Status	0	-	Gpoc0 status. [Read-only]
Gpoc1Status	1	-	Gpoc1 status. [Read-only]
Gpoc0_OE_	2	1b	1: Gpoc0 is tristate 0: Gpoc0 is asserted low
Gpoc1_OE_	3	1b	1: Gpoc1 is tristate 0: Gpoc1 is asserted low
Gpoc2Status	4	-	Gpoc2 status. [Read-only]
Gpoc3Status	5	-	Gpoc3 status. [Read-only]
Gpoc2_OE_	6	1b	1: Gpoc2 is tristate 0: Gpoc2 is output enabled
Gpoc3_OE_	7	1b	1: Gpoc3 is tristate 0: Gpoc3 is output output enabled
I2CControl register: Writing to this register controls the output of the four Gpoc outputs (GPOC[3:0]_OE) and reading returns the status of these pins.			

Index13– 8 bits - [IO_Reg: 13h]			
Field Name	Bits	Default	Description
GPIO64En	0	0b	GPIO64 output enable 1: Enable 0: Tristate
GPIO64OUT	1	0b	GPIO64 output data
Gpoc[3:2]OUT	3:2	00b	Gpoc[3:2] output data
ScratchBit	5:4	00b	Placebo bit, has no function but may be used for software status
GpmPortSel	7:6	00b	00: Read port 01: Output enable 10: Output port
Index13 misc control register			

2.3.3.1.3 System Reset Register (IO CF9)

Note: Refer to PM IO reg x85 for a detailed description. This register has been designed to be dual-port accessible.

2.3.3.2 Power Management (PM) Registers

The power management (PM) block is resident in the PCI/LPC/ISA bridge. The PM registers are accessed via IO mapped registers xCD6h and xCD7h. The index address is first programmed into IO register xCD6h. Read or write values are accessed through IO register xCD7h.

Register Name	Offset Address
MiscControl	00h
MiscStatus	01h
SmiWakeUpEventEnable1	02h
SmiWakeUpEventEnable2	03h
SmiWakeUpEventEnable3	04h
SmiWakeUpEventStatus1	05h
SmiWakeUpEventStatus2	06h
SmiWakeUpEventStatus3	07h
InactiveTmrEventEnable1	08h
InactiveTmrEventEnable2	09h
InactiveTmrEventEnable3	0Ah
PmTmr1InitValue	0Bh
PmTmr1CurValue	0Ch
PwrLedExtEvent	0Dh
PwrLedExtEvent	0Eh
AcpiStatus	0Fh
AcpiEn	10h
MiscEnable11	11h
PmTmr2InitValue	12h
PmTmr2CurValue	13h
Programlo0RangeLo	14h
Programlo0RangeHi	15h
Programlo1RangeLo	16h
Programlo1RangeHi	17h
Programlo2RangeLo	18h
Programlo2RangeHi	19h
Programlo3RangeLo	1Ah
Programlo3RangeHi	1Bh
ProgramloEnable	1Ch
IOMonitorStatus	1Dh
InactiveTmrEventEnable4	1Eh
AcpiPm1EvtBlkLo	20h
AcpiPm1EvtBlkHi	21h
AcpiPm1CntBlkLo	22h
AcpiPm1CntBlkHi	23h
AcpiPmTmrBlkLo	24h
AcpiPmTmrBlkHi	25h
CpuControlLo	26h
CpuControlHi	27h
AcpiGpe0BlkLo	28h
AcpiGpe0BlkHi	29h
AcpiSmiCmdLo	2Ah
AcpiSmiCmdHi	2Bh
AcpiPm2CntBlkLo	2Ch
AcpiPm2CntBlkHi	2Dh
GEvtConfig0	30h
GEvtConfig1	31h

Register Name	Offset Address
GPMConfig0	32h
GPMConfig1	33h
GPMConfig2	34h
GPMConfig3	35h
GEvtLevelConfig	36h
GPMLevelConfig0	37h
GPMLevelConfig1	38h
GEvtStatus	39h
PMEStatus0	3Ah
PMEStatus1	3Bh
OthersConfig	3Ch
VRT_T1	3Eh
VRT_T2	3Fh
AD_Pull_UpB	40h
PM_Enable	50h
TPRESET1	51h
TPRESET2	52h
TESTENABLE	53h
PWRBTTN_CLR	54h
SoftPciRst	55h
Reserved	56h
Reserved	57h
Reserved	58h
MiscOption	59h
SmiSciSts0	5Ah
SmiSciSts1	5Bh
SmiSciSts2	5Ch
SmiSciSts3	5Dh
Software NMI	5Eh
Reserved	5Fh
Options_0	60h
Options_1	61h
Shadow_SCI	62h
SwitchVoltageTime	63h
SwitchGHI_Time	64h
UsbPMControl	65h
MiscEnable66	66h
MiscEnable67	67h
MiscEnable68	68h
WatchDogTimerControl	69h
WatchDogTimerBase0	6Ch
WatchDogTimerBase1	6Dh
WatchDogTimerBase2	6Eh
WatchDogTimerBase3	6Fh
S_LdtStartTime	70h
EnhanceOption	71h
PopUpEndTime	73h
PwrFailShadow	74h
Tpreset1b	75h
SOS3ToS5Enable0	76h
SOS3ToS5Enable1	77h
SOS3ToS5Enable2	78h
SOS3ToS5Enable3	79h
NoStatusControl0	7Ah
NoStatusControl1	7Bh
MiscEnable7C	7Ch
DprSlpVrMinTime	7Dh
SMAF0	80h

Register Name	Offset Address
SMAF1	81h
SMAF2	82h
SMAF3	83h
WakePinCntl	84h
CF9Rst	85h
ThermThrotCntl	86h
LdtStpCmd	87h
LdtStartTime	88h
LdtStopDelay	89h
LdtAgpTimeCntl	8Ah
StutterTime	8Bh
StpClkDlyTime	8Ch
AbPmeCntl	8Dh
FakeAsr	8Eh
FakeAsrEn	8Fh
GEVENTOUT	90h
GEVENTEN	91h
GEVENTIN	92h
GPM98OUT	94h
GPM98EN	95h
GPM98IN	96h
EnhanceControl	9Ah
MsiSignature	9E:9Ch
AutoArbDisWaitTime	9Fh
Programlo4RangeLo	A0h
Programlo4RangeHi	A1h
Programlo5RangeLo	A2h
Programlo5RangeHi	A3h
Programlo6RangeLo	A4h
Programlo6RangeHi	A5h
Programlo7RangeLo	A6h
Programlo7RangeHi	A7h
PIO7654Enable	A8h
PIO7654Status	A9h
StrapStatus	B2:B0h
C2Count	B3h
C3Count	B4h
IMC_ASF_Fan_Temp_Enable	B6h
IMC_Volt_Enable	B7h
IMC_GroupA_Enable	B8h
IMC_GroupB_Enable	B9h
IMC_SMBus_Enable	BAh
IMC_ACPI_Enable	BBh
FC_Clk_Sel	BCh
SysClkCfg1	BD
SmiIndicator0	C0h
SmiIndicator1	C1h
SmiIndicator2	C2h
PostCode	C3h
ClkbufDrvStr_A	C4h
ClkbufDrvStr_B	C5h
ClkbufDrvStr_C	C6h
Spare	C7h
HT_TestControl	C8h
MultiK8Control	C9h
ClkPinControl	CAh
AltStrapControl	CBh
EpromStrapIndex	CCh

Register Name	Offset Address
EpromStrapData	CDh
Spare	CEh
PLLControl	CFh
SataClkControl	D0h
PIIParameter1	D1h
PIIParameter2	D2h
PIIParameter3	D3h
PIIParameter4	D4h
CpuRstCtrl	D5h
ASFClkCtrl	D6h
MiscD7	D7h

MiscControl - RW – 8 bits - [PM_Reg: 00h]			
Field Name	Bits	Default	Description
Reserved	0		
Timer1ExpEn	1	0b	Set to 1 to enable SMI# when PM_TIMER1 expires. When PM_TIMER1 (inactivity) expires, the SB will update bit 1 of MiscStatus and issue SMI#. This bit allows the software to disable/enable all inactivity timer reload enables at indexes 08,09, and 0A.
Timer2ExpEn	2	0b	Set to 1 to enable SMI# when PM_TIMER2 expires.
Reserved	3		
SmiReq	4	0b	Software initiated SMI#. When set, SB will update bit [4] of the MiscStatus and issue an SMI#.
Reserved	7:5		
MiscControl register			

MiscStatus - RW – 8 bits - [PM_Reg: 01h]			
Field Name	Bits	Default	Description
SmiEvent	0	0b	SB sets this bit to indicate an SMI# was issued due to events specified by index 02, 03, 04, 1C, or A8h
Timer1Exp	1	0b	SB sets this bit to indicate that PM_TIMER1 has expired.
Timer2Exp	2	0b	SB sets this bit to indicate that PM_TIMER2 has expired.
Reserved	3		
SmiReq	4	0b	SB sets this bit to indicate the software initiated SMI# was issued.
Reserved	6:5		
StatusRst	7	0b	Writing a 1 to this location will reset PM status registers 05h, 06h, and 07h, 1Dh, and A9h. This mechanism provides a quick way to reset all status.
MiscStatus register			

SmiWakeUpEventEnable1 - RW – 8 bits - [PM_Reg: 02h]			
Field Name	Bits	Default	Description
SmiWakeUpEventEnable1	7:0	00h	Enables SMI# on IRQ[15:8] activity.
SmiWakeUpEventEnable1 register.			

SmiWakeUpEventEnable2 - RW – 8 bits - [PM_Reg: 03h]			
Field Name	Bits	Default	Description
SmiWakeUpEventEnable2	7:0	00h	Enables SMI# on {IRQ[7:3], NMI, IRQ[1:0]} activity.
SmiWakeUpEventEnable2 register			

SmiWakeUpEventEnable3 - RW – 8 bits - [PM_Reg: 04h]			
Field Name	Bits	Default	Description
ExtEvent0	0	0b	Enables SMI# on external event input 0
ExtEvent1	1	0b	Enables SMI# on external event input 1
GAME_SMI_EN	2	0b	Enables SMI# on game port activity (201h)
FDD_SMI_EN	3	0b	Enables SMI# on floppy drive activity
HDD_SMI_EN	4	0b	Enables SMI# on IDE device activity (201h)
COM_SMI_EN	5	0b	Enables SMI# on serial ports activity (201h)
LPT_SMI_EN	6	0b	Enables SMI# on parallel port activity (201h)
SLP_SMI_EN	7	0b	Enables SMI# on sleep command
SmiWakeUpEventEnable3 register.			

SmiWakeUpEventStatus1 - RW – 8 bits - [PM_Reg: 05h]			
Field Name	Bits	Default	Description
SmiWakeUpEventStatus1	7:0	00h	Set to one to identify IRQ[15:8] activity as source of SMI#.
SmiWakeUpEventStatus1 register			

SmiWakeUpEventStatus2 - RW – 8 bits - [PM_Reg: 06h]			
Field Name	Bits	Default	Description
SmiWakeUpEventStatus2	7:0	00h	Set to one to identify IRQ[7:0] activity as source of SMI#.
SmiWakeUpEventStatus2 register			

SmiWakeUpEventStatus3 - RW – 8 bits - [PM_Reg: 07h]			
Field Name	Bits	Default	Description
ExtEvt0_SMI_Status	0	0b	Set to 1 to indicate ExtEvent0 as the source of SMI#. Write 1 to clear this bit.
ExtEvt1_SMI_Status	1	0b	Set to 1 to indicate ExtEvent1 as the source of SMI#. Write 1 to clear this bit.
GAME_SMI_Status	2	0b	Set to 1 to indicate game port activity as the source of SMI#. Write 1 to clear this bit.
FDD_SMI_Status	3	0b	Set to 1 to indicate floppy activity as the source of SMI#. Write 1 to clear this bit.
HDD_SMI_Status	4	0b	Set to 1 to indicate IDE activity as the source of SMI#. Write 1 to clear this bit.
COM_SMI_Status	5	0b	Set to 1 to indicate serial port activity as the source of SMI#. Write 1 to clear this bit.
LPT_SMI_Status	6	0b	Set to 1 to indicate parallel port activity as the source of SMI#. Write 1 to clear this bit.
SLP_SMI_Status	7	0b	Set to 1 to indicate sleep command as the source of SMI#. Write 1 to clear this bit.
SmiWakeUpEventStatus3 register			

InactiveTmrEventEnable1 - RW – 8 bits - PM_Reg: 08h]			
Field Name	Bits	Default	Description
InactiveTmrEventEnable1	7:0	00h	Enables Timer 1 reload on IRQ[15:8] activity.
InactiveTmrEventEnable1 register			

InactiveTmrEventEnable2 - RW – 8 bits - [PM_Reg: 09h]			
Field Name	Bits	Default	Description
InactiveTmrEventEnable2	7:0	00h	Enables Timer 1 reload on {IRQ[7:3], NMI, IRQ[1:0]} activity.
InactiveTmrEventEnable2 register			

InactiveTmrEventEnable3 - RW – 8 bits - [PM_Reg: 0Ah]			
Field Name	Bits	Default	Description
ExtEvt0_Timer1Enable	0	0b	Enables Timer1 reload on ExtEvent0 inactivity
ExtEvt1_Timer1Enable	1	0b	Enables Timer1 reload on ExtEvent1 inactivity
GamePort_Timer1Enable	2	0b	Enables Timer1 reload on Gameport inactivity
Floppy_Timer1Enable	3	0b	Enables Timer1 reload on Floppy port inactivity
IDE_Timer1Enable	4	0b	Enables Timer1 reload on IDE port inactivity
COM_Timer1Enable	5	0b	Enables Timer1 reload on COM port inactivity
Parallel_Timer1Enable	6	0b	Enables Timer1 reload on Parallel port inactivity
Reserved	7		
InactiveTmrEventEnable3 register			

PmTmr1InitValue - RW – 8 bits - [PM_Reg: 0Bh]			
Field Name	Bits	Default	Description
PmTmr1InitValue	5:0	000000b	6 bit-timer. Initial/reload value for 6 bit decremting counter. Count range from 1 minute to 64 minutes with 4 second accuracy.
Reserved	7:6		
PmTmr1InitValue register			

PmTmr1CurValue - R – 8 bits - [PM_Reg: 0Ch]			
Field Name	Bits	Default	Description
PmTmr1CurValue	5:0	-	Current value of decremting counter
Reserved	7:6		
PmTmr1CurValue register			

ExtEventCntrl - RW – 8 bits - [PM_Reg: 0Dh]			
Field Name	Bits	Default	Description
ExtEvent0State	0	-	Logical value of EXTEVENT0. [Read-only]
ExtEvent1State	1	-	Logical value of EXTEVENT1. [Read-only]
ExtEvent0RF	2	0b	Set to one to configure EXTEVENT0 as rising edge sensitive. 0 as falling edge sensitive
ExtEvent1RF	3	0b	Set to one to configure EXTEVENT1 as rising edge sensitive. 0 as falling edge sensitive
Reserved	7:4		
ExtEventCntrl register			

AcpiControl - RW – 8 bits - [PM_Reg: 0Eh]			
Field Name	Bits	Default	Description
AcpiSmiEn	0	0b	Set to 1 to enable SMI# generation when ACPI driver writes one to GBL_RLS (bit [2] of AcpiPm1CntBlk:00h). When an SMI# is issued, the SB updates bit [0] of the AcpiStatus register.
BIOS_RLS	1	0b	Writing 1 to this bit will cause GblStatus to be set. This bit is always read back as 0.
SmiCmdEn	2	0b	Set to 1 to enable SMI# generation when ACPI driver writes to the SmiCmd port. When set to 1, SB will update bit 2 of MiscStatus and issue an SMI# on write to SmiCmd port.
AcpiDecodeEnable	3	0b	Set to 1 to enable SB to decode the ACPI I/O address space. When set, SB uses the contents of the PM registers at index 20-2B to decode ACPI I/O address.
VRT_SMI_En	4	0b	Set to 1 to enable SB to generate SMI upon (RTC) VRT low.
Reserved	5		
RtcClkPUB	6	0b	This bit controls the integrated pull-up for RTCCLK 0: Enable 1: Disable

AcpiControl - RW – 8 bits - [PM_Reg: 0Eh]			
Field Name	Bits	Default	Description
Reserved	7	0b	
AcpiControl register			

AcpiStatus- R – 8 bits - PM_Reg: 0Fh]			
Field Name	Bits	Default	Description
AcpiSmiStatus	0	-	Set to 1 by SB to indicate SMI# was due to write to Acpi power management register.
SerrSmiStatus	1	-	SMI due to SERR#
SmiCmdStatus	2	-	Set to one by SB to indicate SMI# was due to write to AcpiSmiCmd port.
SmSmiStatus	3	-	SmBus SMI# status
UsbSmiStatus	4	-	USB SMI# status
SerSmiStatus	5	-	Serial SMI# status
RtcClkBad	6	-	0: Rtc clock running 1: Bad Rtc clock. RTC battery may not be present
NbThermStatus	7	-	NB thermal event status
AcpiStatus register			

AcpiEn - RW – 8 bits - [PM_Reg: 10h]			
Field Name	Bits	Default	Description
EOSEnle	0	0b	Set 1 by software and clear by hardware. This bit needs to be set in order to generate SMI#/SCI
RTC_En_En	1	0b	RTC_EN enable bit. When this bit is set, RTC_EN (AcpiPmEvtBlk, index x02, bit [10]) is visible; otherwise, it is always 0
Reserved	2		
TMR_En_En	3	0b	TMR_EN enable bit. When this bit is set, TM_EN (AcpiPmEvtBlk, index x02, bit [0]) is visible; otherwise, it is always 0
LEVENT_EN_EN	4	0b	LEVENT_EN enable bit. When this bit is set, LEVENT_EN (AcpiGpe0Blk, index x04, bit [8]) is visible; otherwise, it is always 0
GBL_EN_EN	5	0b	GBL_EN enable bit. When this bit set, GBL_EN (AcpiPmEvtBlk, index x02, bit [5]) is visible; otherwise, it is always 0
PciExpWakeDisEn	6	0b	PciExpWakeDis enable bit. When this bit is set to 1, PciExpWakeDis (AcpiPmEvtBlk, index x02, bit [14]) is visible (can be read/written).
GpioToGEventSel	7	0b	This bit is applicable to ASIC Revision A12 and newer. 0: ACPI_EVENT[30] register is routed to use GPIO2 as input 1: ACPI_EVENT[30] register is routed to use GPIO66 as input
AcpiEn register			

MiscEnable11- RW – 8 bits - [PM_Reg: 11h]			
Field Name	Bits	Default	Description
S1AgpStpEn	0	0b	AgpStp eable in S1 state 1: Enable 0: Disable
Reserved	1		
PwrGoodOut	2	0b	Output data for PwrGood pin
PwrGoodEnB	3	1b	Output enable for PwrGood pin (active low)
Reserved	7:4		

MiscEnable11- RW – 8 bits - [PM_Reg: 11h]			
Field Name	Bits	Default	Description
MiscEnable11 register			
PwrGoodOut and PwrGoodEnB are meant to be controlled by the integrated micro-controller (IMC). With IMC enabled, it will write to these bits directly to control PwrGood			

PmTmr2InitValue - RW – 8 bits - [PM_Reg: 12h]			
Field Name	Bits	Default	Description
PmTmr2InitValue	7:0	00h	PmTmr2 load value
PmTmr2InitValue register			

PmTmr2CurValue - R – 8 bits - [PM_Reg: 13h]			
Field Name	Bits	Default	Description
PmTmr2CurValue	7:0	--	PmTmr2 current value
PmTmr2CurValue register			

ProgramIo0RangeLo - RW – 8 bits - [PM_Reg: 14h]			
Field Name	Bits	Default	Description
ProgramIo0Mask	3:0	0h	These four bits are used to mask the least 4 bits of the 16 bit I/O. If bit [3] is set, then bit [3] of the I/O address is not compared. If it is not set, then bit [3] of the monitored address is 0. The same applies for the other three bits [2:0]. For example, if x15=80h, x14[7:4]=Ah, and x14[3:0]=3h, then the monitored range is 80A4h : 80A0h (bit 0 and 1 are masked)
ProgramIo0RangeLo	7:4	0h	I/O range base address. These bits define the least significant byte of the 16 bit I/O range base address that is programmed to trigger SMI# when the address is accessed. Bit 7 corresponds to Addr[7] and bit 4 to Addr[4].
ProgramIo0RangeLo register			

ProgramIo0RangeHi - RW – 8 bits - [PM_Reg: 15h]			
Field Name	Bits	Default	Description
ProgramIo0RangeHi	7:0	00h	I/O range base address. These bits define the most significant byte of the 16 bit I/O range base address. Bit 7 corresponds to Addr[15] and bit 0 to Addr[8].
ProgramIo0RangeHi register			

ProgramIo1RangeLo - RW – 8 bits - [PM_Reg: 16h]			
Field Name	Bits	Default	Description
ProgramIo1Mask	3:0	0h	These four bits are used to mask the least 4 bits of the 16 bit I/O. If bit [3] is set, then bit [3] of the I/O address is not compared. If it is not set, then bit [3] of the monitored address is 0. The same applies to the other three bits [2:0]. For example, if x15=80h, x14[7:4]=Ah, and x14[3:0]=3h, then the monitored range is 80A4h : 80A0h (bit 0 and 1 are masked)
ProgramIo1RangeLo	7:4	0h	I/O range base address. These bits define the least significant byte of the 16 bit I/O range base address that is programmed to trigger SMI# when the address is accessed. Bit 7 corresponds to Addr[7] and bit 4 to Addr[4].
ProgramIo1RangeLo register			

ProgramIo1RangeHi - RW – 8 bits - [PM_Reg: 17h]			
Field Name	Bits	Default	Description
ProgramIo1RangeHi	7:0	00h	I/O range base address. These bits define the most significant byte of the 16 bit I/O range base address. Bit 7 corresponds to Addr[15] and bit 0 to Addr[8].
ProgramIo1RangeHi register			

ProgramIo2RangeLo - RW – 8 bits - [PM_Reg: 18h]			
Field Name	Bits	Default	Description
ProgramIo2Mask	3:0	0h	These four bits are used to mask the least 4 bits of the 16 bit I/O. If bit [3] is set, then bit [3] of the I/O address is not compared. If it is not set, then bit [3] of the monitored address is 0. The same applies for the other three bits. For example, if x15=80h, x14[7:4]=Ah, and x14[3:0]=3h, then the monitored range is 80A4h : 80A0h (bit 0 and 1 are masked)
ProgramIo2RangeLo	7:4	0h	I/O range base address. These bits define the least significant byte of the 16 bit I/O range base address that is programmed to trigger SMI# when the address is accessed. Bit 7 corresponds to Addr[7] and bit 4 to Addr[4].
ProgramIo2RangeLo register			

ProgramIo2RangeHi - RW – 8 bits - [PM_Reg: 19h]			
Field Name	Bits	Default	Description
ProgramIo2RangeHi	7:0	00h	I/O range base address. These bits define the most significant byte of the 16 bit I/O range base address. Bit 7 corresponds to Addr[15] and bit 0 to Addr[8].
ProgramIo2RangeHi register			

ProgramIo3RangeLo - RW – 8 bits - [PM_Reg: 1Ah]			
Field Name	Bits	Default	Description
ProgramIo3Mask	3:0	0h	These four bits are used to mask the least 4 bits of the 16 bit I/O. If bit [3] is set, then bit [3] of the I/O address is not compared. If it is not set, then bit [3] of the monitored address is 0. The same applies to the other three bits [2:0]. For example, if x15=80h, x14[7:4]=Ah, and x14[3:0]=3h, then the monitored range is 80A4h : 80A0h (bit 0 and 1 are masked)
ProgramIo3RangeLo	7:4	0h	I/O range base address. These bits define the least significant byte of the 16 bit I/O range base address that is programmed to trigger SMI# when the address is accessed. Bit 7 corresponds to Addr[7] and bit 4 to Addr[4].
ProgramIo3RangeLo register			

ProgramIo3RangeHi - RW – 8 bits - [PM_Reg: 1Bh]			
Field Name	Bits	Default	Description
ProgramIo3RangeHi	7:0	00h	I/O range base address. These bits define the most significant byte of the 16 bit I/O range base address. Bit 7 corresponds to Addr[15] and bit 0 to Addr[8].
ProgramIo3RangeHi register			

ProgramIoEnable - RW – 8 bits - [PM_Reg: 1Ch]			
Field Name	Bits	Default	Description
AD_LIB_MonitorEn	0	0b	Enables AD_LIB monitoring (IO 388:389) to trigger SMI#, 1: On 0: Off

ProgramIoEnable - RW – 8 bits - [PM_Reg: 1Ch]			
Field Name	Bits	Default	Description
MIDI_MonitorEn	1	0b	Enables MIDI (IO 300:301, 310:311, 320:321, 330:331) monitoring to trigger SMI# 1: On 0: Off
AudioMSSMonitorEn	2	0b	Enables Audio/MSS (IO 220:233, 240:253, 260:273, 280:293, 530:537, 604:607, 608:60B, E80:E87, F40:F47) monitoring to trigger SMI# 1: On 0: Off
MouseKbMonitorEn	3	0b	Enables Mouse/Keyboard monitoring (IO 60, 64) to trigger SMI# 1: On 0: Off
ProgramIo3Enable	4	0b	Enables IO monitoring for ProgramIO3 (defined by index 1A, 1B) 1: On 0: Off
ProgramIo2Enable	5	0b	Enables IO monitoring for ProgramIO2 (defined by index 18, 19) 1: On 0: Off
ProgramIo1Enable	6	0b	Enables IO monitoring for ProgramIO1 (defined by index 16, 17) 1: On 0: Off
ProgramIo0Enable	7	0b	Enables IO monitoring for ProgramIo0 (defined by index 14, 15) 1: On 0: Off
ProgramIoEnable register			

IOMonitorStatus - RW – 8 bits - [PM_Reg: 1Dh]			
Field Name	Bits	Default	Description
AD_LIB_MonitorStatus	0	-	AD_LIB status bit; write 1'b1 to clear the status
MIDI_MonitorStatus	1	-	MIDI status bit; write 1'b1 to clear the status bit
AudioMSSMonitorStatus	2	-	Audio/MSS status bit; write 1'b1 to clear the status bit
MouseKbMonitorStatus	3	-	Mouse/keyboard status bit; write 1'b1 to clear the status bit
ProgramIo3Status	4	-	Programmable IO 3 status bit; write 1'b1 to clear the status bit
ProgramIo2Status	5	-	Programmable IO 2 status bit; write 1'b1 to clear the status bit
ProgramIo1Status	6	-	Programmable IO 1 status bit; write 1'b1 to clear the status bit
ProgramIo0Status	7	-	Programmable IO 0 status bit; write 1'b1 to clear the status bit
IOMonitorStatus register			

InactiveTmrEventEnable4 - RW – 8 bits - [PM_Reg: 1Eh]			
Field Name	Bits	Default	Description
AD_LIB_Timer1Enable	0	0b	Enables Timer1 reload on AD_LIB IO 388:389) inactivity
MIDI_Timer1Enable	1	0b	Enables Timer1 reload on MIDI (IO 300:301, 310:311, 320:321, 330:331) inactivity
Audio_Timer1Enable	2	0b	Enables Timer1 reload on Audio (IO 220:233, 240:253, 260:273, 280:293, 530:537, 604:607, 608:60B, E80:E87, F40:F47) inactivity
Keyboard_Time1Enable	3	0b	Enables Timer1 reload on Keyboard/Mouse port (IO 60/64) inactivity

InactiveTmrEventEnable4 - RW – 8 bits - [PM_Reg: 1Eh]			
Field Name	Bits	Default	Description
PIO3_Timer1Enable	4	0b	Enables Timer1 reload on PIO3 port inactivity
PIO2_Timer1Enable	5	0b	Enables Timer1 reload on PIO2 port inactivity
PIO1_Timer1Enable	6	0b	Enables Timer1 reload on PIO1 port inactivity
PIO0_Timer1Enable	7	0b	Enables Timer1 reload on PIO0 port inactivity
InactiveTmrEventEnable4 register			

AcpiPm1EvtBlkLo - RW – 8 bits - [PM_Reg: 20h]			
Field Name	Bits	Default	Description
Reserved	1:0		
AcpiPm1EvtBlkLo	7:2	00h	These bits define the least significant byte of the 16 bit I/O range base address of the ACPI power management Event Block. Bit 2 corresponds to Addr[2] and bit 7 corresponds to Addr[7].
AcpiPm1EvtBlkLo register			

AcpiPm1EvtBlkHi - RW – 8 bits - [PM_Reg: 21h]			
Field Name	Bits	Default	Description
AcpiPm1EvtBlkHi	7:0	00h	These bits define the most significant byte of the 16 bit I/O range base address. Bit 0 corresponds to Addr[8] and bit 7 corresponds to Addr[15].
AcpiPm1EvtBlkHi register			

AcpiPm1CntBlkLo - RW – 8 bits - [PM_Reg: 22h]			
Field Name	Bits	Default	Description
Reserved	0		
AcpiPm1CntBlkLo	7:1	00h	These bits define the least significant byte of the 16 bit I/O base address of the ACPI power management Control block. Bit 1 corresponds to Addr[1] and bit 7 corresponds to Addr[7].
AcpiPm1CntBlkLo register			

AcpiPm1CntBlkHi - RW – 8 bits - [PM_Reg: 23h]			
Field Name	Bits	Default	Description
AcpiPm1CntBlkHi	7:0	00h	These bits define the most significant byte of the 16 bit I/O base address. Bit 0 corresponds to Addr[8] and bit 7 corresponds to Addr[15].
AcpiPm1CntBlkHi register			

AcpiPmTmrBlkLo - RW – 8 bits - [PM_Reg: 24h]			
Field Name	Bits	Default	Description
Reserved	0		
AcpiPmTmrBlkLo	7:1	00h	These bits define the least significant byte of the 16 bit I/O base address of the ACPI power management Timer block. Bit 1 corresponds to Addr[1] and bit 7 corresponds to Addr[7].
AcpiPmTmrBlkLo register			

AcpiPmTmrBlkHi - RW – 8 bits - [PM_Reg: 25h]			
Field Name	Bits	Default	Description
AcpiPmTmrBlkHi	7:0	00h	These bits define the most significant byte of the 16 bit I/O base address. Bit 0 corresponds to Addr[8] and bit 7 corresponds to Addr[15].
AcpiPmTmrBlkHi register			

CpuControlLo - RW – 8 bits - [PM_Reg: 26h]			
Field Name	Bits	Default	Description
Reserved	2:0		
CpuControlLo	7:3	00h	These bits define the least significant byte of the 16 bit I/O base address of the ACPI power management CPU Control block. Bit 3 corresponds to Addr[3] and bit 7 corresponds to Addr[7]. Addr[2:0] are ignored because this register block is 6 byte long.
CpuControlLo register			

CpuControlHi - RW – 8 bits - [PM_Reg: 27h]			
Field Name	Bits	Default	Description
CpuControlHi	7:0	00h	These bits define the most significant byte of the 16 bit I/O base address. Bit 0 corresponds to Addr[8] and bit 7 corresponds to Addr[15].
CpuControlHi register			

AcpiGpe0BlkLo - RW – 8 bits - [PM_Reg: 28h]			
Field Name	Bits	Default	Description
Reserved	1:0		
AcpiGpe0BlkLo	7:2	00h	These bits define the least significant byte of the 16 bit I/O base address of the ACPI power management General Purpose Event block. Bit 2 corresponds to Addr[2] and bit 7 corresponds to Addr[7]. Addr[1:0] are ignored because this register block is 4 byte long.
AcpiGpe0BlkLo register			

AcpiGpe0BlkHi - RW – 8 bits - [PM_Reg: 29h]			
Field Name	Bits	Default	Description
AcpiGpe0BlkHi	7:0	00h	These bits define the most significant byte of the 16 bit I/O base address. Bit 0 corresponds to Addr[8] and bit 7 corresponds to Addr[15].
AcpiGpe0BlkHi register			

AcpiSmiCmdLo - RW – 8 bits - [PM_Reg: 2Ah]			
Field Name	Bits	Default	Description
AcpiSmiCmdLo	7:0	00h	These bits define the least significant byte of the 16 bit I/O base address of the ACPI SMI Command block. Bit 0 corresponds to Addr[0] and bit 7 corresponds to Addr[7]. The address is required to be WORD-aligned (Addr[0]=0)
AcpiSmiCmdLo register			

AcpiSmiCmdHi - RW – 8 bits - [PM_Reg: 2Bh]			
Field Name	Bits	Default	Description
AcpiSmiCmdHi	7:0	00h	These bits define the most significant byte of the 16 bit I/O base address. Bit 0 corresponds to Addr[8] and bit 7 corresponds to Addr[15].
AcpiSmiCmdHi register			

AcpiPm2CntBlkLo - RW – 8 bits - [PM_Reg: 2Ch]			
Field Name	Bits	Default	Description
AcpiPm2CntBlkLo	7:0	00h	These bits define the least significant byte of the 16 bit I/O base address of the ACPI power management additional control block. Bit 0 corresponds to Addr[0] and bit 7 corresponds to Addr[7].

AcpiPm2CntBlkLo - RW – 8 bits - [PM_Reg: 2Ch]			
Field Name	Bits	Default	Description
AcpiPm2CntBlkLo register			

AcpiPm2CntBlkHi - RW – 8 bits - [PM_Reg: 2Dh]			
Field Name	Bits	Default	Description
AcpiPm2CntBlkHi	7:0	00h	These bits define the most significant byte of the 16 bit I/O base address. Bit 0 corresponds to Addr[8] and bit 7 corresponds to Addr[15].
AcpiPm2CntBlkHi register			

GEvtConfig0 – RW – 8 bits - [PM_Reg: 30h]			
Field Name	Bits	Default	Description
GEvtConfig0	7:0	00h	GEVENT Configuration. These 8 bits are used for configuring general purpose events 0-3. Two bits for each event pin. Bit[1:0] for GEVENT[0], bit[3:2] for GEVENT[1] and so on 00: ACPI Event (trigger SCIOUT or SMI# depending on SCI_EN bit) 01: GEVENT to generate SMI# 10: GEVENT to generate SMI# followed by SCI 11: GEVENT to generate IRQ13
GEvtConfig0 register			

GEvtConfig1 – RW – 8 bits - [PM_Reg: 31h]			
Field Name	Bits	Default	Description
GEvtConfig1	7:0	00h	GEVENT Configuration. These 8 bits are used for configuring General Purpose Events 4-7. Two bits for each event pin. Bit[1:0] for GEVENT[4], bit[3:2] for GEVENT[5] and so on 00: ACPI Event (trigger SCIOUT or SMI# depending on SCI_EN bit) 01: GEVENT to generate SMI# 10: GEVENT to generate SMI# followed by SCI 11: GEVENT to generate IRQ13
GEvtConfig1 register			

GPMConfig0 – RW – 8 bits - [PM_Reg: 32h]			
Field Name	Bits	Default	Description
ExtEvent0Config	1:0	00b	These two bits configure ExtEvent0 00: ACPI Event (trigger SCIOUT or SMI# depending on SCI_EN bit) 01: ExtEvent0 to generate SMI# 10: ExtEvent0 to generate SMI# followed by SCI 11: ExtEvent0 to generate IRQ13
ExtEvent1Config	3:2	00b	These two bits configure ExtEvent1 00: ACPI Event (trigger SCIOUT or SMI# depending on SCI_EN bit) 01: ExtEvent1 to generate SMI# 10: ExtEvent1 to generate SMI# followed by SCI 11: ExtEvent1 to generate IRQ13

GPMConfig0 – RW – 8 bits - [PM_Reg: 32h]			
Field Name	Bits	Default	Description
PcIePmeConfig	5:4	00b	These two bits configure PCIePme 00: ACPI Event (trigger SCIOUT or SMI# depending on SCI_EN bit) 01: PCIePme to generate SMI# 10: PCIePme to generate SMI# followed by SCI 11: PCIePme to generate IRQ13
Gpm0Config	7:6	00b	These two bits configure GPM0 00: ACPI Event (trigger SCIOUT or SMI# depending on SCI_EN bit) 01: GPM0 to generate SMI# 10: GPM0 to generate SMI# followed by SCI 11: GPM0 to generate IRQ13
GPMConfig0 register			

GPMConfig1- RW – 8 bits - [PM_Reg: 33h]			
Field Name	Bits	Default	Description
Gpm1Config	1:0	00b	These two bits configure GPM1 00: ACPI Event (trigger SCIOUT or SMI# depending on SCI_EN bit) 01: Gpm1 to generate SMI# 10: Gpm1 to generate SMI# followed by SCI 11: Gpm1 to generate IRQ13
Gpm2Config	3:2	00b	These two bits configure GPM2 00: ACPI Event (trigger SCIOUT or SMI# depending on SCI_EN bit) 01: Gpm2 to generate SMI# 10: Gpm2 to generate SMI# followed by SCI 11: Gpm2 to generate IRQ13
Gpm3Config	5:4	00b	These two bits configure GPM3 00: ACPI Event (trigger SCIOUT or SMI# depending on SCI_EN bit) 01: GPM3 to generate SMI# 10: GPM3 to generate SMI# followed by SCI 11: GPM3 to generate IRQ13
Gpm8Config	7:6	00b	These two bits configure GPM8 00: ACPI Event (trigger SCIOUT or SMI# depending on SCI_EN bit) 01: GPM8 to generate SMI# 10: GPM8 to generate SMI# followed by SCI 11: GPM8 to generate IRQ13
GPMConfig1 register			

GPMConfig2- RW – 8 bits - [PM_Reg: 34h]			
Field Name	Bits	Default	Description
Gpio0Config	1:0	00b	These two bits configure Gpio0 or WAKE# 00: ACPI Event (trigger SCIOUT or SMI# depending on SCI_EN bit) 01: Gpio0 to generate SMI# 10: Gpio0 to generate SMI# followed by SCI 11: Gpio0 to generate IRQ13
Gpm4Config	3:2	00b	These two bits configure GPM4 00: ACPI Event (trigger SCIOUT or SMI# depending on SCI_EN bit) 01: Gpm4 to generate SMI# 10: Gpm4 to generate SMI# followed by SCI 11: Gpm4 to generate IRQ13

GPMConfig2- RW – 8 bits - [PM_Reg: 34h]			
Field Name	Bits	Default	Description
Gpm5Config	5:4	00b	These two bits configure GPM5 00: ACPI Event (trigger SCIOUT or SMI# depending on SCI_EN bit) 01: Gpm5 to generate SMI# 10: Gpm5 to generate SMI# followed by SCI 11: Gpm5 to generate IRQ13
AzPmeConfig	7:6	00b	These two bits configure AzPme 00: ACPI Event (trigger SCIOUT or SMI# depending on SCI_EN bit) 01: AzPme to generate SMI# 10: AzPme to generate SMI# followed by SCI 11: AzPme to generate IRQ13
GPMConfig2 register			

GPMConfig3 – RW – 8 bits - [PM_Reg: 35h]			
Field Name	Bits	Default	Description
Gpm6Config	1:0	00b	These two bits configure GPM6 00: ACPI Event (trigger SCIOUT or SMI# depending on SCI_EN bit) 01: Gpm6 to generate SMI# 10: Gpm6 to generate SMI# followed by SCI 11: Gpm6 to generate IRQ13
Gpm7Config	3:2	00b	These two bits configure GPM7 00: ACPI Event (trigger SCIOUT or SMI# depending on SCI_EN bit) 01: Gpm7 to generate SMI# 10: Gpm7 to generate SMI# followed by SCI 11: Gpm7 to generate IRQ13
Gpio2Config	5:4	00b	These two bits configure Gpio2 00: ACPI Event (trigger SCIOUT or SMI# depending on SCI_EN bit) 01: Gpio2 to generate SMI# 10: Gpio2 to generate SMI# followed by SCI 11: Gpio2 to generate IRQ13
SataSciConfig	7:6	00b	These two bits configure SataSci 00: ACPI Event (trigger SCIOUT or SMI# depending on SCI_EN bit) 01: SataSci to generate SMI# 10: SataSci to generate SMI# followed by SCI 11: SataSci to generate IRQ13
GPMConfig3 register			

GEvtLevelConfig - RW – 8 bits - [PM_Reg: 36h]			
Field Name	Bits	Default	Description
GEvtLevelConfig	7:0	00h	GEVENT input level configuration 1: Rising edge trigger 0: Falling edge trigger
GEvtLevelConfig register			

GPMLevelConfig0 - RW – 8 bits - [PM_Reg: 37h]			
Field Name	Bits	Default	Description
ExtEvent0LevelConfig	0	0b	ExtEvent0 input level configuration 1: Rising edge trigger 0: Falling edge trigger

GPMLevelConfig0 - RW – 8 bits - [PM_Reg: 37h]			
Field Name	Bits	Default	Description
ExtEvent1LevelConfig	1	0b	ExtEvent1 input level configuration 1: Rising edge trigger 0: Falling edge trigger
PClePmeLevelConfig	2	0b	PClePme input level configuration 1: Rising edge trigger 0: Falling edge trigger
Gpm0LevelConfig	3	0b	GPM0 input level configuration 1: Rising edge trigger 0: Falling edge trigger
Gpm1LevelConfig	4	0b	GPM1 input level configuration 1: Rising edge trigger 0: Falling edge trigger
Gpm2LevelConfig	5	0b	GPM2 input level configuration 1: Rising edge trigger 0: Falling edge trigger
Gpm3LevelConfig	6	0b	GPM3 input level configuration 1: Rising edge trigger 0: Falling edge trigger
Gpm8LevelConfig	7	0b	GPM8 input level configuration 1: Rising edge trigger 0: Falling edge trigger
GPMLevelConfig0 register			

GPMLevelConfig1 - RW – 8 bits - [PM_Reg: 38h]			
Field Name	Bits	Default	Description
Gpio0LevelConfig	0	0b	Gpio[0] or WAKE# input level configuration 1: Rising edge trigger 0: Falling edge trigger
Gpm4LevelConfig	1	0b	GPM4 input level configuration 1: Rising edge trigger 0: Falling edge trigger
Gpm5LevelConfig	2	0b	GPM5 input level configuration 1: Rising edge trigger 0: Falling edge trigger
AzPmeLevelConfig	3	0b	AzPme input level configuration 1: Rising edge trigger 0: Falling edge trigger
Gpm6LevelConfig	4	0b	GPM6 input level configuration 1: Rising edge trigger 0: Falling edge trigger
Gpm7LevelConfig	5	0b	GPM7 input level configuration 1: Rising edge trigger 0: Falling edge trigger
Gpio2LevelConfig	6	0b	Gpio[2] input level configuration 1: Rising edge trigger 0: Falling edge trigger
SataSciLevelConfig	7	0b	SataSci input level configuration 1: Rising edge trigger 0: Falling edge trigger
GPMLevelConfig1 register			

GEvtStatus - RW – 8 bits - [PM_Reg: 39h]			
Field Name	Bits	Default	Description
GEvtStatus	7:0	--	GEVENT status. Write 1 to clear each bit
GEvtStatus register			

PMESStatus0 - RW – 8 bits - [PM_Reg: 3Ah]			
Field Name	Bits	Default	Description
ExtEvent0Status	0	0b	EXTEVENT0 -> SMI# status; write 1 to clear
ExtEvent1Status	1	0b	EXTEVENT1 -> SMI# status; write 1 to clear
PClePmeStatus	2	0b	PClePme -> SMI# status; write 1 to clear
Gpm0Status	3	0b	GPM0 -> SMI# status; write 1 to clear
Gpm1Status	4	0b	GPM1 -> SMI# status; write 1 to clear
Gpm2Status	5	0b	GPM2 -> SMI# status; write 1 to clear
Gpm3Status	6	0b	GPM3 -> SMI# status; write 1 to clear
Gpm8Status	7	0b	GPM8 -> SMI# status; write 1 to clear
PMESStatus0 register			

PMESStatus1- RW – 8 bits - [PM_Reg: 3Bh]			
Field Name	Bits	Default	Description
Gpio0Status	0	0b	Gpio0 or WAKE# -> SMI# status; write 1 to clear
Gpm4Status	1	0b	GPM4 -> SMI# status; write 1 to clear
Gpm5Status	2	0b	GPM5 -> SMI# status; write 1 to clear
AzPmeStatus	3	0b	AzPme -> SMI# status; write 1 to clear
Gpm6Status	4	0b	GPM6 -> SMI# status; write 1 to clear
Gpm7Status	5	0b	GPM7 -> SMI# status; write 1 to clear
Gpio2Status	6	0b	Gpio2 -> SMI# status; write 1 to clear
SataSciStatus	7	0b	SataSci -> SMI# status; write 1 to clear
PMESStatus1 register			

OthersConfig- RW – 8 bits - [PM_Reg: 3Ch]			
Field Name	Bits	Default	Description
LegacySMIConfig	1:0	00b	These two bits configure legacy SMI# events 00: ACPI Event (trigger SCIOUT or SMI# depending on SCI_EN bit) 01: Legacy SMI EVENT to generate SMI# 10: Legacy SMI EVENT to generate SMI# followed by SCI 11: Legacy SMI EVENT to generate IRQ13
TALERTConfig	3:2	00b	These two bits configure TALERT pin 00: ACPI Event (trigger SCIOUT or SMI# depending on SCI_EN bit) 01: TALERT to generate SMI# 10: TALERT to generate SMI# followed by SCI 11: TALERT to generate IRQ13
USBConfig	5:4	00b	These two bits configure internal USB PME 00: ACPI Event (trigger SCIOUT or SMI# depending on SCI_EN bit) 01: UsbPme to generate SMI# 10: UsbPme to generate SMI# followed by SCI 11: UsbPme to generate IRQ13
IMC_Config	7:6	00b	These two bits configure internal IMC SCI/PME 00: ACPI Event (trigger SCIOUT or SMI# depending on SCI_EN bit) 01: IMC_SCI to generate SMI# 10: IMC_SCI to generate SMI# followed by SCI 11: IMC_SCI to generate IRQ13
OthersConfig register			

MorePmeConfig – RW – 8 bits - [PM_Reg: 3Dh]			
Field Name	Bits	Default	Description
OtherThermConfig	1:0	00b	These two bits configure OtherTherm 00: ACPI Event (trigger SCIOUT or SMI# depending on SCI_EN bit) 01: OtherTherm to generate SMI# 10: OtherTherm to generate SMI# followed by SCI 11: OtherTherm to generate IRQ13
Gpm9Config	3:2	00b	These two bits configure GPM[9] 00: ACPI Event (trigger SCIOUT or SMI# depending on SCI_EN bit) 01: GPM[9] to generate SMI# 10: GPM[9] to generate SMI# followed by SCI 11: GPM[9] to generate IRQ13
PCleHotPlugConfig	5:4	00b	These two bits configure PCleHotPlug 00: ACPI Event (trigger SCIOUT or SMI# depending on SCI_EN bit) 01: PCleHotPlug to generate SMI# 10: PCleHotPlug to generate SMI# followed by SCI 11: PCleHotPlug to generate IRQ13
Reserved	7:6		
MorePmeConfig register			

VRT_T1 - RW – 8 bits - [PM_Reg: 3Eh]			
Field Name	Bits	Default	Description
VRT_T1	7:0	01h	The RTC battery is sampled (to conserve power) periodically to checks its state of health. VRT_T1 and VRT_T2 make up the interval of the checking. When VRT_Enable is high, the battery is being sampled. When VRT_enable is low, the battery is not being sampled. This register defines the time of VRT enable being high for RTC battery monitor circuit, in milliseconds.
VRT_T1 register			

VRT_T2 - RW – 8 bits - [PM_Reg: 3Fh]			
Field Name	Bits	Default	Description
VRT_T2	7:0	FFh	This register defines the time of VRT enable being low for the RTC battery monitor circuit, in 4 ms increment.
VRT_T2 register			

AD_Pull_UpB - RW – 8 bits - [PM_Reg: 40h]			
Field Name	Bits	Default	Description
AD_Pull_UpB	7:0	00h	This register controls integrated pull-up for AD[31:24] respectively. 0: Enable 1: Disable
AD_Pull_UpB register: pull up resistor value is approximately 10K			

AD23 Pull_UpB - RW – 8 bits - [PM_Reg: 41h]			
Field Name	Bits	Default	Description
AD23_Pull_UpB	0	0b	This bit controls integrated pull-up for AD[23]. 0: Enable 1: Disable
PCI5Enable	1	0b	1: Enable PCICLK5/GPIO41 as PCICLK5 0: Configure PCICLK5/GPIO41 as GPIO function
SysRst2PllEn	2	0b	When set, SYS_RST# will reset PLL completely

AD23_Pull_UpB - RW – 8 bits - [PM_Reg: 41h]			
Field Name	Bits	Default	Description
SlpS3ToLdtPwrGdEn	3	0b	When set, assertion of SLP_S3# will cause LDT_PWRGD to deassert immediately (This applies to ASIC revision A12 or after)
Clk25_48_66DrvSth	4	0b	25M_48M_66M_OSC pin drive strength control 0: 4ma output drive strength 1: 8 ma output drive strength (This applies to ASIC revision A12 or later)
CLk14_25_48DrvSthB	5	0b	When USBCLK/14M_25M_48M_OSC pin is configured as clock output, this bit configures the drive strength. Please note the negative polarity 0: 8 ma output drive strength 1: 4 ma output drive strength (This applies to ASIC revision A12 or later)
LpcClk0DrvStr*	6	00b	A14: set to 1 to increase LPCCLK0 drive strength from 4 to 8ma
LpcClk1DrvStr*	7	0b	A14: set to 1 to increase LPCCLK1 drive strength from 4 to 8ma
AD23_Pull_UpB register: pull up resistor value is approximately 10K. Bits marked by "*" are only available for ASIC revision A14 and above. On ASIC A11/12, they cannot be written, and reading them will yield undefined values.			

MiscPmControl - RW – 8 bits - [PM_Reg: 42h]			
Field Name	Bits	Default	Description
CPU_IO_PullDownDrvStrength	0	0b	When set, the integrated pull-down drive strength of all CPU I/Os are increased by 50%
DisableBootFailCpuRst	1	0b	This bit can be used to disable the boot fail timer to prevent an LDTPG assertion when the bootfail timer expires.
C2ToC3Enable	2	0b	If set to 1, SB will treat C2 as C3
RstCpuPGE	3	0b	If set to 1, SB toggles LDTPG on every reset
Reserved	4	1b	
BmStsRdMask	5	0b	If set to 1, read from BM_STS will be blocked and always return 0
RtcClkDrive	6	1b	0: HIGHDRIVE tied low for RtcClkOut pad 1: HIGHDRIVE tied high for RtcClkOut pad
SSEnable	7	0b	Set this bit to enables the spread spectrum PLL
MiscPmControl register			

StpClkHoldTime - RW – 8 bits - [PM_Reg: 43h]			
Field Name	Bits	Default	Description
StpClkHoldTime	7:0	FFh	Obsolete function. Not used anymore
StpClkHoldTime register			

ResetStatus0 - R – 8 bits - [PM_Reg: 44h]			
Field Name	Bits	Default	Description
UserResetSts	0	0b	1 means the previous reset was caused by user pressing the reset button
PMIO55RstSts	1	0b	1 means the previous reset was caused by PMIO55
Cf9RstSts	2	0b	1 means the previous reset was caused by CF9 (or PMIO85)
ASFRstSts	3	0b	1 means the previous reset was caused by remote reset command
reserved	4		
SleepRstSts	5	0b	1 means the previous reset was caused by sleep state or shutdown (thermal or shutdown pin)
KbRstSts	6	0b	1 means the previous reset was caused by keyboard reset

ResetStatus0 - R – 8 bits - [PM_Reg: 44h]			
Field Name	Bits	Default	Description
LT_RstSts	7	0b	1 means the previous reset was caused by link reset
ResetStatus0 register			

ResetStatus1 - R – 8 bits - [PM_Reg: 45h]			
Field Name	Bits	Default	Description
FailBootRstSts	0	0b	1 means the previous reset was caused by AMD fail boot timer
WatchDogRstSts	1	0b	1 means the previous reset was caused by the standard watchdog timer
SyncFloodRstSts	2	0b	1 means the previous reset was caused by the Sync Flood message
ImcWatchDogRstSts	3	0b	1 means the previous reset was caused by the watchdog timer in the embeded controller
reserved	7:4	0h	
ResetStatus1 register: this register is used by BIOS to determine what causes the previous system reset			

Note: PMIO_4F:46 are available for use

PM_Enable - RW – 8 bits - [PM_Reg: 50h]			
Field Name	Bits	Default	Description
Reserved	7:0	0b	Obsolete function. Do not use
PM_Enable register			

TPRESET1 - RW – 8 bits - [PM_Reg: 51h]			
Field Name	Bits	Default	Description
Reserved	7:0	05h	Obsolete function. Do not use
Reserved	7:6		
TPRESET1 register			

TPRESET2 - RW – 8 bits - [PM_Reg: 52h]			
Field Name	Bits	Default	Description
TPRESET2	5:0	08h	Timing parameter used for S* -> S0 state transitions. This register determines the CPU_STP# deassertion delay in 8µs increment with 8us uncertainty.
Reserved	7:6		
TPRESET2 register			

TESTENABLE - RW – 8 bits - [PM_Reg: 53h]			
Field Name	Bits	Default	Description
Reserved	0	0b	Obsolete function. Do not use
Reserved	2:1		
SMI_Disable	3	0b	When set, SMI# generation will be disabled. SMI status can still be set except SMI will not be generated and passed to CPU
Sel_wakeclk	4	0b	Test feature only: set 1 to use OSC as the wake up clock; otherwise, use RTC CLK as the wake up clock. SW should not change this value under normal operating condition
Reserved	5	0b	
Precise14MhzEnable	6	0b	The SP5100 does not have a 14Mhz input; instead, it uses ½ of the 25Mhz input. When this bit is set, the SP5100 will use the internal PLL to generate the 14.31818Mhz.
IntruderAlertDis	7	0b	Set to 1 to disable INTRUDER_ALERT# input

TESTENABLE - RW – 8 bits - [PM_Reg: 53h]			
Field Name	Bits	Default	Description
TESTENABLE register			

ShutDownStatus - RW – 8 bits - [PM_Reg: 54h]			
Field Name	Bits	Default	Description
TFATAL_STS	0	0b	When read, this bit is marked 1 if there was a Thermtrip# pin event. Write 1 to clear the TFATAL status bit
PWRBTTN_STS	1	0b	When read, this bit is marked 1 if the previous shut down was caused by PwrButton. Write 1 to clear the Power Button Override status bit
SHUTDOWN_STS	2	0b	When read, this bit is marked 1 if there was a shut down. Write 1 to clear the GPIO5/SHUTDOWN/SMARTVOLT2 status bit
INTRUDER_ALERT_STS	3	0b	When read, this bit is marked 1 if there is an INTRUDER_ALERT# event. Write 1 to clear the IntruderAlert status bit. Starting from A14, SW needs to write 0 to this bit after clearing the status (writing 1); otherwise, the status bit will stay cleared.
TEMPHRMTRIP_STS	4	0b	When read, this bit is marked 1 if there was a Thermtrip# event from the internal temperature sensor. Write 1 to clear the TempThrmTrip status bit
SHUTDOWNFAN0_STS	5	0b	When read, this bit is marked 1 if there was a FAN1 event. Write 1 to clear the SHUTDOWNFAN0 bit
SHUTDOWNFAN1_STS	6	0b	When read, this bit is marked 1 if there was a FAN2 event. Write 1 to clear the SHUTDOWNFAN1 bit
SHUTDOWNFAN2_STS	7	0b	When read, this bit is marked 1 if there was a FAN3 event. Write 1 to clear the SHUTDOWNFAN2 bit
ShutDownStatus register			

SoftPciRst – RW – 8 bits – [PM_Reg:55h]			
Field Name	Bits	Default	Description
SoftPciRstEn	0	1b	This bit enables both the soft PCIRST and the THRMTRIP function.
Gpm8CIRWakeSel	1	0b	select either GPM8 or CIR wake event to ACPI.GEVENT[23] 0: Use GPM8 1: Use CIR wake
UserResetEnable	2	1b	When set, GPM7 becomes user reset pin.
PcieNative	3	0b	Set to 1 to enable PCIe® native PME mode support (sending PCIePme and Ack message)
Pcie_Wak_Mask	4	0b	Set to 1 to mask out wake event from PCIe devices
Pcie_WAK_Sci	5	0b	Set to 1 to cause acpi not generate Sci interrupt if ACPI is enabled and PCIE_WAK_STS bit in PM1a_STS is set.
SoftPciRst	6	0b	Setting bit [6] will cause a PCIRST.
ImcWatchDogRstEn	7	0b	This bit enables the reset from the watchdog timer in the enbeded controller.
SoftPciRst register			

Reserved – 8 bits - [PM_Reg: 56h]			
Field Name	Bits	Default	Description
Reserved	7:0	00h	
Reserved			

Reserved – 8 bits - [PM_Reg: 57h]			
Field Name	Bits	Default	Description
Reserved	7:0	05h	

Reserved – 8 bits - [PM_Reg: 57h]			
Field Name	Bits	Default	Description
Reserved			

Reserved – 8 bits - [PM_Reg: 58h]			
Field Name	Bits	Default	Description
Reserved	7:0	0Ch	
Reserved			

MiscOption - RW – 8 bits - [PM_Reg: 59h]			
Field Name	Bits	Default	Description
FlashControllerEn	0	0b	Setting the bit to “1” will enable the flash controller as a stand-alone device
FlashControllerMode	1	0b	Setting the bit to “1” enables flash controller and disables ide controller Setting the bit to “0” disables flash controller and enables ide controller
SataClkSelect	2	0b	0: External clk 1: Shared with PCIe® 100MHz clock
AzEnable	3	1b	1: Enable HD AUDIO module 0: Disable HD AUDIO module
AzSnoopEnable	4	0b	When set, HD AUDIO data transfer will not cause the BM_STS bit to be set and to wake up the CPU from C3 state. This is used when previous version of SB did not have C state pop-up/down function. With the new pop-up/down function in the SP5100, this function is not necessary and should not be enabled if the C-state pop-up/down is enabled.
Gpio5ShutdownEn	5	0b	Shutdown system if seeing a negative edge on Gpio5
WriteBackEnable	6	0b	AZ write back enable
IntruderAlertSmiEn	7	0b	IntruderAlert SMI# enable
MiscOption register			

SmiSciSts0 - RW – 8 bits - [PM_Reg: 5Ah]			
Field Name	Bits	Default	Description
GeventStatus	7:0	00h	These bits indicate the SMI# status of the eight general purpose event signals if they are configured to generate SMI# followed by SCI
SmiSciSts0 register			

SmiSciSts1 - RW – 8 bits - [PM_Reg: 5Bh]			
Field Name	Bits	Default	Description
LEventStatus	0	0b	This bit indicates the SMI# status of the legacy power management logic if it is configured to generate SMI# followed by SCI
TwarnStatus	1	0b	This bit indicates the SMI# status of the Temperature Caution input if it is configured to generate SMI# followed by SCI
Reserved	2	0b	
USBStatus	3	0b	This bit indicates the SMI# status of the PME# from the internal USB controller if it is configured to generate SMI# followed by SCI
Reserved	4	0b	
OtherThermStatus	5	0b	This bit indicates the SMI# status of OtherTherm from NB, fan, etc. if it is configured to generate SMI# followed by SCI
GPM9Status	6	0b	This bit indicates the SMI# status of GPM[9] if it is configured to generate SMI# followed by SCI
PCIeHotPlugStatus	7	0b	This bit indicates the SMI# status of PCIeHotPlug if it is configured to generate SMI# followed by SCI

SmiSciSts1 - RW – 8 bits - [PM_Reg: 5Bh]			
Field Name	Bits	Default	Description
SmiSciSts1 register			

SmiSciSts2 - RW – 8 bits - [PM_Reg: 5Ch]			
Field Name	Bits	Default	Description
ExtEvent0Status	0	0b	This bit indicates the SMI# status of ExtEvent0 to SCI/Wakeup if it is configured to generate SMI# followed by SCI
ExtEvent1Status	1	0b	This bit indicates the SMI# status of ExtEvent1 to SCI/Wakeup if it is configured to generate SMI# followed by SCI
PClePmeStatus	2	0b	This bit indicates the SMI# status of the PME# from PCIe® if it is configured to generate SMI# followed by SCI
GPM0Status	3	0b	This bit indicates the SMI# status of GPM[0] to SCI/Wakeup if it is configured to generate SMI# followed by SCI
GPM1Status	4	0b	This bit indicates the SMI# status of GPM[1] to SCI/Wakeup if it is configured to generate SMI# followed by SCI
GPM2Status	5	0b	This bit indicates the SMI# status of GPM[2] to SCI/Wakeup if it is configured to generate SMI# followed by SCI
GPM3Status	6	0b	This bit indicates the SMI# status of GPM[3] to SCI/Wakeup if it is configured to generate SMI# followed by SCI
GPM8Status	7	0b	This bit indicates the SMI# status of GPM[8] to SCI/Wakeup if it is configured to generate SMI# followed by SCI
SmiSciSts2 register			

SmiSciSts3 - RW – 8 bits - [PM_Reg: 5Dh]			
Field Name	Bits	Default	Description
Gpio0Status	0	0b	This bit indicates the SMI# status of GPIO0 (or WAKE#/GEVENT8 pin if PM IO Reg 84h bit1 =1) to SCI/wakeup if it is configured to generate SMI# followed by SCI
GPM4Status	1	0b	This bit indicates the SMI# status of GPM[4] to SCI/Wakeup if it is configured to generate SMI# followed by SCI
GPM5Status	2	0b	This bit indicates the SMI# status of GPM[5] to SCI/Wakeup
AzaliaStatus	3	0b	This bit indicates the SMI# status from the internal HD Audio controller if it is configured to generate SMI# followed by SCI
GPM6Status	4	0b	This bit indicates the SMI# status of GPM[6] to SCI/Wakeup if it is configured to generate SMI# followed by SCI
GPM7Status	5	0b	This bit indicates the SMI# status of GPM[7] to SCI/Wakeup if it is configured to generate SMI# followed by SCI
Gpio2Status	6	0b	This bit indicates the SMI# status of GPIO2 to SCI/wakeup if it is configured to generate SMI# followed by SCI
SataSciStatus	7	0b	This bit indicates the SMI# status of SataSci to SCI/wakeup
SmiSciSts3 register			

Software NMI - RW – 8 bits - [PM_Reg: 5Eh]			
Field Name	Bits	Default	Description
Reserved	4:0	00000b	Do not write 1 to any of these bits (debugging purpose only)
SwNmi	5	0	Write 1 to generate to software NMI. This is to allow the BIOS to artificially generate a NMI.
Reserved	7:6	00b	

Reserved- RW – 8 bits - [PM_Reg: 5Fh]			
Field Name	Bits	Default	Description
Reserved	7:0	00h	
(Usage TBD)			

Options_0 - RW – 8 bits - [PM_Reg: 60h]			
Field Name	Bits	Default	Description
TAlertFanEn	0	0b	Set this bit to put all fans to full speed if TALERT# is asserted
ProcHotFanEn	1	0b	Set this bit to put all fans to full speed if PROCHOT# is asserted
Fan1En	2	0b	Setting this bit will configure GPIO48 pin to be FAN1 output
Fan2En	3	0b	Setting this bit will configure GPIO49 pin to be FAN2 output
Fan3En	4	0b	Setting this bit will configure GPIO39 pin to be FAN3 output
SpkrEn	5	0b	Setting this bit will configure GPIO2 to be speaker output
Fan0En	6	0b	Setting this bit will configure GPIO3 to be FAN0 output
Reserved	7		
Options_0 register			

Options_1 - RW – 8 bits - [PM_Reg: 61h]			
Field Name	Bits	Default	Description
Reserved	0		Reserved for BIOS use
IsAmd	1	0b	Set to enable NB/SB handshake during IOAPIC interrupt for AMD K6 or K7 class; Clear for other CPU.
PCI_Active_enable	2	0b	BIOS should set this bit in order to monitor BM_STS pin from NB (the pin is called BMREQ# on SB) and bus mastering from the SB itself.
UseCpuRst	3	1b	If this bit is not set, then system reset will cause INIT# instead of CPURST#.
ProcHotStsEn	4	0b	Set to enable PROCHOT# to generate TwarnStatus and thermal throttle
Reserved	5		
UsbPmeEnable	6	0b	USB PME enable
Reserved	7		
Options_1 register			

Shadow_SCI- R – 8 bits - [PM_Reg: 62h]			
Field Name	Bits	Default	Description
Shadow_SCI	0	0b	SCI output
Reserved	7:1		
Shadow_SCI register			

Reserved - RW – 8 bits - [PM_Reg: 63h]			
Field Name	Bits	Default	Description
Rsaved	7:0	05h	

Reserved - RW – 8 bits - [PM_Reg: 64h]			
Field Name	Bits	Default	Description
Rsaved	7:0	052	

UsbPMControl- RW – 8 bits - [PM_Reg: 65h]			
Field Name	Bits	Default	Description
UsbPhyS5PwrDwnEnable	0	0b	Set to 1 to enable S4/S5 USB Phy power down support and to disable S4 USB wakeup support. The bit has to be clear to 0 (default) to support S4 USB wakeup.
Reserved	1	0b	
UsbResumeEnable	2	1b	Set to 1 to enable S3 wakeup on USB device resume
Reserved	3	0b	
UsbResetByPciRstEnable	4	1b	Set to 1 to reset USB on the software (such as IO-64 or IO-CF9 cycles) generated PCIRST#.
UsbS5ResetEnable	5	1b	Set to 1 to enable USB reset on S4/S5 resume detection
USB resume from connect (For SP5100 A14 and above)	6	0b	Set to '1' to allow USB device wake from disconnect / connect
SpecialFunc	7	0b	If set to 1, S* -> S0 state transitions will use 1ms clock tick for timing sequence; otherwise, 8µs clock will be used. For K8 system, this bit must be cleared to use 8µs clock.
UsbPMControl register			

MiscEnable66 - RW – 8 bits - [PM_Reg: 66h]			
Field Name	Bits	Default	Description
UsbBusyBreakEn	0	0b	Setting this bit to 1 will cause C3 wakeup when USB OHCI or EHCI DMA is active.
UsbOhciCstateMask	1	0b	Setting this bit to 1 will prevent system from entering C state when USB OHCI DMA is active.
Reserved	4:2		
K8KbRstEn	5	0b	KB_RST# control for K8 system 0: Generate INIT# 1: Generate PCIRST#
UsbBusyBmStsEn	6	0b	Setting this bit to 1 will cause C3 pop-up when USB OHCI or EHCI DMA is active.
UsbOhciBmStsRdEn	7	0b	Setting this bit to 1 will keep BM_STS read as 1 regardless of BmStsRdMask when USB OHCI DMA is active.
MiscEnable66 register			

MiscEnable67 – RW – 8 bits – [PM_Reg:67h]			
Field Name	Bits	Default	Description
Reserved	1:0	00b	
CC_En	2	0b	C State enable. This bit must be set in order to exercise the C state
Reserved	3		
BypassPwrGoodEn	4	0b	If asserted, the southbridge will not wait for deassertion of PWRGOOD to monitor for wakeup event
TempPolarity	6:5	00b	Temperature polarity control for THRMTRIP and TALERT respectively. 0: active low; 1; active high
DlySlpEn	7	0b	Set to 1 to delay recognition of STPGNT# until there is no pending read in AB
MiscEnable67 register			

MiscEnable68 – RW – 8 bits – [PM_Reg:68h]			
Field Name	Bits	Default	Description
Reserved	0	0b	

MiscEnable68 – RW – 8 bits – [PM_Reg:68h]			
Field Name	Bits	Default	Description
MaskCState	1	0b	If this bit is set, any pending breakevent will prevent the SB to enter C state. This is an obsolete function and so the software should leave it as 0
MaskApicEn	2	1b	If set, the APIC interrupt will be deferred until the first ACPI access when the system resumes from S state. For K8 CPU additionally A20M# IGNNE# INTR NMI INIT# will be deferred the same way, but SMI# will not be deferred.
THRMTRIP_Enable	3	1b	When set, GEVENT2 becomes THRMTRIP function. When THRMTRIP pin is low and PM 55h, bit 0 is set, hardware will switch the system to S5 automatically.
MaskRtcClkOut	4	0b	If set, RtcClkOut will stop toggling.
LLB_Enable	5	0b	If set, LLB function is enabled, system won't wakeup from ACPI S state until LLB# is de-asserted.
AcpiThrotPeriod	7:6	00b	Selects the software clock throttling period 00: 15µs 01: 30µs 10: 244µs 11: Reserved
MiscEnable68 register			

WatchDogTimerControl – RW – 8 bits – [PM_Reg:69h]			
Field Name	Bits	Default	Description
WatchDogTimerDisable	0	1b	When set, watchdog timer will be disabled
WatchDogTimerResolution	2:1		00: 32KHz resolution 01: 10ms 10: 100ms 11: 1 second
Reserved	7:3		
WatchDogTimerControl register			

WatchDogTimerBase0 – RW – 8 bits – [PM_Reg:6Ch]			
Field Name	Bits	Default	Description
Reserved	2:0		
WatchDogTimerBase0	7:3	0000_0b	WatchDogTimer Base address [7:3]
WatchDogTimerBase0 register			

WatchDogTimerBase1 – RW – 8 bits – [PM_Reg:6Dh]			
Field Name	Bits	Default	Description
WatchDogTimerBase1	7:0	00h	WatchDogTimer Base address [15:8]
WatchDogTimerBase1 register			

WatchDogTimerBase2 – RW – 8 bits – [PM_Reg:6Eh]			
Field Name	Bits	Default	Description
WatchDogTimerBase2	7:0	00h	WatchDogTimer Base address [23:16]
WatchDogTimerBase2 register			

WatchDogTimerBase3 – RW – 8 bits – [PM_Reg:6Fh]			
Field Name	Bits	Default	Description
WatchDogTimerBase3	7:0	00h	WatchDogTimer Base address [31:24]
WatchDogTimerBase3 register			

S_LdtStartTime – RW – 8 bits – [PM_Reg:70h]			
Field Name	Bits	Default	Description
S_LdtStartTime	7:0	00h	This register defines the delay between SUS_STAT# assertion and LDTSTP# assertion when the K8 system enters ACPI S states, in 1us increment, with 1us uncertainty.
S_LdtStartTime register			

EnhanceOption – RW – 8 bits – [PM_Reg:71h]			
Field Name	Bits	Default	Description
Reserved	2:0	000b	
Fid_protect_en	3		
VidFidExtraDelayEn	4	0b	If enabled, extra duration of LDTSTP# assertion as specified by VidFidExtraDelaySelect will be added to the VID/FID change sequence. 1: Enable 0: Disable
VidFidExtraDelaySelect	7:5	000b	3'b000: 0ns 3'b001: 140ns 3'b010: 210ns 3'b011: 280ns 3'b110: 350ns 3'b111: 420ns 3'b100: 490ns 3'b101: 560ns
EnhanceOption register			

Reserved – RW – 8 bits – [PM_Reg:72h]			
Field Name	Bits	Default	Description
Reserved	7:0	0Bh	

PopUpEndTime – RW – 8 bits – [PM_Reg:73h]			
Field Name	Bits	Default	Description
PopUpEndTime	7:0	80h	During C3 pop-up, the SB monitors DMA traffic. If there has been no traffic for PopUpEndTime, SB will bring system back to C3. Count is in number of 14Mhz clock
PopUpEndTime register			

PwrFailShadow – RW – 8 bits – [PM_Reg:74h]			
Field Name	Bits	Default	Description
PwrFailShadow	3:0	0h	Writing to these four bits will set the value onto bits [7:4]. Software should always set bit 2 = 1 on every access to this register to reflect the 'On' power state.
PwrFailOption (Read-only)	5:4	00b	These two bits will determine how the system should resume after a power failure. 00: Always off: always power off after power resumes. 01: Always on: always power on after power resumes 10: Always off: always power off after power resumes 11: Use previous: resume to same setting when power fails.
PowerState (Read-only)	6	0b	Power state indicator 1: On 0: Off
ForcePwrOn (Read-only)	7	0b	If set and RTC AIE =1, will force power on after power resumes regardless of bits[5:4] setting; if cleared and RTC AIE = 1, will wakeup when RTC alarm fires after a power failure/resume.

PwrFailShadow – RW – 8 bits – [PM_Reg:74h]			
Field Name	Bits	Default	Description
PwrFailShadow register			

Tpreset1b – RW – 6 bits – [PM_Reg:75h]			
Field Name	Bits	Default	Description
Tpreset1b	5:0	05h	Timing parameter used for S* -> S0 state transition. This determines the delay between CPU_STP# de-assertion and SUS_STAT# de-assertion, in 8us increment with 8us uncertainty.
DelayRomRstEn	6	1b	1: 30ms ahead of deassertion of PciRst# 0: ROM_RST functions the same as PciRst#
DelayLanRstEn	7	1b	1: 20ms ahead of deassertion of PciRst# 0: Lan_RST functions the same as PciRst#
Tpreset1b register			

S0S3ToS5Enable0 – RW – 8 bits – [PM_Reg:76h]			
Field Name	Bits	Default	Description
S0S3ToS5Enable0	7:0	FFh	This register determines which wakeup signals can be passed onto the S5 region. For S4/S5 wake up, this bit must be set in before the corresponding pin can be used Bit [7:0]: GEVENT#[7:0] 1: Enable 0: Disable
S0S3ToS5Enable0 register			

S0S3ToS5Enable1 – RW – 8 bits – [PM_Reg:77h]			
Field Name	Bits	Default	Description
S0S3ToS5Enable1	7:0	FFh	This register determines which wakeup signals can be passed onto the S5 region. For S4/S5 wake up, this bit must be set in before the corresponding pin can be used Bit [7:0]: GPM#[7:0] 1: Enable 0: Disable
S0S3ToS5Enable1 register			

S0S3ToS5Enable2 – RW – 8 bits – [PM_Reg:78h]			
Field Name	Bits	Default	Description
S0S3ToS5Enable2	7:0	FFh	This register determines which wakeup signals can be passed onto the S5 region. For S4/S5 wake up, this bit must be set in before the corresponding pin can be used Bit [0]: Spare Bit [1]: Internal USB Bit [2]: EXTEVENT#[0] Bit [3]: EXTEVENT#[1] Bit [4]: External IRQ8 Bit [5]: GPIO[0] Bit [6]: GPIO[1] Bit [7]: GPIO[2] 1: Enable 0: Disable
S0S3ToS5Enable2 register			

S0S3ToS5Enable3 – RW – 8 bits – [PM_Reg:79h]			
Field Name	Bits	Default	Description
S0S3ToS5Enable3	7:0	FFh	This register determines which wakeup signals can be passed onto the S5 region. For S4/S5 wake up, this bit must be set in before the corresponding pin can be used Bit [0]: GPIO[3] Bit [1]: Spare Bit [2]: SATA_SCI Bit [3]: Spare Bit [4]: Spare Bit [5]: Spare Bit [6]: S5ResetOverride Bit [7]: Enable bit to pass PCI config gevent1_en* bits 1: Enable 0: Disable
S0S3ToS5Enable3 register			

NoStatusControl0 – RW – 8 bits – [PM_Reg:7Ah]			
Field Name	Bits	Default	Description
NoStatusControl0	7:0	00h	For GEVENT#[7:0] configured as PME# (wakeup function), additional setting of these bits will still allow GEVENT# pins to wakeup the system but they will not set the status bit in the ACPI GEVENT status register. Bits [7:0] control GEVENT#[7:0] respectively 0: Allow status 1: Not-allow status
NoStatusControl0 register			

NoStatusControl1 – RW – 8 bits – [PM_Reg:7Bh]			
Field Name	Bits	Default	Description
NoStatusControl1	7:0	00h	This register should be set the same as 7A
NoStatusControl1 register			

MiscEnable7C – RW – 8 bits – [PM_Reg:7Ch]			
Field Name	Bits	Default	Description
BreakEnable	0	1b	Set to 1 to allow wakeup from C3 without asserting LDTSTP# in K8 system
BusReqHoldEn	1	1b	Set to 1 to capture bus mastering request for pop-up during LDTSTP# minimum assertion time
BlinkControl	3:2	00b	Blinking interval select 00: Always off 01: 1sec on, 3sec off, repeating 10: 2sec on, 2sec off, repeating 11: Always on
AltCenturyEnable	4	0b	Set to 1 to enable RTC AltCentury register
SusStatOption	5	0b	SUS_STAT# timing option enable. When set, SUS_STAT# deassertion will always be ~2 RTCCLK delay from ARST#.
WaitStpGntEnB	6	0b	0: Wait for STPGNT# in ACPI S state; 1: No wait
Reserved	7	0b	
MiscEnable7C register			

Reserved– RW – 8 bits – [PM_Reg:7Dh]			
Field Name	Bits	Default	Description
Reserved	7:0	02h	

Note: PMIO_7E:7F are used to access additional configuration registers that are powered by RTC battery (registers that are not covered in CMOS or CMOS_RAM). See section [2.4.6](#)

RtcExtIndex – RW – 8 bits – [PM_Reg:7Eh]			
Field Name	Bits	Default	Description
RtcExtIndex	7:0	00h	
RtcExtIndex register			

RtcExtData – RW – 8 bits – [PM_Reg:7Fh]			
Field Name	Bits	Default	Description
RtcExtData	7:0		
RtcExtData register			

SMAF0 – RW – 8 bits – [PM_Reg:80h]			
Field Name	Bits	Default	Description
S45SMAF	2:0	110b	System management action field for S4/5 STPCLK message
Reserved	3		
C2SMAF	6:4	0h	System management action field for C2 STPCLK message
Reserved	7		
SMAF0 register			

SMAF1 – RW – 8 bits – [PM_Reg:81h]			
Field Name	Bits	Default	Description
C3SMAF	2:0	001b	System management action field for C3 STPCLK message
Reserved	3		
VFSMAF	6:4	010b	System management action field for VFID STPCLK message
Reserved	7		
SMAF1 register			

SMAF2 – RW – 8 bits – [PM_Reg:82h]			
Field Name	Bits	Default	Description
S1SMAF	2:0	011b	System management action field for S1 STPCLK message
Reserved	3		
S3SMAF	6:4	100b	System management action field for S3 STPCLK message
Reserved	7		
SMAF2 register			

SMAF3 – RW – 8 bits – [PM_Reg:83h]			
Field Name	Bits	Default	Description
NSSMAF	2:0	101b	System management action field for Normal Throttling STPCLK message
Reserved	3		
TTSMAF	6:4	101b	System management action field for Thermal Throttling STPCLK message
Reserved	7		
SMAF3 register			

WakePinCntl – RW – 8 bits – [PM_Reg:84h]			
Field Name	Bits	Default	Description
WakePinEnable	0	1b	Set to 1 to enable wakeup from WAKE#/GEVENT#[8] pin
WakePinAsGEvent	1	0b	Set to 1 to use WAKE#/GEVENT#[8] pin as GEvent, replacing GPIO0
WakeOut	2	0b	Output data for wake pin

WakePinCntl – RW – 8 bits – [PM_Reg:84h]			
Field Name	Bits	Default	Description
WakeOutEnB	3	1b	Output enable for wake pin (active low)
WakePinStatus	4	0b	Input status for wake pin
GenImcClkEn	5	0b	Enables IMC clock in S3/4/5 state even if IMC is not enabled
Reserved	7:6	00b	
WakePinCntl register			

CF9Rst – RW – 8 bits – [PM_Reg:85h]			
Field Name	Bits	Default	Description
Reserved	0		
SysRst	1	0b	0: Send INIT HT message 1: Reset as specified by bit3
RstCmd	2	0b	Write with 1 to generate reset as specified by bit[3,1] Write only, always read as 0
FullRst	3	0b	0: Assert reset signals only 1: Place system in S5 state for 3 to 5 seconds
Reserved	7:4		
CF9Rst register			

ThermThrotCntl – RW – 8 bits – [PM_Reg:86h]			
Field Name	Bits	Default	Description
Therm2SecDelay	0	0b	Enables 2 second delay for thermal clock throttle
ThrottleControl	4:1	0000b	Bit[4] Enable thermal clock throttle Bits[3:1] Throttle interval for STPCLK# de-assertion 000b: 50% 001b: 12.5% 010b: 25% 011b: 37.5% 100b: 50% 101b: 62.5% 110b: 75% 111b: 87.5%
ThermThrotPeriod	5	0b	Selects the thermal clock throttle period 0: 30us 1: 244us
Reserved	7:6		
ThermThrotCntl register			

LdtStpCmd – RW – 8 bits – [PM_Reg:87h]			
Field Name	Bits	Default	Description
Reserved	0	0b	
Reserved	7:1		
LdtStpCmd register			

LdtStartTime – RW – 8 bits – [PM_Reg:88h]			
Field Name	Bits	Default	Description
LdtStartTime	7:0	06h	LDTSTP# assertion delay in 1us increment
LdtStartTime register			

LdtStopDelayTime – RW – 8 bits – [PM_Reg:89h]			
Field Name	Bits	Default	Description
LdtStopDelayTime	7:0	00h	This value sets the minimum time delay from the STPCLK assertion to the first assertion of LDTSTOP# in microseconds. Note that this delay only applies to the first assertion of a C3 or FID_VID sequence. Subsequent timing control on LDTSTOP# (in stutter mode) are set by PM_Reg:88h and 8Bh
LdtStopDelayTime register			

LdtAgpTimeCntl – RW – 8 bits – [PM_Reg:8Ah]			
Field Name	Bits	Default	Description
LdtEndTime	1:0	00b	LDTSTP# de-assertion delay select 00: 0µs 01: 1µs 10: 32µs 11: 64µs
LdtEndTime	3:2	00b	AGP_STP# de-assertion delay select 00: 0µs 01: 1µs 10: 32µs 11: 64µs
VfidTime	6:4	001b	VID/FID LDTSTP# duration select 000: 1µs 001: 2µs 010: 4µs 011: 8µs 100: 16µs 101: 32µs 110: 64µs 111: 128µs
StutterMode	7	1b	Set to 1 to enable stutter mode
LdtAgpTimeCntl register			

StutterTime – RW – 8 bits – [PM_Reg:8Bh]			
Field Name	Bits	Default	Description
StutterTime	7:0	01h	LDTSTP# duration in 1us increment
StutterTime register			

StpClkDlyTime – RW – 8 bits – [PM_Reg:8Ch]			
Field Name	Bits	Default	Description
StpClkDlyTime	7:0	00h	STPCLK# deassertion delay in number of OSC clocks for S1 resume in K8 system.
StpClkDlyTime register			

MiscEnable8D – RW – 8 bits – [PM_Reg:8Dh]			
Field Name	Bits	Default	Description
PmeMsgEn	0	0b	Set to 1 to enable PmeTurnOff/PmeMsgAck handshake
SlpS2En	1	0b	Set to 1 to enable GPM9 as SLP_S2 output
AzRstEn	2	0b	Set to 1 to enable GPM8 as AZ_RST# output
DprStpEn	3	0b	Set to 1 to enable DPRSTP# output
Usb11Ron	4	1b	Set to 1 to enable the integrated pull-down resistors on the USB 11 pads
LongSLPS3	5	0b	Set to 1 to extend SLP_S3# assertion to 1sec minimum
EffMaskEn ThrotStpGntEnB	7:6		

MiscEnable8D – RW – 8 bits – [PM_Reg:8Dh]			
Field Name	Bits	Default	Description
AbPmeCntl register			

FakeAsr– RW – 8 bits – [PM_Reg:8Eh]			
Field Name	Bits	Default	Description
FakeAsr	7:0	00h	Fake alternate status
FakeAsr register			

FakeAsrEn– RW – 8 bits – [PM_Reg:8Fh]			
Field Name	Bits	Default	Description
FakeAsrEn	0	0b	FakeAsr enable. If set, SB will return a fake status (defined in PMIO_8Eh) when IDE DMA is actively busy and software tries to read the status from the IDE device
UseBypassRom	1	0b	When this bit is set, it will override the ROM straps and use bits 3:2 of this register to determine which type of ROM to use. This is for BIOS debugging purpose or for if system desires to have multiple BIOS on board
BypassRomSel	3:2	00b	These two bits will override the two ROM strap pins. 00: LPC ROM 10: FWH ROM 11: SPI ROM 01: Reserved
BmReqPopUpEn	4	0b	When set (along with C state PopUp enabled), BmReq# input will not cause BM_STS to be set; instead, it will simply act just like AllowLdtStop and cause the C state machine to pop-up to C2. This bit is only valid under K8 CPU configuration.
MaskNbBmStsSet	5	1b	When set, BmStsSet message from NB will not cause wake up from C state.
MemRstDisable	6	0b	When set, the memory reset function at DDR_RST# pin will be disabled and can be used as GPM5#
DisableOtherIrq8	7	0b	When set, other source of interrupt 8 (serial IRQ, HPET) will not be routed to the SCI. Only RTC interrupt will be routed to the SCI
FakeAsrEn register			

GEVENTOUT – RW – 8 bits – [PM_Reg:90h]			
Field Name	Bits	Default	Description
GEVENTOUT	7:0	00h	GEVENT[7:0] output value
GEVENTOUT register			

GEVENTEN – RW – 8 bits – [PM_Reg:91h]			
Field Name	Bits	Default	Description
GEVENTEN	7:0	FFh	GEVENT[7:0] output enable 0: Enable 1: Tristate
GEVENTEN register			

GEVENTIN – RW – 8 bits – [PM_Reg:92h]			
Field Name	Bits	Default	Description
GEVENTIN	7:0	--	GEVENT[7:0] input status
GEVENTIN register			

GEVENTLock – RW – 8 bits – [PM_Reg:93h]			
Field Name	Bits	Default	Description
GEVENTLock	7:0	--	When the bit is set, the control of the corresponding GEVENT is locked by IMC. When locked, the corresponding pull-up/down (defined in PMIO2_F4:F3) is also locked. 1: Locked by IMC 0: Not locked by IMC
GEVENTLock register			

GPM98OUT – RW – 8 bits – [PM_Reg:94h]			
Field Name	Bits	Default	Description
GPM98OUT	1:0	00b	GPM[9:8] output value
GPM98EN	3:2	11b	GPM[9:8] output enable 0: Enable 1: Tristate
GPM98IN	5:4	--	GPM[9:8] input status
GPM98Lock	7:6	00b	These two bits are writeable by IMC only. When set, the corresponding pin is locked by IMC. When locked, the corresponding pull-up/down (defined in PMIO2_F5) is also locked
GPM98OUT register			

UsbSleepCtrl – RW – 8 bits – [PM_Reg:95h]			
Field Name	Bits	Default	Description
UsbSleepCtrl	2:0	000b	Control on USB advanced async sleep function, default standard async sleep. 000b: Standard 10us sleep, default 001b: Advanced sleep up to 1 uframe 010b: Advanced sleep up to 2 uframes 110b: Advanced sleep up to 6 uframes 111b: Reserved, HC behavior undefined
PciBridgeMloOverride	3	0b	When set, PCIBridge (Device 20h, function 4) memory and IO enable is always is true; even if the bits are set to 0
Reserved	7:4	0000b	
UsbSleepCtrl register			

EnhanceControl - RW - 8 bits - [PM_Reg: 9Ah]			
Field Name	Bits	Default	Description
Reserved	1:0	00b	
K8C3PopUpEn	2	1b	If this bit is set, SB can pop up from C3 to C2 in the case of bus mastering (DMA) instead of transitioning to C0. After DMA, it goes back to C3 with minimum delay of LdtStartTime.
AutoArbDisEn	3	0b	If this bit is set, SB will automatically set the ARB_DIS bit when entering C3.
auto_bm_rld	4	0b	If this bit is set, BM_STS will cause SB to pop-up or wakeup from C3 even if BM_RLD is not set.
auto_clr_bm_sts	5	0b	If this bit is set, BM_STS will be cleared when system enters C3.
FastReadEnable	6	0b	This bit is to make the read from ADC as fast as possible.
Reserved	7	1b	
EnhanceControl register			

MsiSignature - R - 24 bits - [PM_Reg: 9E:9Ch]			
Field Name	Bits	Default	Description
MsiSignature	19:0	00000h	This defines the MSI signature SB will monitor. This corresponds to address [39:20]. When SB sees transaction with this address, it will issue a break event to the C state machine if the CPU is in C2/3/4 state
HPET_Control	23:20	1101h	Control HPET internal datapath.
MsiSignature register			

AutoArbDisWaitTime - RW - 8 bits - [PM_Reg: 9Fh]			
Field Name	Bits	Default	Description
AutoArbDisWaitTime	3:0	0h	This defines the amount of time (in 2 μ s increment) that SB will hold ARB_DIS set after breaking from C3. This is to allow sometime for CPU to resume from C3 before allowing any bus mastering to the memory. This timer has an uncertainty of - 2 μ s. This applies to K8 C1e if AutoArbDisEn is set.
UseOscAsClk14*	4	0b	For ASIC A14: When set, internal 14MHz clock is coming directly form the OSC pin.
UsePll2ForClk14*	5	0b	For ASIC A14: When set, the internal 14MHz clock is derived from the PLL2 instead of PLL1. PLL2 clock is not spread.
Pll2UseOsc*	6	0b	For ASIC A14: when SB is in external clock mode, setting this bit will cause PLL2 to use the 25MHz OSC clock as source instead of the PCIe [®] 100MHz ref clock.
HWM_ResetOption	7	0h	0: HWM is reset by Rsmrst 1: HWM is reset by Pcirst
AutoArbDisWaitTime register. Bits marked by "*" are only available for ASIC revision A14. On ASIC A12, they cannot be written, and reading them will yield undefined values.			

ProgramIo4RangeLo - RW – 8 bits - [PM_Reg: A0h]			
Field Name	Bits	Default	Description
ProgramIo4Mask	3:0	0h	These four bits are used to mask the least 4 bits of the 16 bit I/O. If bit [3] is set, then bit [3] of the I/O address is not compared. If it is not set, then bit [3] of the monitored address is 0. The same applies for the other three bits [2:0]. For example, if x15=80h, x14[7:4]=Ah, and x14[3:0]=3h, then the monitored range is 80A4h : 80A0h (bit 0 and 1 are masked)
ProgramIo4RangeLo	7:4	0h	I/O range base address; these bits define the least significant byte of the 16 bit I/O range base address that is programmed to trigger SMI# when the address is accessed. Bit 7 corresponds to Addr[7] and bit 4 to Addr[4].
ProgramIo4RangeLo register			

ProgramIo4RangeHi - RW – 8 bits - [PM_Reg: A1h]			
Field Name	Bits	Default	Description
ProgramIo4RangeHi	7:0	00h	I/O range base address; these bits define the most significant byte of the 16 bit I/O range base address. Bit 7 corresponds to Addr[15] and bit 0 to Addr[8].
ProgramIo4RangeHi register			

Programlo5RangeLo - RW – 8 bits - [PM_Reg: A2h]			
Field Name	Bits	Default	Description
Programlo5Mask	3:0	0h	These four bits are used to mask the least 4 bits of the 16 bit I/O. If bit [3] is set, then bit [3] of the I/O address is not compared. If it is not set, then bit [3] of the monitored address is 0. The same applies for the other three bits [2:0]. For example, if x15=80h, x14[7:4]=Ah, and x14[3:0]=3h, then the monitored range is 80A4h : 80A0h (bit 0 and 1 are masked)
Programlo5RangeLo	7:4	0h	I/O range base address; these bits define the least significant byte of the 16 bit I/O range base address that is programmed to trigger SMI# when the address is accessed. Bit 7 corresponds to Addr[7] and bit 4 to Addr[4].
Programlo5RangeLo register			

Programlo5RangeHi - RW – 8 bits - [PM_Reg: A3h]			
Field Name	Bits	Default	Description
Programlo5RangeHi	7:0	00h	I/O range base address; these bits define the most significant byte of the 16 bit I/O range base address. Bit 7 corresponds to Addr[15] and bit 0 to Addr[8].
Programlo5RangeHi register			

Programlo6RangeLo - RW – 8 bits - [PM_Reg: A4h]			
Field Name	Bits	Default	Description
Programlo6Mask	3:0	0h	These four bits are used to mask the least 4 bits of the 16 bit I/O. If bit [3] is set, then bit [3] of the I/O address is not compared. If it is not set, then bit [3] of the monitored address is 0. The same applies for the other three bits [2:0]. For example, if x15=80h, x14[7:4]=Ah, and x14[3:0]=3h, then the monitored range is 80A4h : 80A0h (bit 0 and 1 are masked)
Programlo6RangeLo	7:4	0h	I/O range base address; these bits define the least significant byte of the 16 bit I/O range base address that is programmed to trigger SMI# when the address is accessed. Bit 7 corresponds to Addr[7] and bit 4 to Addr[4].
Programlo6RangeLo register			

Programlo6RangeHi - RW – 8 bits - [PM_Reg: A5h]			
Field Name	Bits	Default	Description
Programlo6RangeHi	7:0	00h	I/O range base address; these bits define the most significant byte of the 16 bit I/O range base address. Bit 7 corresponds to Addr[15] and bit 0 to Addr[8].
Programlo6RangeHi register			

ProgramIo7RangeLo - RW – 8 bits - [PM_Reg: A6h]			
Field Name	Bits	Default	Description
ProgramIo7Mask	3:0	0h	These four bits are used to mask the least 4 bits of the 16 bit I/O. If bit [3] is set, then bit [3] of the I/O address is not compared. If it is not set, then bit [3] of the monitored address is 0. The same applies for the other three bits [2:0]. For example, if x15=80h, x14[7:4]=Ah, and x14[3:0]=3h, then the monitored range is 80A4h : 80A0h (bit 0 and 1 are masked)
ProgramIo7RangeLo	7:4	0h	I/O range base address; these bits define the least significant byte of the 16 bit I/O range base address that is programmed to trigger SMI# when the address is accessed. Bit 7 corresponds to Addr[7] and bit 4 to Addr[4].
ProgramIo7RangeLo register			

ProgramIo7RangeHi - RW – 8 bits - [PM_Reg: A7h]			
Field Name	Bits	Default	Description
ProgramIo7RangeHi	7:0	00h	I/O range base address; these bits define the most significant byte of the 16 bit I/O range base address. Bit 7 corresponds to Addr[15] and bit 0 to Addr[8].
ProgramIo7RangeHi register			

PIO7654Enable - RW – 8 bits - [PM_Reg: A8h]			
Field Name	Bits	Default	Description
ProgramIo4Enable	0	0b	Enables IO monitoring for ProgramIO4 (defined by index A0, A1). 1: On 0: Off
ProgramIo5Enable	1	0b	Enables IO monitoring for ProgramIO5 (defined by index A2, A3). 1: On 0: Off
ProgramIo6Enable	2	0b	Enables IO monitoring for ProgramIO6 (defined by index A4, A5). 1: On 0: Off
ProgramIo7Enable	3	0b	Enables IO monitoring for ProgramIO7 (defined by index A6, A7). 1: On 0: Off
ProgramPciConfig0Enable	4	0b	Enables IO monitoring to generate SMI for ProgramPciConfig0 (defined by index AB:AA). 1: On 0: Off
ProgramPciConfig1Enable	5	0b	Enables IO monitoring to generate SMI for ProgramPciConfig1 (defined by index AB:AA). 1: On 0: Off
ProgramPciMem0Enable	6	0b	Enables IO monitoring to generate SMI for ProgramPciMem0 (defined by index AF:AC). 1: On 0: Off
ProgramPciMem1Enable	7	0b	Enables IO monitoring to generate SMI for ProgramPciMem1 (defined by index AF:AC). 1: On 0: Off
PIO7654Enable register			

PIO7654Status - RW – 8 bits - [PM_Reg: A9h]			
Field Name	Bits	Default	Description
ProgramIo4Status	0	0b	Programmable IO 4 status bit; write 1'b1 to clear the status bit
ProgramIo5Status	1	0b	Programmable IO 5 status bit; write 1'b1 to clear the status bit
ProgramIo6Status	2	0b	Programmable IO 6 status bit; write 1'b1 to clear the status bit
ProgramIo7Status	3	0b	Programmable IO 7 status bit; write 1'b1 to clear the status bit
ProgramPciConfig0Status	4	0b	Programmable pci config trap 0 status bit, write 1'b1 to clear the status.
ProgramPciConfig1Status	5	0b	Programmable pci config trap 1 status bit, write 1'b1 to clear the status
ProgramPciMem0Status	6	0b	Programmable pci memory trap 0 status bit, write 1'b1 to clear the status
ProgramPciMem1Status	7	0b	Programmable pci memory trap 1 status bit, write 1'b1 to clear the status
PIO7654Status register			

ProgramPciConfigIndex - RW – 8 bits - [PM_Reg: AAh]			
Field Name	Bits	Default	Description
ProgramPciConfigSel	0	0b	There are two pci configuration traps. Software sets this bit to select which one to program. This bit will affect PMIO_AA and PMIO_AB 0: ProgramPciConfig0; 1: ProgramPciConfig1
ProgramPciConfigSelBus	0	0b	This bit selects the contents in PMIO_AB 0: Device/function number; 1: Bus number
ProgramPciConfigIndex	7:2	00h	This corresponds to the pci config address bits [7:2]
ProgramPciConfigIndex register			

ProgramPciConfigBus - RW – 8 bits - [PM_Reg: ABh]			
Field Name	Bits	Default	Description
If ProgramPciConfigSelBus=0			
ProgramPciConfigFuncNum	2:0	000b	This corresponds to the pci config function number
ProgramPciConfigDevNum	7:3	00000b	This corresponds to the pci config device number
If ProgramPciConfigSelBus=1			
ProgramPciConfigBusNum	7:0	00h	This corresponds to the pci config bus number
ProgramPciConfigBus register			

ProgramPciMemAddr - RW – 8 bits - [PM_Reg: ACh:AFh]			
Field Name	Bits	Default	Description
ProgramPciMemSel	0	0b	There are two pci memory traps. Software sets this bit to select which one to program. This bit will affect PMIO_AC:AF 0: ProgramPciMem0 1: ProgramPciMem1
ProgramPciMemAddr	31:1	00h	This corresponds to the pci memory address bits [31:1]
ProgramPciMemAddr register			

StrapStatus - RW – 24 bits - [PM_Reg:B1:B0h]			
Field Name	Bits	Default	Description
StrapStatus/OverrideStrap Values	14:0	--	This 15-bit returns the strap values of the chip if ReadStrap=1 or the new settings to apply upon the next reset if ReadStrap=0. Bit [0]: RomStrap[0] Bit [1]: RomStrap[1] Bit [2]: IMCEnable Bit [3]: BootFailTmrEn Bit [4]: ClkGen Bit [5]: DefaultMode Bit [6]: Not used Bit [7]: I2cRomStrap Bit [8]: AcpiBclkBypStrap Bit [9]: IdePllBypStrap Bit [10]: PciPllBypStrap Bit [11]: ShortReset Bit [12]: SATAClkSrcFlip Bit [13]: Fast I2cClk Bit [14]: Not used
Reserved	15		
StrapStatus register			

MiscControl3 - RW – 8 bits - [PM_Reg:B2]			
Field Name	Bits	Default	Description
FcForceHoldRstEn	0	0b	Default at power on this bit force holds IDE and FC's reset, until software comes and programs this bit. 0: Force holds reset 1: Releases force hold on reset
FcReserved	2:1	00	These bits are reserved for future FC usage
SetImcGpio3AsIdeRstB	3	0b	0: Configure IMC_GPIO3 as IDE_RST# 1: Configure it as IMC_GPIO3 or FC_RST# (it is FC_RST# if flash controller is enabled)
FcClkGenSel	4	0b	The SP5100 has two methods to generate the flash controller clocks. 0: Method 1 (glitch free clock when BCh is changed) 1: Method 2 (requires software to stop the clock first before it can change the clock frequency)
AllowLdtStpAsOut	5	0b	0: AllowLdtStp is an input to SP5100 1: AllowLdtStp is an output from the SP5100. This is used by SB to indicate DMA traffic to the NB. This feature is to be used with the RS740/RS790 + Griffin CPU
ChangeStrap	6	0b	When set to 1, the overriding values defined in indexes B1:B0 will take effect upon the next reset.
ReadStrap	7	0b	When set to 1, indexes B1:B0 will always return the actual captured strap values. When set to 0, indexes B1:B0 returns the values that are be used to override the original straps. However, this overriding function is only enabled when ChangeStrap (bit [6]) is set and it will not take effect until the next reset. Basically this bit "ReadStrap" acts as a selection bit to two different sets of registers; one points to the actual captured straps while the other points to the overriding values.
MiscControl3 register			

C2Count - R – 8 bits - [PM_Reg: B3h]			
Field Name	Bits	Default	Description
C2Count	7:0	00h	The value shows the amount of time the CPU spends in C2. Each increment represents approximately 0.39% (1/256). This register is updated by HW automatically every second
C2Count register			

C3Count - R – 8 bits - [PM_Reg: B4h]			
Field Name	Bits	Default	Description
C3Count	7:0	00h	The value shows the amount of time the CPU spends in C3. Each increment represents approximately 0.39% (1/256). This register is updated by HW automatically every second
C3Count register			

IMC_ASF_Fan_Temp_Enable – RW – 8 bits - [PM_Reg: B6h]			
Field Name	Bits	Default	Description
IMC_Fan0_Enable	1	0b	Enables the interrupt when fan0 speed run slow
IMC_Fan1_Enable	1	0b	Enables the interrupt when fan1 speed run slow
IMC_Fan2_Enable	2	0b	Enables the interrupt when fan2 speed run slow
IMC_Fan3_Enable	3	0b	Enables the interrupt when fan3 speed run slow
IMC_Temp0_Enable	4	0b	Enables the interrupt when Temp0 is out of limit
IMC_Temp1_Enable	5	0b	Enables the interrupt when Temp1 is out of limit
IMC_Temp2_Enable	6	0b	Enables the interrupt when Temp2 is out of limit
IMC_Temp3_Enable	7	0b	Enables the interrupt when Temp3 is out of limit
IMC_ASF_Fan_Temp_Enable register			

IMC_Volt_Enable – RW – 8 bits - [PM_Reg: B7h]			
Field Name	Bits	Default	Description
IMC_Volt0_Enable	0	0b	Volt0 sensor to IMC interrupt enable. When set, a status of 1 in Volt0 sensor will trigger an interrupt to IMC
IMC_Volt1_Enable	1	0b	Volt1 sensor to IMC interrupt enable. When set, a status of 1 in Volt1 sensor will trigger an interrupt to IMC
IMC_Volt2_Enable	2	0b	Volt2 sensor to IMC interrupt enable. When set, a status of 1 in Volt2 sensor will trigger an interrupt to IMC
IMC_Volt3_Enable	3	0b	Volt3 sensor to IMC interrupt enable. When set, a status of 1 in Volt3 sensor will trigger an interrupt to IMC
IMC_Volt4_Enable	4	0b	Volt4 sensor to IMC interrupt enable. When set, a status of 1 in Volt4 sensor will trigger an interrupt to IMC
IMC_Volt5_Enable	5	0b	Volt5 sensor to IMC interrupt enable. When set, a status of 1 in Volt5 sensor will trigger an interrupt to IMC
IMC_Volt6_Enable	6	0b	Volt6 sensor to IMC interrupt enable. When set, a status of 1 in Volt6 sensor will trigger an interrupt to IMC
IMC_Volt7_Enable	7	0b	Volt7 sensor to IMC interrupt enable. When set, a status of 1 in Volt7 sensor will trigger an interrupt to IMC
IMC_Volt_Enable register			

IMC_GroupA_Enable – RW – 8 bits - [PM_Reg: B8h]			
Field Name	Bits	Default	Description
IMC_Gevent0_Enable	0	0b	GEVENT0 to IMC interrupt enable. When set, a status of 1 in GEVENT0 will trigger an interrupt to IMC
IMC_Gevent1_Enable	1	0b	GEVENT1 to IMC interrupt enable. When set, a status of 1 in GEVENT1 will trigger an interrupt to IMC
IMC_Gevent2_Enable	2	0b	GEVENT2 to IMC interrupt enable. When set, a status of 1 in GEVENT2 will trigger an interrupt to IMC
IMC_Gevent3_Enable	3	0b	GEVENT3 to IMC interrupt enable. When set, a status of 1 in GEVENT3 will trigger an interrupt to IMC

IMC_GroupA_Enable – RW – 8 bits - [PM_Reg: B8h]			
Field Name	Bits	Default	Description
IMC_Gevent4_Enable	4	0b	GEVENT4 to IMC interrupt enable. When set, a status of 1 in GEVENT4 will trigger an interrupt to IMC
IMC_Gevent5_Enable	5	0b	GEVENT5 to IMC interrupt enable. When set, a status of 1 in GEVENT5 will trigger an interrupt to IMC
IMC_Gevent6_Enable	6	0b	GEVENT6 to IMC interrupt enable. When set, a status of 1 in GEVENT6 will trigger an interrupt to IMC
IMC_Gevent7_Enable	7	0b	GEVENT7 to IMC interrupt enable. When set, a status of 1 in GEVENT7 will trigger an interrupt to IMC
IMC_GroupA_Enable register			

IMC_GroupB_Enable – RW – 8 bits - [PM_Reg: B9h]			
Field Name	Bits	Default	Description
IMC_GPM0_Enable	0	0b	GPM0 to IMC interrupt enable. When set, a status of 1 in GPM0 will trigger an interrupt to IMC
IMC_GPM1_Enable	1	0b	GPM1 to IMC interrupt enable. When set, a status of 1 in GPM1 will trigger an interrupt to IMC
IMC_GPM2_Enable	2	0b	GPM2 to IMC interrupt enable. When set, a status of 1 in GPM2 will trigger an interrupt to IMC
IMC_GPM3_Enable	3	0b	GPM3 to IMC interrupt enable. When set, a status of 1 in GPM3 will trigger an interrupt to IMC
IMC_GPM4_Enable	4	0b	GPM4 to IMC interrupt enable. When set, a status of 1 in GPM4 will trigger an interrupt to IMC
IMC_GPM5_Enable	5	0b	GPM5 to IMC interrupt enable. When set, a status of 1 in GPM5 will trigger an interrupt to IMC
IMC_GPM6_Enable	6	0b	GPM6 to IMC interrupt enable. When set, a status of 1 in GPM6 will trigger an interrupt to IMC
IMC_GPM7_Enable	7	0b	GPM7 to IMC interrupt enable. When set, a status of 1 in GPM7 will trigger an interrupt to IMC
IMC_GroupB_Enable register			

IMC_SMBus_Enable – RW – 8 bits - [PM_Reg: BAh]			
Field Name	Bits	Default	Description
IMC_SMBus_Enable	0	0b	Set to 1 to enable smbus interrupt to IMC
ASFMasterIntrEn	1	0b	Enables ASF SM Master interrupt to IMC
ASFMasterSMIEn	2	0b	Enables ASF SM master SMI to host (BIOS)
ASFSlaveIntrEn	3	0b	Enables ASF SM Slave interrupt to IMC
ASFSlaveSMIEn	4	0b	Enables ASF SM Slave SMI to host (BIOS)
HWMTestModeEn	5	0b	0: Enable HWM normal mode 1: Enable HWM test mode Test purpose only. Software should not program this bit under normal operating condition.
HideSmbus	6	0b	0: Smbus PCI config space is exposed to OS. Smbus is function 0 and LPC bridge is function 3 1: Smbus PCI config space is hidden from OS. Here LPC bridge will become function 0
IMC_ASF_Enable	7	0b	Enable the ASF interrupt to IMC
IMC_SMBus_Enable register			

IMC_ACPI_Enable – RW – 8 bits - [PM_Reg: BBh]			
Field Name	Bits	Default	Description
IMC_GA20_Enable	0	0b	Enables GA20 function signal from IMC
IMC_KBRST_Enable	1	0b	Enables KBRST# function from IMC
IMC_IRQ1_Enable	2	0b	Enables IRQ1 function from IMC
IMC_IRQ12_Enable	3	0b	Enables IRQ12 function from IMC
IMC_SMI_Enable	4	0b	Enables IMC to generate SMI to BIOS

IMC_ACPI_Enable – RW – 8 bits - [PM_Reg: BBh]			
Field Name	Bits	Default	Description
MaskLpcRst*	5	0b	For ASIC A14 and A15 only: when set, LPC registers become sticky (i.e., it will not be reset to default values during sleep). This is meant to let IMC_GPIO retain values.
NewClk14En*	6	0b	For ASIC A14 and A15 only: when set, SB will use a new divider to generate a more precise 14MHz clock for internal use. This is to address the HPET precision. When set to 0, 14MHz clock is 14.31878Mhz. When set to 1, the clock is 14.31818MHz.
ServerCEn*	7	0b	For ASIC A14 and A15 only: when set, ACPI block will count the number of HALT messages from CPU and go into C state automatically when all CPUs are in HALT state (use in conjunction with PMIO_C9).
IMC_ACPI_Enable register. Bits marked by "*" are only available for ASIC revision A14 and A15. On ASIC A11/12, they cannot be written, and reading them will yield undefined values.			

FC_Clk_Sel – RW – 8 bits - [PM_Reg: BCh]			
Field Name	Bits	Default	Description
FC_Clk_Sel	5:0	000b	When PM_Reg B2[4] = 0, only the lower 3 bits control the flash controller clock frequency. The 2x and 1x clocks are: 000b: 66/33 Mhz 001b: 80/40Mhz 010b: 100/50Mhz 011b: 133/66Mhz 100b: 160/80Mhz 101b: 200/100Mhz 11xb: Reserved When PM_Reg B2[4] = 1, then the frequency are controlled this equation: $1200/(FC_Clk_Sel+2)$. Normal operation should only be limited to 200Mhz for the 2x clock. Valid values are limited between 4 and 60d
SetFcClk80	6	0b	Setting this bit will cause the flash controller clock to be 80Mhz. 1: Use bits [5:0] of this register to control the flash controller clock speed 0: Ignore bits [5:0] and set FC clock to 80Mhz
FC_Clk_StopB	7	0b	Clock enable bit for flash controller. This is meant for software to stop the clock, change the frequency, and then restart the clock. 0: Stop the clock 1: Enable the clock
FC_Clk_Sel register			

SysClkCfg1 – RW – 8 bits - [PM_Reg: BDh]			
Field Name	Bits	Default	Description
Clk1Cfg	1:0	2'b00	Defines 25M_48M_66M clock frequency 00: 66Mhz 01: 48Mhz 10: 25Mhz 11: 48Mhz
Clk2Cfg	3:2	2'b00	Defines USBCLK/14M_25M_48M_OSC clock frequency 00: Tristate 01: 14Mhz 10: 25Mhz 11: 48Mhz

SysClkCfg1 – RW – 8 bits - [PM_Reg: BDh]			
Field Name	Bits	Default	Description
UsbClkCfg	4	0b	Defines whether USB uses the internal or external 48Mhz clock 0: External 1: Internal
Clk1OutEnB	5	0b	14M_25M_48M clock output enable bar 0: Enable 1: Eisable
Clk2OutEnB	6	0b	48M clock output enable bar; 0: Enable 1: Disable This bit only has meaning if UsbClkCfg is set
HtClkSel	7	0b	CPU HT clock frequency select 0: 200Mhz 1: 100Mhz
SysClkCfg1 register			

Note: PMIO_C0:C2 are meant to be a faster way for BIOS to determine the source of SMI instead of searching various registers

SmiIndicator0 - R – 8 bits - [PM_Reg: C0h]			
Field Name	Bits	Default	Description
SmiIndicator0	7:0	-	This register is a read only register and is meant to help BIOS to search the SMI source quicker Bit [0] = 1 means the SMI source is coming from PM_Reg0F Bit [1] = 1 means the SMI source is coming from CMS (IO C50/C51, Index02) Bit [2] = 1 means the SMI source is coming from PM_RegA9 Bit [3] = 1 means the SMI source is coming from PM_Reg1D Bit [4] = 1 means the SMI source is coming from PM_Reg07 Bit [5] = 1 means the SMI source is coming from PM_Reg06 Bit [6] = 1 means the SMI source is coming from PM_Reg05 Bit [7] = 1 means the SMI source is coming from PM_Reg01
SmiIndicator0 register			

SmiIndicator1 - R – 8 bits - [PM_Reg: C1h]			
Field Name	Bits	Default	Description
SmiIndicator1	4:0	-	This register is a read only register and is meant to help BIOS to search the SMI source quicker Bit [0] = 1 means the SMI source is coming from PM_Reg5F Bit [1] = 1 means the SMI source is coming from PM_Reg5D Bit [2] = 1 means the SMI source is coming from PM_Reg5C Bit [3] = 1 means the SMI source is coming from PM_Reg5B Bit [4] = 1 means the SMI source is coming from PM_Reg5A
ASFsmi	5	0b	Indicates a smi event from ASF master or slave module
Reserved	7:6		
SmiIndicator1 register			

SmiIndicator2 - R – 8 bits - [PM_Reg: C2h]			
Field Name	Bits	Default	Description
SmiIndicator2	7:0	-	This register is a read only register and is meant to help BIOS to search the SMI source quicker Bit [0] = 1 means the SMI source is coming from HWM (PMIO2) Bit [1] = 1 means the SMI source is coming from AMDSI (PMIO2) Bit [2] = 1 means the SMI source is coming from the fan monitor (PMIO2) Bit [3] = 1 means the SMI source is coming from RTC VRT (IO 70/71, index 0D, bit 7) Bit [4] = 1 means the SMI source is coming from IMC Bit [5] = 1 means the SMI source is coming from IntruderAlert Bit [6] = 1 means the SMI source is coming from SCI Bit [7] = 1 means the SMI source is coming from ACPI_GEVENT_STATUS
SmiIndicator2 register			

PostCode – R – 8 bits - [PM_Reg:C3h]			
Field Name	Bits	Default	Description
PostCode	7:0		This register returns the last post code recorded in IO 80 or 1080h
PostCode register			

ClkbufDrvStr_A – RW – 8 bits - [PM_Reg: C4h]			
Field Name	Bits	Default	Description
ClkBufDrvStr	1:0	2'b01	Defines the drive strength of high speed diff clocks
Reserved	2	1'b1	
ClkBufPwrDn	3	1'b0	Set to 1 to power down all high speed clock buffers
ClkBufTestEn	6:4	3'b101	Debugging purpose only
Reserved	7	1'b0	
ClkBufDrvStr_A register			

ClkbufDrvStr_B – RW – 8 bits - [PM_Reg: C5h]			
Field Name	Bits	Default	Description
TermResistorEn	0	1'b1	Enables the high speed clock termination resistors. Set 0 to disable
Reserved	7:1	7'h2A	
ClkBufDrvStr_B register			

ClkbufDrvStr_C – RW – 8 bits - [PM_Reg: C6h]			
Field Name	Bits	Default	Description
Reserved	7:0	8'h55	
ClkBufDrvStr_C register			

spare – RW – 8 bits - [PM_Reg: C7h]			
Field Name	Bits	Default	Description
spare	7:0	8'h00	
spare register			

HT_TestControl – RW – 8 bits - [PM_Reg:C8h]			
Field Name	Bits	Default	Description
HT_IdleInterval	2:0	000b	This field defines the idle time between the two LDTSTP#. <ul style="list-style-type: none"> 000: Unlimited time 001: 1 010: 2 011: 4 100: 8 101: 16 110: 32 111: 64 Unit of time (μ s or ms) is determined by HT_TimeInterval
HT_TimeInterval	3	0b	This bit defines HT_IdleInterval in millisecond or microsecond. <ul style="list-style-type: none"> 0: Microsecond 1: Millisecond
HT_AssertInterval	6:4	000b	This field defines the assertion time <ul style="list-style-type: none"> 000: 1 μs 001: 2 μs 010: 4 μs 011: 8 μs 100: 16 μs 101: 32 μs 110: 64 μs 111: 128 μs (Note: Values are always in μ s regardless of HT_TimeInterval setting.)
HT_BIST_Start	7	0b	This bit is write only. Always return 0 when read. Writing to this bit will start the K8 BIST. Basically SB will assert LDTSTP# for interval defined by HT_AssertInterval, wait HT_TimeInterval, then assert LDTSTP# again
HT_TestControl register			

MultiK8Control – RW – 8 bits - [PM_Reg:C9h]			
Field Name	Bits	Default	Description
NumOfHalt	3:0	0001b	This registers define the number of HALT messages to trigger C1e.
CountHaltMsgEn	4	0b	When this bit is set, SB will monitor the number of HALT messages from the CPU to trigger C1e.
Reserved	5	0b	
HT_DelayStartTime	7:6	00b	This registers define the delay start time associated with the function in C8h. The values are in microseconds. This is to allow the write to C8h[7] to be complete before SB should execute the test function.
MultiK8Control register			

ClkPinControl – RW – 8 bits - [PM_Reg:CAh]			
Field Name	Bits	Default	Description
ClockPinControl	6:0	7'b0	These are the output disable for the differential clock pins Bit [0]: Not used Bit [1]: NB_HT_CLK Bit [2]: PCIE_GPP0_CLK Bit [3]: PCIE_GPP1_CLK Bit [4]: PCIE_GPP2_CLK Bit [5]: PCIE_GPP3_CLK Bit [6]: PCIE_PPLL_CLK 0: Enable the clock 1: Disable the clock
AlinkClkSel	7	1'b0	0: Uses the 400Mhz clock from PLL to derive the 66Mhz Alink clock 1: Uses 64Mhz from PLL as the internal Alink clock this is in case the crystal is too fast and the clock is slightly less than 30ns on the PCICLK (PCICLK is derived from the internal Alink clock)
ClkControl register			

AltStrapControl – RW – 8 bits - [PM_Reg:CBh]			
Field Name	Bits	Default	Description
UseAltStrapControl	0	1'b0	When set, it will use the config bits from index CCh and CDh to override the EpromStraps
Clk66_48_25TestMode	1	1'b0	When set, Clk66_48_25 becomes a test port. Debugging purpose only. This bit should not be set under normal operating condition
DisblePciRom	2	1'b0	The SP5100 has an option to boot from PCI memory on the first boot. The usage of this option is to allow the BIOS to boot from the PCI memory and shadow it in the system memory. Here the BIOS is supposed to initiate a warm reset to cause the PCI memory option to be disabled and switch the SB back to the flash defined by the ROM straps. Next the BIOS will copy the content from the shadow memory onto the SPI flash. This bit allows the BIOS to switch from PCI memory back to the normal flash without initiating a reset. (This applies to ASIC revision A12 only).
OverrideClk14	3	1'b0	The SP5100 A12 will output a 14Mhz clock on the 14_25_48Mhz when internal clock mode is enabled. This bit is to override it. (This applies to ASIC revision A12 only).
OverrideKBEnable	4	1'b0	The SP5100 A12 will enable KB_RST# function by default when internal clock mode is enabled. This bit is to override it. (This applies to ASIC revision A12 only).
AutoStutterTimerEn	5	1'b0	When set, SB will automatically stutter the CPU C1e state based on the timer defined by SMBUS PCI 5C[22:16]. When this bit is set, SmartVolt becomes a stutter timer and the configuration bits in SMBUS PCI 5C other than bits [22:16] should be left as 0. This feature is intended to be used with server CPU.
AutoStutterTimeSel	6	0b	When set, timer tick is on 1ms increments instead of two ms
Reserved	7	0b	
AltStrapControl register			

EpromStrapIndex – RW – 8 bits - [PM_Reg:CCh]			
Field Name	Bits	Default	Description
EpromStrapIndex	7:0	8'h00	EpromStraps are used to program the SB in case certain default values that control the PCIe® PHY and CG PLL are not correct. SP5100 has two methods to program these straps: through the EPROM interface or through this index (CCh) and data (CDh) ports. Write to this port sets the initial value of the index. Writing to the EpromStrapData port will auto-increment this index. Programming through the index/data port will not take effect until the next reset
EpromStrapIndex register			

EpromStrapData – RW – 8 bits - [PM_Reg:CDh]			
Field Name	Bits	Default	Description
EpromStrapData	7:0	8'h00	EpromStraps are used to program the SB in case certain default values that control the PCIe PHY and CG PLL are not correct. SP5100 has two methods to program these straps: through the EPROM interface or through this index (CCh) and data (CDh) ports. Writing to the EpromStrapData port will auto-increment the index at PMIO_CCh. Programming through the index/data port will not take effect until the next reset
EpromStrapData register			

spare – RW – 8 bits - [PM_Reg: CEh]			
Field Name	Bits	Default	Description
spare	7:0	8'h00	
spare register			

PLLControl – RW – 8 bits - [PM_Reg:CFh]			
Field Name	Bits	Default	Description
HWMTestEn	3:0	4'b0	Test configuration. When set, it turned test features of ADC (voltage monitor)
CfgRefClkSel	5:4	2'b00	By default, CG_PLL2 reference clock divider is set by the strap pin. These two bits allow overwrite. If the reference clock is 25Mhz, then the default clock divider value (txpll_refdiv2) is 2'b00. For 100Mhz reference clock, the value is 2'b10. These two bits is logically XOR with the default clock divider value
CfgNbDsPllSel	6	1'b0	This bit controls CG_PLL1 nb_dspll_clk_sel port
CfgCg2SSEn	7	1'b0	Spread Spectrum enable bit for PLL CG2
PLLControl register			

SataClkControl – RW – 8 bits - [PM_Reg:D0h]			
Field Name	Bits	Default	Description
CfgCg2EnableB	0	1'b0	0: Enable CG_PLL2 1: Disable CG_PLL2
CfgSataClkSel	2:1	2'b00	Clock frequency select from CG_PLL2 00: PLL 25Mhz 01: PLL 100Mhz 10: Buffered 25Mhz 11: Buffered 100Mhz
SataClkDivSel	4:3	2'b00	This controls the reference clock selection and divider inside the SATA PHY. Final function TBD by Christine Wang
Reserved	7:5	3'b000	
SataClkControl register			

PLLParameter1 – RW – 8 bits - [PM_Reg:D1h]			
Field Name	Bits	Default	Description
CgPll1_Pcie_ClkEnB_Invert	0	1'b0	0: Use the strap value to determine whether PCIe® 100Mhz clock should be enabled from CG PLL1. Normally PCIe clock is disabled when SB is strapped to use external clock and enabled when strapped to integrated clock 1: Invert the strap value that controls the PCIe clock enable bit
CgPll1_Ht_ClkEnB_Invert	1	1'b0	0: Use the strap value to determine whether HT 200Mhz clock should be enabled from CG PLL1. Normally this clock is disabled when SB is strapped to use external clock and enabled when strapped to integrated clock 1: Invert the strap value that controls the CPU HT clock enable bit
CgPll1_Test_ClkEnB	2	1'b0	0: Enable the CG PLL1 test node for probing 1: Disable the CG PLL1 test node for probing
CgPll1_IdePci_ClkEnB	3	1'b0	0: Enable CG PLL1 400Mhz clock 1: Disable CG PLL1 400Mhz clock
CgPll1_Alink_ClkEnB	4	1'b0	0: Enable the 64Mhz clock from CG PLL1 1: Disable the 64Mhz clock from CG PLL1 this clock is meant to replace the internal 66Mhz in case the crystal is too fast (the clock becomes less than 15ns)
CgPll1_48M_ClkEnToggle	5	1'b0	The clock from CG PLL1 is enabled by default if we are in integrated clock mode; otherwise, it is disabled. This bit allows software to flip the setting.
CgPll1_25M_ClkEnB	6	1'b0	0: Enable the 25Mhz clock from CG PLL1 1: Disable the 25Mhz clock from CG PLL1 this bit should be set since it is not expected to use this clock
Cg_Pll1_14M_ClkEnB	7	1'b0	0: Enable the 14Mhz clock from CG PLL1 1: Disable the 14Mhz clock from CG PLL1 this bit should be set since it is not expected to use this clock
PLLParameter1 register			

PLLParameter2 – RW – 8 bits - [PM_Reg:D2h]			
Field Name	Bits	Default	Description
CgPll1_Fc_ClkEnB	0	1'b0	0: Enable the flash controller clock from CG PLL1 1: Disable the flash controller clock from CG PLL1
CgPll2_Pcie_ClkEnB_Invert	1	1'b0	0: Use the strap value to determine whether PCIe 100Mhz clock should be enabled from CG PLL2. Normally this clock is disabled when SB is strapped to use external clock and enabled when strapped to integrated clock. This clock should be turned off since it is not expected to use non-spread clock for the PCIe. 1: Invert the strap value that controls the PCIe enable bit.
CgPll2_Ht_ClkEnB_Invert	2	1'b0	0: Use the strap value to determine whether HT 200Mhz clock should be enabled from CG PLL2. Normally PCIe clock is disabled when SB is strapped to use external clock and enabled when strapped to integrated clock. This clock should be turned off since it is not expected to use non-spread clock for the CPU HT 1: Invert the strap value that controls the HT CPU enable bit
CgPll2_Usb_ClkEnB_Invert	3	1'b0	0: Use the strap value to determine whether USB 48Mhz clock should be enabled from CG PLL2. Normally this clock is disabled when SB is strapped to use external clock and enabled when strapped to integrated clock. 1: Invert the strap value that controls the USB 48Mhz enable bit

PLLParameter2 – RW – 8 bits - [PM_Reg:D2h]			
Field Name	Bits	Default	Description
CgPll2_Sata_ClkEnB_Invert	4	1'b0	0: Use the strap value to determine whether Sata 100/25Mhz clock should be enabled from CG PLL2. Normally this clock is disabled when SB is strapped to use external clock and enabled when strapped to integrated clock. 1: Invert the strap value that controls the SATA 25/100Mhz enable bit
CgPll2_IdePci_ClkEnB	5	1'b0	0: Enable CG PLL2 400Mhz clock 1: Disable CG PLL2 400Mhz clock Note: This bit should be set since it is not expected to use this clock
CgPll2_Alink_ClkEnB	6	1'b0	0: Enable the 64Mhz clock from CG PLL2 1: Disable the 64Mhz clock from CG PLL2 this bit should be set to turn off the clock since it is not expected to use this clock at all
CgPll2_NbDspIi_ClkEnB	7	1'b0	0: Enable the nb display clock from CG PLL2 1: Disable the nb display clock from CG PLL2 this bit should be set to turn off the clock since it is not expected to use this clock at all
PLLParameter2 register			

PLLParameter3 – RW – 8 bits - [PM_Reg:D3h]			
Field Name	Bits	Default	Description
CgPll2_48M_ClkEnB	0	1'b0	0: Enable the 48Mhz clock from CG PLL2 1: Disable the 48Mhz clock from CG PLL2
CgPll2_25M_ClkEnB	1	1'b0	0: Enable the 25Mhz clock from CG PLL2 1: Disable the 25Mhz clock from CG PLL2
Cg_Pll2_14M_ClkEnB	2	1'b0	0: Enable the 14Mhz clock from CG PLL2 1: Disable the 14Mhz clock from CG PLL2
CgPll2_Fc_ClkEnB	3	1'b0	0: Enable the flash controller clock from CG PLL2 1: Disable the flash controller clock from CG PLL2
FcClkSrc	4	1'b0	0: Select FC clock from CG_PLL1 1: Select FC clock from CG_PLL2
CLKREQ0_Enable	5	1'b0	1: Enable GPIO0 as CLKREQ0# function 0: Disable GPIO0 as CLKREQ# function
CLKREQ1_Enable	6	1'b0	1: Enable GPIO39 as CLKREQ1# function 0: Disable GPIO39 as CLKREQ1# function
CLKREQ2_Enable	7	1'b0	1: Enable GPIO40 as CLKREQ2# function 0: Disable GPIO40 as CLKREQ2# function
PLLParameter3 register			

PLLParameter4 – RW – 8 bits - [PM_Reg:D4h]			
Field Name	Bits	Default	Description
CLKREQ3_Enable	0	1'b0	1: Enable GPIO40 as CLKREQ3# function 0: Disable GPIO40 as CLKREQ3# function
Reserved	5:1	5'h0	
AltClk14En	6	1'b0	Set to 1 to enable 25M_48M_66M_OSC pin as the input for 14MHz clock source for SB's timers (such as 8254, ACPI timer, and HPET). If AltClk14En is enabled, OSCPwrDown should be left at the default value of '1'b, and the following fields -- UseOscAsClk14* , UsePll2ForClk14* , Pll2UseOsc in PMIO reg 9F, and Precise14MhzEnable in PM_REG 53 -- should be left at the default value of 0.
OscPwrDown	7	1'b0	1: Power down the 25Mhz oscillator buffer 0: Enable the 25Mhz oscillator buffer
PLLParameter4 register			

CpuRstCtrl – RW – 8 bits - [PM_Reg:D5h]			
Field Name	Bits	Default	Description
CpuRstTime	1:0	2'b00	00: CPURST# is deasserted 2ms after PciRst# 01: CPURST# is deasserted in the same time as PciRst# 10: CPURST# is deasserted 2ms before PciRst# 11: CPURST# is deasserted 2ms after PciRst#
Reserved	5:2	4'h0	
ASFSlaveSCIEn	6	1'b0	Set to 1 to route ASF Slave interrupt to GEVENT13
ASFMasterSCIEn	7	1'b0	Set to 1 to route ASF Master interrupt to GEVENT13
CpuRstCtrl			
Note: GEVENT13 is internal Interrupt signal in ACPI. This signal is not routed to any physical pin on the SP5100.			

ASFClkCtrl – RW – 8 bits - [PM_Reg:D6h]			
Field Name	Bits	Default	Description
ASFClkSel	2:0	2'b00	000: ~104kHz 001: ~206kHz 010: ~328kHz 011: ~409kHz 100: ~649kHz 101: ~807kHz 110: ~919kHz 111: ~1MHz
Reserved	6:3	4'h0	
ASFFastClkEn	7	1'b0	Set to 1 to enable ASF master to run on fast clk selected in bits [2:0] of the register. If set to 0, ASF master run on rtc 32K clock.
ASFClkCtrl			

MiscD7 – RW – 8 bits - [PM_Reg:D7h]			
Field Name	Bits	Default	Description
Pme_Turn_Off_On	0	1'b0	Set to 1 to generate PME_TURN_OFF message to NB When receiving Thermtrip#/4-s shutdown/Shutdown Pin/ASF Shutdown request.
PmeHp2PcieWakeSts	1	1'b0	Set to 1 to allow Pcie_wake_sts to be set when receiving Pme & HotPlug message from NB.
Gevent5Sel	2	1'b0	Set to 1 to allow Gevent5 to be used as a Gpio pin.
ForceK8	3	1'b0	Set to 1 to configure Hc as K8 mode.
RstAcpi	4	1'b0	Set to 1 to reset Acpi S5 registers. The bit should be used by IMC only.
RstBtn2Acpi	5	1'b0	Set to 1 to not allow UserButton to reset Acpi. The bit should be used by lmc only.
Pcie_Wake_Dis_Debug	6	1'b0	Set to 1 to mask off the input to Pcie_Wak_sts if Pcie_Wake_Dis bit is set to 1.
TempAverage	7	1'b0	Set to 1 to enable average function when doing temperature reading form HWM.
MiscD7			

2.3.3.3 ACPI Registers

Register Name	Offset Address*
Pm1Status	00h
Pm1Enable	02h
PmControl	00h
PmaControl	00h
TmrValue/ETmrValue	00h
CLKVALUE	00h
PLv2	04h
PLv3	05h
PLv4	06h
EVENT_STATUS	00h
EVENT_ENABLE	04h

Note: The offset addresses listed here for the ACPI registers belong to different apertures/decodes. Check the register descriptions for details.

Pm1Status - RW - 16 bits - [AcpiPmEvtBlk:00h]			
Field Name	Bits	Default	Description
TmrStatus	0	0b	Timer carry status bit. This bit gets set anytime the 23 rd /31 st bit of 24/32 bit counter changes (whenever the MSB changes from low to high or high to low. While TmrEn and TmrStatus are set, an interrupt event is raised). [Read-only]
Reserved	3:1		
BmStatus	4	0b	Bus master status bit. This bit is set any time a system bus master requests the system bus, and can only be cleared by writing an one to this bit position.
GblStatus	5	0b	This bit is set when an SCI is generated due to the BIOS wanting the attention of the SCI handler. This is set by writing 1 to PM_Reg: 0Eh bit [1].
Reserved	7:6		
PwrBtnStatus	8	0b	Power button status bit
Reserved	9		
RtcStatus	10	0b	This bit is set when RTC generates an alarm.
Reserved	13:11		
PciExpWakeStatus	14	0b	This bit is set by hardware to indicate that the system woke due to a PCI Express® wakeup event.
WakeStatus	15	0b	This bit is set when the system is in the sleep state and a wake-up event occurs.

This register is located at the base address defined by AcpiPmEvtBlk.

Pm1Enable - RW - 16 bits - [AcpiPmEvtBlk:02h]			
Field Name	Bits	Default	Description
TmrEn	0	0b	This is the timer carry interrupt enable bit. When this bit is set then an SCI event is generated anytime the TmrStatus is set. When this bit is reset then no interrupt is generated when the TmrStatus bit is set.
Reserved	4:1		
GblEn	5	0b	If this bit is set, SCI is raised whenever both GblEn and GblStatus are true.
Reserved	7:6		
PwrBtnEn	8	0b	If this bit is set, SCI is generated whenever PwrBtnStatus is true.
Reserved	9		
RtcEn	10	0b	RTC enable. If this bit is set, SCI is generated whenever RtcStatus is true.
Reserved	13:11		

Pm1Enable - RW - 16 bits - [AcpiPmEvtBlk:02h]			
Field Name	Bits	Default	Description
PciExpWakeDis	14	1b	This bit disables the inputs to the PciExpWakeStatus from waking the system.
Reserved	15		
This register is located at the base address defined by AcpiPmEvtBlk.			

PmControl - RW - 16 bits - [AcpiPm1CntBlk:00h]			
Field Name	Bits	Default	Description
SCI_EN	0	0b	Selects the power management event to be either an SCI or SMI# interrupt for the following events. When this bit is set, then PM events will generate an SCI interrupt; otherwise, it will be SMI#.
BmRld	1	0b	If this bit is set, SCI is raised whenever there is a bus master active
GBL_RLS	2	0b	If PM IO x0E bit[0] is set, writing 1 to this bit will generate SMI# and set PM IO x0F bit[0]. This bit will always return 0.
Reserved	9:3		
SlpType	12:10	000b	Defines the sleep state the system enters when the SlpEn is set to one. This design currently implements 3 states: S1, S3, and S5
SlpEn	13	0b	This is a write-only bit and reads from it always return zero. If PM_Reg 04h bit7 SLP_SMI_EN is 0, setting this bit causes the system to sequence into the sleeping state associated with the SlpType fields programmed. If SLP_SMI_EN is 1, setting this bit causes SMI#. Writing 0 to this bit has no effect.
Reserved	15:14		
This register is located at the base address defined by AcpiPm1CntBlk.			

Pm2Control - RW - 8 bits - [AcpiPm2CntBlk:00h]			
Field Name	Bits	Default	Description
ARB_DIS	0	0b	System arbiter is disabled when this bit is set.
Reserved	7:1		
This register is located at the base address defined by AcpiPm2CntBlk.			

TmrValue/ETmrValue – R - 32 bits - [AcpiPmTmrBlk:00h]			
Field Name	Bits	Default	Description
TmrValue	31:0	-	This read-only field returns the running count of the power management timer.
This register is located at the base address defined by AcpiPmTmrBlk.			

CLKVALUE - RW - 32 bits - [CpuControl:00h]			
Field Name	Bits	Default	Description
Reserved	0		
ClkValue	3:1	000b	These bits define throttle interval for STPCLK# de-assertion 000b: 50% 001b: 12.5% 010b: 25% 011b: 37.5% 100b: 50% 101b: 62.5% 110b: 75% 111b: 87.5%
ThtEn	4	0b	This bit enables clock throttling as set in the ClkValue.
Reserved	31:5		
This register is located at the base address defined by CpuControl			

PLv12 - R - 8 bits - [CpuControl:04h]			
Field Name	Bits	Default	Description
PLv12	7:0	00h	Reads to this register return all zeros; writes to this register have no effect. Reads to this register generates a “enter C2 power” to the clock control logic (STPCLK logic).
This register is located at the base address defined by CpuControl			

PLv13 – R – 8 bits - [CpuControl:05h]			
Field Name	Bits	Default	Description
PLv13	7:0	00h	Reads to this register return all zeros; writes to this register have no effect. Reads to this register generates a “enter C3 power” to the clock control logic (STPCLK logic).
This register is located at the base address defined by CpuControl			

PLv14 – R – 8 bits - [CpuControl:06h]			
Field Name	Bits	Default	Description
PLv14	7:0	00h	Reads to this register return all zeros; writes to this register have no effect. Reads to this register generates a “enter C4 power” to the clock control logic (STPCLK logic).
This register is located at the base address defined by CpuControl			

EVENT_STATUS - RW - 32 bits - [AcpiGpe0Blk:00h]			
Field Name	Bits	Default	Description
GeventStatus	7:0	00h	These bits indicate the status of the eight general purpose event signals events to the SB
LEventStatus	8	0b	This bit indicates the status of the legacy power management logic implemented inside the SB.
TwarnStatus	9	0b	This bit indicates the Temperature Caution input.
Reserved	10		
USBStatus	11	0b	This bit indicates the PME# from the internal USB controller
IMC_Status	12	0b	This bit indicates the PME# from the internal IMC controller
OtherThermStatus	13	0b	This bit indicates the status of OtherTherm from NB, fan, etc.
GPM9Status	14	0b	This bit indicates the status of GPM[9] to SCI/Wakeup
PCleHotPlugStatus	15	0b	This bit indicates the status of PCleHotPlug
ExtEvent0Status	16	0b	This bit indicates the status of ExtEvent0 to SCI/Wakeup
ExtEvent1Status	17	0b	This bit indicates the status of ExtEvent1 to SCI/Wakeup
PClePmeStatus	18	0b	This bit indicates the PME# from PCI Express®
GPM0Status	19	0b	This bit indicates the status of GPM[0] to SCI/Wakeup
GPM1Status	20	0b	This bit indicates the status of GPM[1] to SCI/Wakeup
GPM2Status	21	0b	This bit indicates the status of GPM[2] to SCI/Wakeup
GPM3Status	22	0b	This bit indicates the status of GPM[3] to SCI/Wakeup
GPM8Status/CIR	23	0b	This bit indicates the status of GPM[8] or CIR (depends on PMIO55[1]) to SCI/Wakeup
Gpio0Status	24	0b	This bit indicates the status of GPIO0 (or WAKE#/GEVENT8 pin if PM IO Reg 84h bit1 =1) to SCI/wakeup
GPM4Status	25	0b	This bit indicates the status of GPM[4] to SCI/Wakeup
GPM5Status	26	0b	This bit indicates the status of GPM[5] to SCI/Wakeup
AzaliaStatus	27	0b	This bit indicates the status from the internal HD Audio controller
GPM6Status	28	0b	This bit indicates the status of GPM[6] to SCI/Wakeup
GPM7Status	29	0b	This bit indicates the status of GPM[7] to SCI/Wakeup
A11: Gpio2Status A12: Gpio2Status / Gpio66Status	30	0b	A11: This bit indicates the status of GPIO2 to SCI/wakeup A12: This bit indicates the status of GPIO2 or GPIO66; depending on PMIO_10h[7]. If PMIO_10h[7]=0, then it is routed to GPIO2. If PMIO_10h[7]=1, then it is GPIO66
SataSciStatus	31	0b	This bit indicates the status of SataSci to SCI/wakeup

EVENT_STATUS - RW - 32 bits - [AcpiGpe0Blk:00h]			
Field Name	Bits	Default	Description
This register is located at the base address defined by AcpiGpe0Blk.			

EVENT_ENABLE - RW - 32 bits - [AcpiGpe0Blk:04h]			
Field Name	Bits	Default	Description
GeventEnable	7:0	00h	These bits enable the GeventStatus to SCI output.
LeventEnable	8	0b	This bit enables LEventStatus to SCI generation.
TwarnEnable	9	0b	This bit enables TwarnStatus to SCI generation.
Reserved	10		
USBEnable	11	0b	This bit enables PME# from the internal USB controllers
ImcEnable	12	0b	This bit enables PME# from the internal IMC controllers
OtherThermEnable	13	0b	Enables bit for AcpiGpe0Blk, offset 00, bit [13] OtherThermStatus
GPM9Enable	14	0b	Enables bit for AcpiGpe0Blk, offset 00, bit [14] GPM9Status
PCleHotPlugEnable	15	0b	Enable bit for AcpiGpe0Blk, offset 00, bit [15] PCleHotPlugStatus
ExtEvent0Enable	16	0b	Enables bit for AcpiGpe0Blk, offset 00, bit [16] ExtEvent0Status
ExtEvent1Enable	17	0b	Enables bit for AcpiGpe0Blk, offset 00, bit [17] ExtEvent1Status
PClePmeEnable	18	0b	Enables bit for AcpiGpe0Blk, offset 00, bit [18] PClePmeStatus
GPM0Enable	19	0b	Enables bit for AcpiGpe0Blk, offset 00, bit [19] GPM0Status
GPM1Enable	20	0b	Enables bit for AcpiGpe0Blk, offset 00, bit [20] GPM1Status
GPM2Enable	21	0b	Enables bit for AcpiGpe0Blk, offset 00, bit [21] GPM2Status
GPM3Enable	22	0b	Enables bit for AcpiGpe0Blk, offset 00, bit [22] GPM3Status
GPM8Enable	23	0b	Enables bit for AcpiGpe0Blk, offset 00, bit [23] GPM8Status
Gpio0Enable	24	0b	Enables bit for AcpiGpe0Blk, offset 00, bit [24] Gpio0Status
GPM4Enable	25	0b	Enables bit for AcpiGpe0Blk, offset 00, bit [25] GPM4Status
GPM5Enable	26	0b	Enables bit for AcpiGpe0Blk, offset 00, bit [26] GPM5Status
AzaliaEnable	27	0b	Enables bit for AcpiGpe0Blk, offset 00, bit [27]; for the internal HD Audio PME
GPM6Enable	28	0b	Enables bit for AcpiGpe0Blk, offset 00, bit [28] GPM6Status
GPM7Enable	29	0b	Enables bit for AcpiGpe0Blk, offset 00, bit [29] GPM7Status
Gpio2Enable	30	0b	Enables bit for AcpiGpe0Blk, offset 00, bit [30] Gpio2Status
SataSciEnable	31	0b	Enables bit for AcpiGpe0Blk, offset 00, bit [31] SataSciStatus
This register is located at the base address defined by AcpiGpe0Blk.			

SmiCmdPort - RW - 8 bits - [SmiCmdBlk: 00h]			
Field Name	Bits	Default	Description
SmiCmdPort	7:0	00h	Used by the BIOS and the OS
This register is located at the base address defined by AcpiSmiCmd + offset 0.			

SmiCmdStatus - RW - 8 bits - [SmiCmdBlk: 01h]			
Field Name	Bits	Default	Description
SmiCmdStatus	7:0	00h	Used by the BIOS and the OS
This register is located at the base address defined by AcpiSmiCmd + offset 1.			

2.3.3.4 Power Management (PM2) Block2 Registers

The power management (PMIO2) block is resident in the PCI/LPC/ISA bridge. The PM registers are accessed via IO mapped registers xCD0h and xCD1h. The index address is first programmed into IO register xCD0h. Read or write values are accessed through IO register xCD1h.

Register Name	Offset Address
GPIO_3_to_0_Pull	E0h
GPIO_7_to_4_Pull	E1h
GPIO_11_to_8_Pull	E2h
GPIO_15_to_12_Pull	E3h
GPIO_19_to_16_Pull	E4h
GPIO_23_to_20_Pull	E5h
GPIO_27_to_24_Pull	E6h
GPIO_31_to_28_Pull	E7h
GPIO_35_to_32_Pull	E8h
GPIO_39_to_36_Pull	E9h
GPIO_43_to_40_Pull	EAh
GPIO_47_to_44_Pull	EBh
GPIO_51_to_48_Pull	ECh
GPIO_55_to_52_Pull	EDh
GPIO_59_to_56_Pull	EEh
GPIO_63_to_60_Pull	EFh
GPIO_67_to_64_Pull	F0h
GPIO_71_to_68_Pull	F1h
GPIO_75_to_72_Pull	F2h
GEvent_3_to_0_Pull	F3h
GEvent_7_to_4_Pull	F4h
GEvent_11_to_8_Pull	F5h
Gpm_3_to_0_Pull	F6h
Gpm_7_to_4_Pull	F7h
Gpm_9_to_8_Pull	F8h
Gpoc_3_to_0_Pull	F9h
DprSlpVr_Pull	FAh

GPIO_3_to_0_Pull - R - 8 bits - [PM2_Reg: E0h]			
Field Name	Bits	Default	Description
PD	3:0	1h	Pull-down enable for each of the GPIO 0: Disable 1: Enable
PU#	7:4	5h	Pull-up enable for each of the GPIO port 0: Enable 1: Disable

GPIO_7_to_4_Pull - R - 8 bits - [PM2_Reg: E1h]			
Field Name	Bits	Default	Description
PD	3:0	0h	Pull-down enable for each of the GPIO port 0: Disable 1: Enable
PU#	7:4	Fh	Pull-up enable for each of the GPIO port 0: Enable 1: Disable

GPIO_11_to_8_Pull - R – 8 bits - [PM2_Reg: E2h]			
Field Name	Bits	Default	Description
PD	3:0	8h	Pull-down enable for each of the GPIO port 0: Disable 1: Enable
PU#	7:4	Fh	Pull-up enable for each of the GPIO port 0: Enable 1: Disable

GPIO_15_to_12_Pull - R – 8 bits - [PM2_Reg: E3h]			
Field Name	Bits	Default	Description
PD	3:0	1h	Pull-down enable for each of the GPIO port 0: Disable 1: Enable
PU#	7:4	Fh	Pull-up enable for each of the GPIO port 0: Enable 1: Disable

GPIO_19_to_16_Pull - R – 8 bits - [PM2_Reg: E4h]			
Field Name	Bits	Default	Description
PD	3:0	0h	Pull-down enable for each of the GPIO port 0: Disable 1: Enable
PU#	7:4	Fh	Pull-up enable for each of the GPIO port 0: Enable 1: Disable

GPIO_23_to_20_Pull - R – 8 bits - [PM2_Reg: E5h]			
Field Name	Bits	Default	Description
PD	3:0	0h	Pull-down enable for each of the GPIO port 0: Disable 1: Enable
PU#	7:4	Fh	Pull-up enable for each of the GPIO port 0: Enable 1: Disable

GPIO_27_to_24_Pull - R – 8 bits - [PM2_Reg: E6h]			
Field Name	Bits	Default	Description
PD	3:0	0h	Pull-down enable for each of the GPIO port 0: Disable 1: Enable
PU#	7:4	Fh	Pull-up enable for each of the GPIO port 0: Enable 1: Disable

GPIO_31_to_28_Pull - R – 8 bits - [PM2_Reg: E7h]			
Field Name	Bits	Default	Description
PD	3:0	0h	Pull-down enable for each of the GPIO port 0: Disable 1: Enable
PU#	7:4	7h	Pull-up enable for each of the GPIO port 0: Enable 1: Disable

GPIO_35_to_32_Pull - R – 8 bits - [PM2_Reg: E8h]			
Field Name	Bits	Default	Description
PD	3:0	0h	Pull-down enable for each of the GPIO port 0: Disable 1: Enable
PU#	7:4	0h	Pull-up enable for each of the GPIO port 0: Enable 1: Disable

GPIO_39_to_36_Pull - R – 8 bits - [PM2_Reg: E9h]			
Field Name	Bits	Default	Description
PD	3:0	Ch	Pull-down enable for each of the GPIO port 0: Disable 1: Enable
PU#	7:4	Eh	Pull-up enable for each of the GPIO port 0: Enable 1: Disable

GPIO_43_to_40_Pull - R – 8 bits - [PM2_Reg: EAh]			
Field Name	Bits	Default	Description
PD	3:0	Dh	Pull-down enable for each of the GPIO port 0: Disable 1: Enable
PU#	7:4	Fh	Pull-up enable for each of the GPIO port 0: Enable 1: Disable

GPIO_47_to_44_Pull - R – 8 bits - [PM2_Reg: EBh]			
Field Name	Bits	Default	Description
PD	3:0	Dh	Pull-down enable for each of the GPIO port 0: Disable 1: Enable
PU#	7:4	Fh	Pull-up enable for each of the GPIO port 0: Enable 1: Disable

GPIO_51_to_48_Pull - R – 8 bits - [PM2_Reg: ECh]			
Field Name	Bits	Default	Description
PD	3:0	0h	Pull-down enable for each of the GPIO port 0: Disable 1: Enable
PU#	7:4	Ch	Pull-up enable for each of the GPIO port 0: Enable 1: Disable

GPIO_55_to_52_Pull - R – 8 bits - [PM2_Reg: EDh]			
Field Name	Bits	Default	Description
PD	3:0	0h	Pull-down enable for each of the GPIO port 0: Disable 1: Enable
PU#	7:4	Fh	Pull-up enable for each of the GPIO port 0: Enable 1: Disable

GPIO_69_to_56_Pull - R – 8 bits - [PM2_Reg: EEh]			
Field Name	Bits	Default	Description
PD	3:0	0h	Pull-down enable for each of the GPIO port 0: Disable 1: Enable
PU#	7:4	Fh	Pull -up enable for each of the GPIO port 0: Enable 1: Disable

GPIO_63_to_60_Pull - R – 8 bits - [PM2_Reg: EFh]			
Field Name	Bits	Default	Description
PD	3:0	0h	Pull-down enable for each of the GPIO port 0: Disable 1: Enable
PU#	7:4	Fh	Pull-up enable for each of the GPIO port 0: Enable 1: Disable

GPIO_67_to_64_Pull - R – 8 bits - [PM2_Reg: F0h]			
Field Name	Bits	Default	Description
PD	3:0	0h	Pull-down enable for each of the GPIO port 0: Disable 1: Enable
PU#	7:4	Bh	Pull-up enable for each of the GPIO port 0: Enable 1: Disable

GPIO_71_to_68_Pull - R – 8 bits - [PM2_Reg: F1h]			
Field Name	Bits	Default	Description
PD	3:0	0h	Pull-down enable for each of the GPIO port 0: Disable 1: Enable
PU#	7:4	0h	Pull-up enable for each of the GPIO port 0: Enable 1: Disable

GPIO_75_to_72_Pull - R – 8 bits - [PM2_Reg: F2h]			
Field Name	Bits	Default	Description
PD	1:0	00b	Pull-down enable for each of the GPIO port 0: Disable 1: Enable
Reserved	3:2		
PU#	5:4	11b	Pull-up enable for each of the GPIO port 0: Enable 1: Disable
Reserved	7:6		

GEvent_3_to_0_Pull - R – 8 bits - [PM2_Reg: F3h]			
Field Name	Bits	Default	Description
PD	3:0	0h	Pull-down enable for each of the GEvent port 0: Disable 1: Enable
PU#	7:4	0h	Pull-up enable for each of the GEvent port 0: Enable 1: Disable

GEvent_7_to_4_Pull - R – 8 bits - [PM2_Reg: F4h]			
Field Name	Bits	Default	Description
PD	3:0	0h	Pull-down enable for each of the GEvent port 0: Disable 1: Enable
PU#	7:4	0h	Pull-up enable for each of the GEvent port 0: Enable 1: Disable

GEvent_11_to_8_Pull - R – 8 bits - [PM2_Reg: F5h]			
Field Name	Bits	Default	Description
PD	0	0b	Pull-down enable for each of the GEvent[8] port 0: Disable 1: Enable
PD	1	0b	Pull-down enable for each of the ExtEvent[0] port 0: Disable 1: Enable
PD	2	0b	Pull-down enable for each of the ExtEvent[1] port 0: Disable 1: Enable
Reserved	3		
PU#	4	0b	Pull-up enable for each of the GEvent[8] port 0: Enable 1: Disable
PU#	5	0b	Pull-up enable for each of the ExtEvent[0] port 0: Enable 1: Disable
PU#	6	0b	Pull-up enable for each of the ExtEvent[1] port 0: Enable 1: Disable
Reserved	7		

Gpm_3_to_0_Pull - R – 8 bits - [PM2_Reg: F6h]			
Field Name	Bits	Default	Description
PD	3:0	0h	Pull-down enable for each of the Gpm port 0: Disable 1: Enable
PU#	7:4	0h	Pull-up enable for each of the Gpm port 0: Enable 1: Disable

Gpm_7_to_4_Pull - R – 8 bits - [PM2_Reg: F7h]			
Field Name	Bits	Default	Description
PD	3:0	0h	Pull-down enable for each of the Gpm port 0: Disable 1: Enable
PU#	7:4	2h	Pull-up enable for each of the Gpm port 0: Enable 1: Disable

Gpm_9_to_8_Pull - R – 8 bits - [PM2_Reg: F8h]			
Field Name	Bits	Default	Description
PD	1:0	10b	Pull-down enable for each of the Gpm port (GPM8 – bit [0]; GPM9 – bit [1]) 0: Disable 1: Enable
Reserved	3:2		

Gpm_9_to_8_Pull - R – 8 bits - [PM2_Reg: F8h]			
Field Name	Bits	Default	Description
PU#	5:4	10b	Pull-up enable for each of the Gpm port (GPM8 – bit [4]; GPM9 – bit [5]) 0: Enable 1: Disable
Reserved	7:6		

Gpoc_3_to_0_Pull - R – 8 bits - [PM2_Reg: F9h]			
Field Name	Bits	Default	Description
PD	3:0	0h	Pull-down enable for each of the Gpoc port 0: Disable 1: Enable
PU#	7:4	Fh	Pull-up enable for each of the Gpoc port 0: Enable 1: Disable

2.3.4 WatchDogTimer Registers

WatchDogTimer base address is defined in PM_Reg 6F:6Ch.

Register Name	Offset Address
WatchDogControl	00h
WatchDogCount	04h

WatchDogControl - RW - 32 bits - [WD_Mem_Reg: 00h]			
Field Name	Bits	Default	Description
WatchDogRunStopB	0	0b	This bit is used to control or indicate whether the watchdog is in the Running and Stopped states. 1: Watchdog is in the Running state 0: Watchdog is in the Stopped state If the watchdog is in the Stopped state and a 1 is written to bit [0], the watchdog moves to the Running state, but a count interval is not started until a 1 is written to bit [7]. If the watchdog is in the Running state, writing a 1 to bit 0 has no effect. The bit is only valid when the watchdog is enabled.
WatchDogFired	1	0b	A value of "1" indicates that the watchdog timer has expired and caused the current restart. The bit is cleared by writing a "1" to bit 1 in the Watchdog Control register. Writing a "0" has no effect. The bit is cleared by a power cycle or by the operating system and it must remain cleared for any restart that is not caused by the watchdog timer firing. The bit is only valid when the watchdog is enabled.
WatchDogAction	2	0b	This bit determines the action to be taken when the watchdog timer expires. 0: System reset 1: System power off The bit is only valid when the watchdog is enabled.
WatchDogDisable	3	Same as PM IO x69, bit 0	This bit reflects the state of the watchdog timer hardware. 0: Enable 1: Disable
Reserved	6:4		
WatchDogTrigger (WO)	7	0b	Write only. Setting this bit triggers the watchdog to start a new count interval, counting down from the value that was last written to the Watchdog Count Register. This bit is always read as zero. Setting this bit has no effect if the watchdog is disabled or stopped.
Reserved	31:8		

WatchDogCount - RW - 32 bits - [WD_Mem_Reg: 04h]			
Field Name	Bits	Default	Description
WatchDogCount	15:0	----	This defines the countdown time for the counter. The units are defined in the Units field in the Watchdog Resource Table (WDRT). The maximum value is defined in the Max Count field in the WDRT. Reading this register returns in the current counter value.
Reserved	31:16		

2.3.5 ASF SMBus Host Interface Registers

The ASF SMBus host register block is resident in the IO space whose base is defined at offset 58h/59h of config space.

Note: ASF is not supported by the SP5100; however, the SMBUS1 controller can be used as a generic SMBUS interface

with SMBUS1 controller operating as master to communicate to SMBUS slave devices that need to be on S5 power domain. Some of the ASF registers are used to initialize the controller in the master mode.

Register Name	Offset Address
HostStatus	00h
HostControl	02h
HostCommand	03h
SlaveAddress	04h
Data0	05h
Data1	06h
Data	07h
PEC	08h
ListenAdr	09h
ASFStatus	0Ah
StatusMask0	0Bh
StatusMask1	0Ch
SlaveControl	0Dh
RemoteCtrlAdr	0Eh
DataReadPointer	10h
DataWritePointer	11h
SetDatareadpointer	12h
DataBankSel	13h

HostStatus – R - 8 bits - [ASF_IO: 00h]			
Field Name	Bits	Default	Description
HostBusy	0	0b	0: SM bus Host is idle 1: SM bus Host is busy
INTR	1	0b	The bit is set by termination of a command and can be cleared by writing to 1.
DevError	2	0b	0: Slave device behave correctly 1: No ACK or Slave device responses incorrectly
BusCollision	3	0b	0: No bus collision 1: Bus collision
PECError	4	0b	0: No CRC error 1: CRC error happens
Reserve	6:5	00b	
LastByte	7	0b	0: Last byte has not received 1: Last byte has received

HostControl – RW - 8 bits - [ASF_IO: 02h]			
Field Name	Bits	Default	Description
Reserved	0	0b	
KillHost	1	0b	0: Enable SM master 1: Reset SM master
Protocol	4:2	000b	000: Quick 001: Byte 010: Byte Data 011: Word Data 100: Process call 101: Block 110: Block write-Block read-process call
PECAppend	5	0b	0: No PEC append 1: Automatic PEC append. ASF HC caculates CRC code and append to the tail of the data packets.
Start	6	0b	WO: 0: Always read 0 on reads 1: Writing 1 to initiate the command

HostControl – RW - 8 bits - [ASF_IO: 02h]			
Field Name	Bits	Default	Description
PECEnable	7	0b	0: PEC disable 1: PEC enable, enable CRC checking when ASF HC presents as SM master and SM slave.

HostCommand – RW - 8 bits - [ASF_IO: 03h]			
Field Name	Bits	Default	Description
HostCommand	7:0	00h	Command to be transmitted by master

SlaveAddress– RW - 8 bits - [ASF_IO: 04h]			
Field Name	Bits	Default	Description
RW	0	0b	0: Write 1: Read
Address	7:1	00h	Provide the SM address of Slave

Data0– RW - 8 bits - [ASF_IO: 05h]			
Field Name	Bits	Default	Description
Data0	7:0	00h	It has a different meaning in different conditions. 1: Contains count to indicate how many bytes to be sent (not including PEC byte) in block write and block write-Block read-process call. 2: Contains count to indicate how many bytes have been received in block read and block write-Block read-process call. 3: First byte of Data bytes in Byte/Word write and process Call or first byte received in Byte/Word read.

Data1– RW - 8 bits - [ASF_IO: 06h]			
Field Name	Bits	Default	Description
Data1	7:0	00h	The second byte of Data bytes in Word write and process Call or second byte received in Word read

DataIndex– RW - 8 bits - [ASF_IO: 07h]			
Field Name	Bits	Default	Description
DataIndex	7:0	00h	It is mapped to 72 Data registers in Data buffer for in block write/read and block write-Block read-process call..

PEC– RW - 8 bits - [ASF_IO: 08h]			
Field Name	Bits	Default	Description
PEC	7:0	00h	PEC byte to be sent to slave.

ListenAdr– RW - 8 bits - [ASF_IO: 09h]			
Field Name	Bits	Default	Description
ListenAdrEn	0	0	.1: Enable ListenMode when the slave address equals to ListenAdr[7:1] 0: Disable ListenMode when the slave address equals to ListenAdr[7:1]
ListenAdr	7:1	00h	.The slave address which ASF slave response as ListenMode.

ASFStatus– RW - 8 bits - [ASF_IO: 0Ah]			
Field Name	Bits	Default	Description
ResetRemotePowerUp Status	7	0b	1: Reset the RemotePowerUp status bit in this register. Sw has to wait until RemotePowerUp status bit is cleared to make sure that the status bit does cleared. 0: Enable RemotePowerUp status bit in this register
ResetSlaveIntr	6	0b	1: Reset the SlaveIntr status bit in this register. 0: Enable SlaveIntr bit in this register
SlaveIntr	5	0b	ASF Slave interrupt Status, can be cleared to 0 by bit7 of this register.
TmrOutEn	4	0b	Set to 1 to enable SMBus time out checking.
RemotePowerCycle	3	0b	1: Power cycle has been triggered by ASF 0: No Power cycle ASF event Writing 1 can clear it.
RemotePowerUp	2	0b	1: Power up has been triggered by ASF 0: No Power up ASF event Can be cleared to 0 by Writing 1 to ResetRemotePowerUpStatus bit in this register.
RemotePowerDown	1	0b	1: Power down has been triggered by ASF 0: No Power down ASF event Writing 1 can clear it.
RemoteReset	0	0b	1: Reset has been triggered by ASF 0: No Reset cycle ASF event Writing 1 can clear it.

StatusMask0– RW - 8 bits - [ASF_IO: 0Bh]			
Field Name	Bits	Default	Description
Temp0StatusEnable	0	0b	1: Report Temp0 status to ASF 0: No report
Temp1StatusEnable	1	0b	1: Report Temp1 status to ASF 0: No report
Temp2StatusEnable	2	0b	1: Report Temp2 status to ASF 0: No report
Temp3StatusEnable	3	0b	1: Report Temp3 status to ASF 0: No report
AMDSIStatusEnable	4	0b	1: Report AMDSI status to ASF 0: No report
FanSpeed0StatusEnable	5	0b	1: Report Fan0 Speed Status to ASF 0: No report
FanSpeed1StatusEnable	6	0b	1: Report Fan1 Speed Status to ASF 0: No report
FanSpeed2StatusEnable	7	0b	1: Report Fan2 Speed Status to ASF 0: No report

StatusMask1– RW - 8 bits - [ASF_IO: 0Ch]			
Field Name	Bits	Default	Description
AnalogIo0StatusEnable	0	0b	1: Report AnalogIo0 status to ASF 0: No report
AnalogIo1StatusEnable	1	0b	1: Report AnalogIo1 status to ASF 0: No report
AnalogIo2StatusEnable	2	0b	1: Report AnalogIo2 status to ASF 0: No report
AnalogIo3StatusEnable	3	0b	1: Report AnalogIo3 status to ASF 0: No report
AnalogIo4StatusEnable	4	0b	1: Report AnalogIo4 status to ASF 0: No report
AnalogIo5StatusEnable	5	0b	1: Report AnalogIo5 status to ASF 0: No report

StatusMask1– RW - 8 bits - [ASF_IO: 0Ch]			
Field Name	Bits	Default	Description
AnalogIo6StatusEnable	6	0b	1: Report AnalogIo6 status to ASF 0: No report
AnalogIo7StatusEnable	7	0b	1: Report AnalogIo7 status to ASF 0: No report

SlaveMisc- RW - 8 bits - [ASF_IO: 0Dh]			
Field Name	Bits	Default	Description
SlavePECErrror	0	0b	RO 0: No PEC error 1: PEC error
SlaveBusCollision	1	0b	RO 0: No BusCollision 1: BusCollision happens
SlaveDevError	2	0b	RO 0: Expected reponse 1: Unexpected reponse
WrongSP	3	0b	RO 0: No SP error 1: No SP when turn to read
IntruderAlertStsEn	4	0b	RW: 0: FanSpeed2Status is returned 1: IntruderAlertSts is returned
SuspendSlave	5	0b	RW Write 1 to Suspend (stop) ASF Slave state machine
KillSlave	6	0b	RW Write 1 to reset Slave ASF Slave state machine
LegacySensorEn	7	0b	RW 0: Disable Legacy Sensor 1: Enable Legacy Sensor

RemoteCtrlAdr– RW - 8 bits - [ASF_IO: 0Eh]			
Field Name	Bits	Default	Description
Reserved	0	0b	
RemoteCtrlAdr	7:1	00h	SM address of Remote Control device.

SensorAdr– RW - 8 bits - [ASF_IO: 0Fh]			
Field Name	Bits	Default	Description
Reserved	0	0b	
SensorAdr	7:1	00h	SM address of Sensor.

The SP5100 is hardcoded to recognize the following ASF commands. BIOS should report these values accordingly in the ASF table if the system supports ASF function.

	Control command	Control data value
Reset	00h	00h
PowerUp	01h	00h
PowerDown	02h	00h
PowerCycle	03h	00h
SensorPolling	23h	00h

DataReadPointer– R - 8 bits - [ASF_IO: 10h]			
Field Name	Bits	Default	Description
DataReadPointer	7:0	00h	Current read pointer to the value specified in this register

DataWritePointer– R - 8 bits - [ASF_IO: 11h]			
Field Name	Bits	Default	Description
DataWritePointer	7:0	00h	Show current write pointer to the value specified in this register

SetDataReadPointer– RW - 8 bits - [ASF_IO: 12h]			
Field Name	Bits	Default	Description
SetDataReadPointer	7:0	00h	Forces the current write pointer to the value specified in this register

DataBankSel– RW - 8 bits - [ASF_IO: 13h]			
Field Name	Bits	Default	Description
DataBank	1:0	0	Read Only. Bit [0]: 0 means that Data Bank is the latest touched data bank, 1 means that Data bank 0 is the latest touched data bank. Bit [1]: 1 means that all of Data Bank now are full, otherwise still have the space.
DataBank_Full	2	0	Value 1 means that Data Bank is full; otherwise it is free to use. Writing to 1 clear status
DataBank0_Full	3	0	Value 1 means that Data Bank 0 is full; otherwise it is free to use. Writing to 1 clear status
Slavebusy	6	0	Busy status of ASF Slave. Read only.
SetReadDataBank	7	0	Set to 0 to select Data bank and 1 to select to Data Bank 0.

Semaphore - RW - 4 bits - [ASF_IO:14h]			
Field Name	Bits	Default	Description
HostSemaphore	0	0b	Bits [0] and [2] are meant to be used as software semaphore between the host and the integrated micro-controller (IMC). When both host and IMC want to use the same resource, they can write to these semaphore bits first, then followed by a read. If the read returns a 1 in the semaphore bit, it means it has established the semaphore first. Write 1 to set this bit. This bit can only be set when ImcSemaphore is cleared. Writing 0 has no effect. Read returns the value of this bit.
ClrHostSemaphore	1	0b	Write 1 to clear HostSemaphore bit. Write 0 has no effect and read always returns 0
ImcSemaphore	2	0b	Write 1 to set this bit. This bit can only be set when HostSemaphore is clear. Writing 0 has no effect. Read returns the value of this bit
ClrImcSemaphore	3	0b	Write 1 to clear ImcSemaphore bit. Writing 0 has no effect and read always returns 0

Defines 23h as Legacy sensor polling command

Remote control action definition:

	control command	control data value
Reset	00h	00h

PowerUp	01h	00h
PowerDown	02h	00h
PowerCycle	03h	00h

2.3.6 RTC Extended Registers

The RTC extended register block is accessible through PM_Reg: 7E/7F Index/Data port.

Register Name	Offset Address
DltSavEnable	00h
SprFwdCtrl	01h
SprFwdMonth	02h
FallBackCtrl	03h
FallBackMonth	04h

DltSavEnable – RW – 8 bits – [RtcExt_Reg: 00h]			
Field Name	Bits	Default	Description
DltSavEnable	0	0b	Set to 1 to enable RTC daylight saving feature.
Reserved	7:6		
DltSavEnable register			

SprFwdCtrl – RW – 8 bits – [RtcExt_Reg: 01h]			
Field Name	Bits	Default	Description
SprFwdHour	5:0	00h	This BCD value determines which hour (24 hour mode) to do the “spring forward”. Setting of 02h means 2am. Default is 00h which also denotes 2am. Spring forward is usually 2am in United States and 1am in Europe.
SprFwdWeek	6	0b	This value determines which Sunday morning to do the “spring forward”. Default is 0 which denotes the 1 st week. Setting of 1 means the last week of the month. Spring forward is usually at the 1 st Sunday of April in United States and last Sunday of March in Europe.
Reserved	7		
SprFwdCtrl register			

SprFwdMonth – RW – 8 bits – [RtcExt_Reg: 02h]			
Field Name	Bits	Default	Description
SprFwdMonth	4:0	00h	This BCD value determines which month to “spring forward”. Setting of 04h means April. Default is 00h which also denotes April. Spring forward is usually at April in United States and March in Europe.
Reserved	7:5		
SprFwdMonth register			

FallBackCtrl – RW – 8 bits – [RtcExt_Reg: 03h]			
Field Name	Bits	Default	Description
FallBackHour	5:0	00h	This BCD value determines which hour (24 hour mode) to do the “fall back”. Setting of 02h means 2am. Default is 00h which also denotes 2am. Fall back is usually 2am in United States and 1am in Europe.

FallBackCtrl – RW – 8 bits – [RtcExt_Reg: 03h]			
Field Name	Bits	Default	Description
FallBackWeek	6	0b	This value determines which Sunday morning to do the “fall back”. Default is 0 which denotes the last week. Setting of 1 means the first week of the month. Fall back is usually at the last Sunday of October in both United States and Europe.
Reserved	7		
FallBackCtrl register			

FallBackMonth – RW – 8 bits – [RtcExt_Reg: 04h]			
Field Name	Bits	Default	Description
FallBackMonth	4:0	00h	This BCD value determines which month to “fall back”. Setting of 10h means October. Default is 00h which also denotes October. Fall back is usually at October in both United States and Europe.
Reserved	7:5		
FallBackMonth register			

Week Timer registers

The 16-bit Week Timer is a battery powered down counter timer that supports 1ms, 1 second and 1minute resolution and auto reloads when the timer reaches 0. The WEEK_ALARM interrupt is asserted when the timer reaches 0 and stays asserted until the timer is disabled. The Week Timer registers are located in RTC extended register block index 10h through 14h.

WeekTimerControl – RW – 8 bits – [RtcExt_Reg: 10h]			
Field Name	Bits	Default	Description
Enable	0	0b	This bit is used to start and stop the Week Timer. 0: Disable 1: Enable
Resolution	2:1	00b	These bits are used to control the resolution of the Week Timer counter. 00: 1 minute 01: 1 second 10: 1ms 11: Reserved
Reserved	7:3		
WeekTimerControl register Note: The Enable should be cleared when changing the Resolution setting.			

WeekTimerReloadLow – RW – 8 bits – [RtcExt_Reg: 11h]			
Field Name	Bits	Default	Description
WeekTimerReloadLow	7:0		This register is used to program the lower 8 bits of the 16-bit WeekTimerReload register. Writing the WeekTimerReloadLow register causes the 16-bit WeekTimerReload to be written into the Week Timer.
WeekTimerReloadLow register Note: The Enable in the WeekTimerControl register should be cleared before performing a write access to the WeekTimerReloadLow or WeekTimerReload High register.			

WeekTimerReloadHigh – RW – 8 bits – [RtcExt_Reg: 12h]			
Field Name	Bits	Default	Description
WeekTimerReloadHigh	7:0		This register is used to program the upper 8 bits of the 16-bit WeekTimerReload register. This register should be programmed before writing the WeekTimerReloadLow register.
WeekTimerReloadHigh register Note: The Enable in the WeekTimerControl register should be cleared before performing a write access to the WeekTimerReloadLow or WeekTimerReload High register.			

WeekTimerDataLow – R – 8 bits – [RtcExt_Reg: 13h]			
Field Name	Bits	Default	Description
WeekTimerDataLow	7:0		This register is used to read the current state of the 16-bit Week Timer. Reading from the WeekTimerDataLow register returns the lower 8 bits of the 16-bit Week Timer and cause the upper 8 bits to be latched into the WeekTimerDataHigh register.
WeekTimerDataLow register Note: Two reads are required to read the current state of the 16-bit Week Timer: the first read from the WeekTimerDataLow register returns the lower 8 bits of the 16-bit Week Timer and the second read from the WeekTimerDataHigh register return the upper 8 bits of the 16-bit Week Timer.			

WeekTimerDataHigh – R – 8 bits – [RtcExt_Reg: 14h]			
Field Name	Bits	Default	Description
WeekTimerDataHigh	7:0		This register is used to read the current state of the 16-bit Week Timer. Reading from the WeekTimerDataHigh register returns the upper 8 bits of the 16-bit Week Timer latched by a previous read from the WeekTimerDataLow register.
WeekTimerDataLow register Note: Two reads are required to read the current state of the 16-bit Week Timer: the first read from the WeekTimerDataLow register returns the lower 8 bits of the 16-bit Week Timer and the second read from the WeekTimerDataHigh register return the upper 8 bits of the 16-bit Week Timer.			

2.4 IDE Controller (Device 20, Function 1)

IDE controller registers are supported in PCI configuration and I/O space. These registers are cleared by the PCIRST# signal; therefore, they will be cleared on a warm boot.

2.4.1 PCI Configuration Registers

Register Name	Offset Address
Vendor ID	00h
Device ID	02h
Command	04h
Status	06h
Revision ID/Class Code	08h
Cache Link Size	0Ch
Master Latency Timer	0Dh
Header Type	0Eh
BIST Mode Type	0Fh
Base Address 0	10h
Base Address 1	14h
Base Address 2	18h
Base Address 3	1Ch
Bus Master Interface Base Address	20h
Subsystem ID and Subsystem Vendor ID	2Ch
Capabilities Pointer	34h
Interrupt Line	3Ch
Interrupt Pin	3Dh
Min_gnt	3Eh
Max_latency	3Fh
IDE PIO Timing	40h
IDE Legacy DMA (Multi-words DMA) Timing Modes	44h
IDE PIO	48h
IDE PIO Mode	4Ah
IDE Status	4Ch
IDE Ultra DMA Control	54h
IDE Ultra DMA Status	55h
IDE Ultra DMA Mode	56h
IDE PCI Retry Timing Counter	60h
PCI Error Control	61h
IDE Internal Control	62h
IDE PLL Control	64h
IDE MSI Programmable Weight	68h
IDE Dynamic Clocking	6Ch
IDE MSI Control	70h
IDE MSI Address Register	74h
IDE MSI Data Register	78h
IDE IDP Address Register	7Ah
IDE IDP Data Register	7Ch

Vendor ID - R - 16 bits - [PCI_Reg:00h]			
Field Name	Bits	Default	Description
Vendor ID	15:0	1002h	This register holds a unique 16-bit value assigned to a vendor, and combined with the device ID, it identifies any PCI device.
Vendor ID Register: This register holds a unique 16-bit value assigned to a vendor, and combined with the device ID it identifies any PCI device.			

Device ID - R - 16 bits - [PCI_Reg:02h]			
Field Name	Bits	Default	Description
Device ID	15:0	439Ch	This register holds a unique 16-bit value assigned to a device, and combined with the vendor ID it, identifies any PCI device.
Device ID Register: This register holds a unique 16-bit value assigned to a device, and combined with the vendor ID it identifies any PCI device.			

Command – RW – 16 bits – [PCI_Reg:04h]			
Field Name	Bits	Default	Description
I/O Access Enable	0	0b	I/O Access Enable. This bit controls access to the I/O space registers. When this bit is 1, it enables access to Legacy IDE ports, and PCI bus master IDE I/O registers are enabled.
Memory Access Enable	1	0b	Memory Access Enable. This function is not implemented. This bit is always 0.
Bus Master Enable	2	0b	Master Enable. Bus master function enable. 1=enable, 0=disable.
Special Cycle Recognition Enable	3	0b	Special Cycle recognition enable. This feature is not implemented and this bit is always 0.
Memory Write and Invalidate Enable	4	0b	Memory Write and Invalidate Enable.
VGA Palette Snoop Enable	5	0b	VGA Palette Snoop Enable- The IDE host controller does not need to snoop VGA palette cycles. This bit is always 0.
PERR- Detection Enable	6	0b	PERR- (Response) Detection Enable bit – If set to 1, the IDE host controller asserts PERR- when it is the agent receiving data AND it detects a parity error. PERR- is not asserted if this bit is 0. Default - 0.
Wait Cycle Enable	7	0b	Wait Cycle enable - The IDE host controller does not need to insert a wait state between the address and data on the AD lines. This bit is always 0.
SERR- Enable	8	0b	SERR- enable – If set to 1, the IDE host controller asserts SERR- when it detects an address parity error. SERR- is not asserted if this bit is 0. Default – 0.
Fast Back-to-Back Enable	9	0b	Fast Back-to-back enable. The IDE host controller only acts as a master to a single device, so this functionality is not needed. This bit is always 0.
Interrupt Disable	10	0b	Interrupt disable bit (complies to PCI 2.3 spec.)
Reserved	15:11	00h	Reserved. Always wired as 0's.
Command Register: The PCI specification defines this register to control a PCI device's ability to generate and respond to PCI cycles.			

Status – RW – 16 bits – [PCI_Reg:06h]			
Field Name	Bits	Default	Description
Reserved	2:0	0b	Reserved. These bits are always read as 0.
Interrupt Status	3	0b	Interrupt status bit. It complies with the PCI 2.3 specification.
Capabilities List	4	1b	This bit is hardwired to 1 to indicate that the Capabilities Pointer is located at 34h.
66MHz Support	5	1b	66MHz capable. This feature is supported in the IDE host controller.
UDF Supported	6	0b	UDF Supported. This feature is not implemented and this bit is always 0.
Fast Back-to-Back Capable	7	0b	Fast Back-to-Back Capable. This feature is not implemented and this bit is always 0.
Data Parity Error	8	0b	Data Parity reported. Set to 1 if the IDE host controller detects PERR- asserted while acting as PCI master (whether PERR- was driven by IDE host controller or not.)

Status – RW – 16 bits – [PCI_Reg:06h]			
Field Name	Bits	Default	Description
DEVSEL- Timing	10:9	01b	DEVSEL- timing. Read only bits indicating DEVSEL- timing when performing a positive decode. Since DEVSEL- is asserted to meet the medium timing, these bits are encoded as 01b.
Signaled Target Abort	11	0b	Signaled Target Abort. This bit is set to 1, when the IDE host controller signals Target Abort.
Received Target Abort	12	0b	Received Target Abort. This bit is set to 1 when the IDE host controller-generated PCI cycle (IDE host controller is the PCI master) is aborted by a PCI target. Cleared by writing a 1 to it.
Received Master Abort Status	13	0b	Received Master Abort Status. Set to 1 when the IDE host controller acting as a PCI master, aborts a PCI bus memory cycle. Cleared by writing a 1 to this bit. 0: Default
SERR- Status	14	0b	SERR- status. This bit is set to 1 when the IDE host controller detects a PCI address parity error.
Detected Parity Error	15	0b	Detected Parity Error. This bit is set to 1 when the IDE host controller detects a parity error.
Status Register: The PCI specification defines this register to record status information for PCI related events. This is a read/write register. However, writes can only reset bits. A bit is reset when the register is written and the data in the corresponding bit location is a 1.			

Revision ID/Class Code- RW – 32 bits – [PCI_Reg:08h]			
Field Name	Bits	Default	Description
Revision ID	7:0	00h	These bits are hardwired to 00h to indicate the revision level of the chip design (for the SP5100).
IDE Host Controller Operating Mode Selection	15:8	8Ah	Programmable I/F. These 8 bits are read/write. Bit [7]: Master IDE Device. Always 1. Bits [6:4]: Reserved. Always read as 0's. Bit [3]: Secondary IDE Enable bit. Setting this bit with PCI configuration offset 0x49 bit 8 back to back will disable secondary IDE host controller. Bit [2]: Operating Mode for Secondary. 1: Native PCI-mode. 0: Compatibility Mode(Default). Bit [1]: Primary IDE Enable bit. Setting this bit with PCI configuration offset 0x49 bit [0] back to back will disable primary IDE host controller. Bit [0]: Operating Mode for Primary. 1: Native PCI-mode. 0: Compatibility mode (Default).
Sub-Class Code	23:16	01h	Sub-Class Code. These 8 bits are read only and wired to 01h to indicate an IDE Controller.
Class Code	31:24	01h	Class Code. These 8 bits are read only and wired to 01h to indicate a Mass-Storage Controller.
Revision ID/Class Code Register: This register contains the device's revision information, generic function of a device, and the specific register level programming interface. The Base class is 01h (Mass-Storage Controller), Sub-class is 01h (IDE Controller).			

Cache Link Size – RW – 8 bits – [PCI_Reg:0Ch]			
Field Name	Bits	Default	Description
Cache Link Size Register	7:0	00h	If the value is 10 that means the cache line size is 16 DW (64 byte).
Cache Line Size Register: This register specifies cache line size and the default value is 00.			

Master Latency Timer – RW – 8 bits – [PCI_Reg:0Dh]			
Field Name	Bits	Default	Description
Reserved	2:0	0h	They are not used and are hardwired to 0.
Master Latency Timer	7:3	00h	Master Latency Timer. This number represents the guaranteed time slice allotted to IDE host controller for burst transactions.
Master Latency Timer: This register specifies the value of Latency Timer in units of PCICLKs.			

Header Type – R – 8 bits – [PCI_Reg:0Eh]			
Field Name	Bits	Default	Description
Header Type	7:0	00h	Header Type. Since the IDE host controller is a single-function device, this register contains a value of 00h.
Header Type Register: This register identifies the IDE controller module as a single function device.			

BIST Mode Type – R – 8 bits – [PCI_Reg:0Fh]			
Field Name	Bits	Default	Description
Built-in-Self Test Mode	7:0	00h	Built-in-Self Test modes. Since the IDE host controller does not support BIST modes, this register is always read as 00.
BIST Mode Type Register: This register is used for control and status for Built-in-Self test. The IDE host controller has no BIST modes			

Base Address 0 – RW – 32 bits – [PCI_Reg:10h]			
Field Name	Bits	Default	Description
Resource Type Indicator	0	1b	RTE (Resource Type Indicator). This bit is wired to 1 to indicate that the base address field in this register maps to I/O space.
Reserved	2:1	00b	Reserved. Always read as 0's.
Primary IDE CS0 Base Address	15:3	0000h	Base Address for Primary IDE Bus CS0. This register is used for native mode only. Base Address 0 is not used in compatibility mode.
Reserved	31:16	0000h	Reserved. Always read as 0's.
Base Address 0 Register (Primary CS0): This register identifies the base address of a contiguous memory space in main memory. When combined mode is enabled, the Base address is either used by IDE (ChannelSel ==1) or the SATA controller (port 4/5) (ChannelSel ==0). ChannelSel is bit 4 in SMBUS/ACPI PCI configuration space offset 0xAD.			

Base Address 1 – RW – 32 bits – [PCI_Reg:14h]			
Field Name	Bits	Default	Description
Resource Type Indicator	0	1b	RTE (Resource Type Indicator). This bit is wired to 1 to indicate that the base address field in this register maps to I/O space.
Reserved	1	0b	Reserved. Always read as 0's.
Primary IDE CS1 Base Address	15:2	0000h	Base Address for Primary IDE Bus CS1. This register is used for native mode only. Base Address 1 is not used in compatibility mode.
Reserved	31:16	0000h	Reserved. Always read as 0's.
Base Address 1 Register (Primary CS1): This register identifies the base address of a contiguous memory space in main memory. When combined mode is enabled, the Base address is either used by IDE (ChannelSel ==1) or SATA controller (port 4/5) (ChannelSel ==0). ChannelSel is bit 4 in SMBUS/ACPI PCI configuration space offset 0xAD.			

Base Address 2 – RW – 32 bits – [PCI_Reg:18h]			
Field Name	Bits	Default	Description
Resource Type Indicator	0	1b	RTE (Resource Type Indicator). This bit is wired to 1 to indicate that the base address field in this register maps to I/O space.
Reserved	2:1	00b	Reserved. Always read as 0's.
Secondary IDE CS0 Base Address	15:3	0000h	Base Address for Secondary IDE Bus CS0. This register is used for native mode only. Base Address 2 is not used in compatibility mode.
Reserved	31:16	0000h	Reserved. Always read as 0's.
Base Address 2 Register (Secondary CS0): This register identifies the base address of a contiguous memory space in main memory. When combined mode is enabled, the Base address is either used by IDE (ChannelSel ==1) or SATA controller (port 4/5) (ChannelSel ==0). ChannelSel is bit 4 in SMBUS/ACPI PCI configuration space offset 0xAD.			

Base Address 3 – RW – 32 bits – [PCI_Reg:1Ch]			
Field Name	Bits	Default	Description
Resource Type Indicator	0	1b	RTE (Resource Type Indicator). This bit is wired to 1 to indicate that the base address field in this register maps to I/O space.
Reserved	1	0b	Reserved. Always read as 0's.
Secondary IDE CS1 Base Address	15:2	0000h	Base Address for Secondary IDE Bus CS1. This register is used for native mode only. Base Address 3 is not used in compatibility mode.
Reserved	31:16	0000h	Reserved. Always read as 0's.
Base Address 3 Register (Secondary CS1): This register identifies the base address of a contiguous memory space in main memory. When combined mode is enabled, the Base address is either used by IDE (ChannelSel ==1) or SATA controller (port 4/5) (ChannelSel ==0). ChannelSel is bit 4 in SMBUS/ACPI PCI configuration space offset 0xAD.			

Bus Master Interface Base Address – RW – 32 bits – [PCI_Reg:20h]			
Field Name	Bits	Default	Description
Resource Type Indicator	0	1b	RTE (Resource Type Indicator). This bit is wired to 1 to indicate that the base address field in this register maps to I/O space.
Reserved	3:1	0h	Reserved. Always read as 0's.
Bus Master Interface Register Base Address	15:4	000h	Base Address for Bus Master interface registers and correspond to AD[15:4].
Reserved	31:16	0000h	Reserved. Always read as 0's.
Bus Master Interface Base Address Register: This register selects the base address of a 16-byte I/O space interface for bus-master functions.			

Subsystem ID and Subsystem Vendor ID – RW – 32 bits – [PCI_Reg:2Ch]			
Field Name	Bits	Default	Description
Subsystem Vendor ID	15:0	0000h	Subsystem Vendor ID
Subsystem ID	31:16	0000h	Subsystem ID
Subsystem ID and Subsystem Vendor ID: This subsystem ID and subsystem Vendor ID register is write once and read only.			

MSI Capabilities Pointer – R – 8 bits – [PCI_Reg:34h]			
Field Name	Bits	Default	Description
Capabilities Pointer	7:0	70h	The first pointer of Capability block
MSI Capabilities Pointer Register: This register will show the pci 239nstante239tion register starting address and it is read only.			

Interrupt Line – RW – 8 bits – [PCI_Reg:3Ch]			
Field Name	Bits	Default	Description
Interrupt Line	7:0	00h	Identifies which input on the interrupt controller the function's PCI interrupt request pin (as specified in its Interrupt Pin register) is routed to
Interrupt Line Register: This register identifies which of the system interrupt controllers the device interrupt pin is connected to. The value of this register is used by device drivers.			

Interrupt Pin – R – 8 bits – [PCI_Reg:3Dh]			
Field Name	Bits	Default	Description
Interrupt Pin	7:0	01h	Hardwired to 01h.
Interrupt Pin Register: This register identifies the interrupt pin a device uses. Since the IDE host controller uses IRQ14, this value is supposed to be 00. However, the IDE controller will generate the PCI interrupt INTA# signal on the PCI bus. Therefore, this pin register is set to 01h.			

Min_gnt – R – 8 bits – [PCI_Reg:3Eh]			
Field Name	Bits	Default	Description
Minimum Grant	7:0	00h	Hardwired to 0's and always read as 0's.
Min_gnt Register: This register specifies the desired settings for how long of a burst the IDE host controller needs assuming a clock rate of 33MHz. The value specifies a period of time in units of ¼ microseconds.			

Max_latency – R – 8 bits – [PCI_Reg:3Fh]			
Field Name	Bits	Default	Description
Maximum Latency	7:0	00h	Hardwired to 0's and always read as 0's.
Max_latency Register: This register specifies the Maximum Latency time required before the IDE host controller as a bus-master can start an accesses.			

IDE PIO Timing – RW – 32 bits – [PCI_Reg:40h]			
Field Name	Bits	Default	Description
Primary Slave Data Register Command Recovery Width	3:0	9h	Slave Data register command recovery width for Primary IDE bus slave PIO device. Actual width will be setting + 1 PCICLK cycles.
Primary Slave Data Register Command width	7:4	9h	Slave Data register command width for Primary IDE bus slave PIO device. Actual width will be setting + 1 PCICLK cycles.
Primary Master Data Register Command Recovery Width	11:8	9h	Master Data register command recovery width for primary IDE bus Master PIO device. Actual width will be setting + 1 PCICLK cycles.
Primary Master Data Register Command Width	15:12	9h	Master Data register command width for Primary IDE bus Master PIO device. The actual width will be setting + 1 PCICLK cycles.
Secondary Slave Data Register Command Recovery Width	19:16	9h	Slave Data register command recovery width for Secondary IDE bus slave PIO device. Actual width will be setting + 1 PCICLK cycles.
Secondary Slave Data Register Command width	23:20	9h	Slave Data register command width for Secondary IDE bus slave PIO device. Actual width will be setting + 1 PCICLK cycles.
Secondary Master Data Register Command Recovery Width	27:24	9h	Master Data register command recovery width for Secondary IDE bus Master PIO device. Actual width will be setting + 1 PCICLK cycles.
Secondary Master Data Register Command Width	31:28	9h	Master Data register command width for Secondary IDE bus Master PIO device. The actual width will be setting + 1 PCICLK cycles.

IDE PIO Timing – RW – 32 bits – [PCI_Reg:40h]			
Field Name	Bits	Default	Description
IDE PIO Timing Register: This register controls the IDE interface and selects the timing of the PCI bus IDE PIO bus-master cycles. Note: Relation of setting value and actual timing of each mode are PIO Mode 4 3 2 1 0 Command Width 2(90ns) 2(90ns) 3(120ns)4(150ns)5(180ns) Recover Width 0(30ns) 2(90ns) 4(150ns)7(240ns) D(420n) The above timings are valid, when PCICLK in 33MHz and 66MHz. Actual timing is setting value + 1 PCI clock cycle.			

IDE Legacy DMA (Multi-words DMA) Timing Modes – RW – 32 bits – [PCI_Reg:44h]			
Field Name	Bits	Default	Description
Primary Slave DMA Command Recovery Width	3:0	Fh	Slave DMA command recovery width for Primary IDE bus Slave DMA device. Actual width will be setting+1 PCICLK cycles.
Primary Slave DMA Command Width	7:4	Fh	Slave DMA command width for Primary IDE bus Slave DMA device. Actual width will be setting+1 PCICLK cycles.
Primary Master DMA Command Recovery Width	11:8	Fh	Master DMA Command recovery width for primary IDE bus Master DMA device. Actual width will be setting+1 PCICLK cycles.
Primary Master DMA Command Width	15:12	Fh	Master DMA Command width for Primary IDE bus Master DMA device. The actual width will be setting+1 PCICLK cycles.
Secondary Slave DMA Command Recovery Width	19:16	Fh	Slave DMA command recovery width for Secondary IDE bus Slave DMA device. Actual width will be setting+1 PCICLK cycles.
Secondary Slave DMA Command Width	23:20	Fh	Slave DMA command width for Secondary IDE bus Slave DMA device. Actual width will be setting+1 PCICLK cycles.
Secondary Master DMA Command Recovery Width	27:24	Fh	Master DMA Command recovery width for Secondary IDE bus Master DMA device. Actual width will be setting+1 PCICLK cycles.
Secondary Master DMA Command Width	31:28	Fh	Master DMA Command width for Secondary IDE bus Master DMA device. The actual width will be setting+1 PCICLK cycles.
IDE Legacy DMA (Multi-words DMA) Timing Modes Register: This register controls the IDE interface and selects the timing of the PCI bus IDE DMA bus-master cycles. Note: Relation of setting value and actual timing of each mode are DMA Mode 2 1 0 Command Width 2(90ns) 2(90ns) 7(240ns) Recover Width 0(30ns) 1(60ns) 7(240ns) The above timings are valid, when PCICLK in 33MHz and 66MHz. Actual timing is setting value + 1 PCI clock cycle.			

IDE PIO Control - RW – 16 bits – [PCI_Reg:48h]			
Field Name	Bits	Default	Description
Primary IDE Disable	0	0b	Disables the primary IDE controller. When set, the primary IDE controller is disabled.
Reserved	3:1	0h	Reserved. Always read as 0's.
Reserved	4	0b	Reserved.
Reserved	5	0b	Reserved.
Reserved	6	0b	Reserved.
Reserved	7	0b	Reserved.
Secondary IDE Disable	8	0b	Disables secondary IDE controller. When set, the secondary IDE controller is disabled. (It is used only at SATA combined mode)
Reserved	11:9	0h	Reserved. Always read as 0's.
Reserved	12	0b	Reserved.
Reserved	13	0b	Reserved.

IDE PIO Control - RW – 16 bits – [PCI_Reg:48h]			
Field Name	Bits	Default	Description
Reserved	14	0b	Reserved.
Reserved	15	0b	Reserved.
IDE PIO Control Register: This register controls the IDE interface and selects the control functions of the PCI bus IDE PIO bus-master cycles.			

IDE PIO Mode – RW- 16 bits – [PCI_Reg:4Ah]			
Field Name	Bits	Default	Description
Primary Master PIO Access Mode	2:0	0h	PIO access mode for Primary IDE Master device. For example, PIO 0 = 000, PIO 1 = 001, ... etc..
Reserved	3	0b	Reserved. Always read as 0's.
Primary Slave PIO Access Mode	6:4	0h	PIO access mode for Primary IDE Slave device. For example, PIO 0 = 000, PIO 1 = 001, ... etc..
Reserved	7	0b	Reserved. Always read as 0's.
Secondary Master PIO Access Mode	10:8	0h	PIO access mode for Secondary IDE Master device. For example, PIO 0 = 000, PIO 1 = 001, ... etc..
Reserved	11	0b	Reserved. Always read as 0's.
Secondary Slave PIO Access Mode	14:12	0h	PIO access mode for Secondary IDE Slave device. For example, PIO 0 = 000, PIO 1 = 001, ... etc..
Reserved	15	0b	Reserved. Always read as 0's
IDE PIO Mode Register: This register specifies PIO modes primary channel.			

IDE Status – R- 8 bits – [PCI_Reg:4Ch]			
Field Name	Bits	Default	Description
Reserved	7:0	00h	Reserved. These bits always read as 0's.
IDE Status Register: This register specifies the IDE Status of primary channel.			

IDE Ultra DMAControl – RW- 8 bits – [PCI_Reg:54h]			
Field Name	Bits	Default	Description
Primary Master Ultra DMA enable	0	0b	Ultra DMA Enable Primary IDE Master device.
Primary Slave Ultra DMA enable	1	0b	Ultra DMA Enable Primary IDE Slave device.
Secondary Master Ultra DMA enable	2	0b	Ultra DMA Enable Secondary IDE Master device.
Secondary Slave Ultra DMA enable	3	0b	Ultra DMA Enable Secondary IDE Slave device.
Reserved	6:4	0h	Reserved. These bits always read as 0's.
Ultra DMA Report Mode	7	0b	Report Mode. When host receives last data as extra word, reporting will be: If this bit is 1, set IDE Ultra DMA Status register only. If this bit is 0, clear the interrupt bit of BusMaster Status Register and also set IDE Ultra DMA Status Register.
IDE Ultra DMA Control Register: This register specifies the IDE Control of primary channel.			

IDE Ultra DMA Status – RW- 8 bits – [PCI_Reg:55h]			
Field Name	Bits	Default	Description
Extra Data Status	0	0b	Transaction is complete, but internal buffer has some data. This bit will be cleared by resetting the dma start bit.
Reserved	3:1	0h	Reserved. Always read as 0's.
Reserved	4	0b	Reserved. Always read as 0's
Reserved	7:5	0h	Reserved. Always wired as 0's.
IDE Ultra DMA Status Register: This register specifies the Ultra DMA status for primary channel.			

IDE Ultra DMA Mode – RW- 16 bits – [PCI_Reg:56h]			
Field Name	Bits	Default	Description
Primary Master Ultra DMA Access Mode	2:0	0h	Ultra DMA access mode for Primary IDE master device. For instance, UDMA-5 = 101, UDMA-6 = 110.
Reserved	3	0b	Reserved. Always read as 0's.
Primary Slave Ultra DMA Access Mode	6:4	0h	Ultra DMA access mode for Primary IDE Slave device. For instance, UDMA-5 = 101, UDMA-6 = 110.
Reserved	7	0b	Reserved. Always wired as 0's.
Secondary Master Ultra DMA Access Mode	10:8	0h	Ultra DMA access mode for Secondary IDE master device. For instance, UDMA-5 = 101, UDMA-6 = 110.
Reserved	11	0b	Reserved. Always read as 0's.
Secondary Slave Ultra DMA Access Mode	14:12	0h	Ultra DMA access mode for Secondary IDE master device. For instance, UDMA-5 = 101, UDMA-6 = 110.
Reserved	15	0b	Reserved. Always wired as 0's.
IDE Ultra DMA Mode Register: This register specifies the Ultra DMA timings for primary channel.			

IDE PCI Retry Timing Counter – RW- 8 bits – [PCI_Reg:60h]			
Field Name	Bits	Default	Description
PCI Retry Timing Counter	3:0	0h	Waiting number of PCI clocks. If a PCI Master transaction is retried, the IDE host controller will wait for 0-15 PCI clocks, depending upon the value programmed, and will re-issue the PCI master transaction.
Reserved	7:4	0h	Reserved. Always wired as 0's.
IDE PCI Retry Timing Counter Register: This register specifies the Ultra DMA re-try timings for primary channel.			

PCI Error Control – RW- 8 bits – [PCI_Reg:61h]			
Field Name	Bits	Default	Description
PCI Data Parity Check Ignore	0	0b	0: Check parity bit for DMA transaction. 1: Ignore parity bit for DMA transaction. If there is a parity error with a DMA transaction, the IDE host controller does not set the error bit (Bus Master IDE Reg.) If this bit is 1, bit 1 is “don't care.” (same as bit 1=0.)
PCI Descriptor DMA Abort Enable	1	0b	0: DMA will not be aborted by PCI parity error at descriptor table read. 1: DMA will be aborted by PCI parity error at descriptor table read.
PCI Master/Target Abort Ignore	2	0b	0: DMA will be aborted by parity error, master abort, and target abort at data transaction (if bit0=1 or bit1=0, DMA does not abort by parity error.) 1: DMA does not abort by parity error, master abort, and target abort at data transaction.
Reserved	7:3	00h	Reserved. Always hardwired as 0's.
PCI Error Control Register: This register specifies DMA parity bit errors.			

IDE Internal Control – RW- 16 bits – [PCI_Reg:62h]			
Field Name	Bits	Default	Description
IDE Internal PCI master request selection	0	0b	Selects number of delay cycles on internal PCI master request 0: Delay two PCI cycles 1: Delay three PCI cycles
IDE PCI request control	1	0b	Controls PCI request deassertion timing at PCI retry cycle. 0: Allows IDE's PCI request to be deasserted one cycle early. 1: PCI request will be deasserted one cycle late.
Reserved	3:2	0h	Reserved.
Reserved	5:4	0h	Reserved. Always read as 0's
IDE Fast sampling Enable	6	1b	Enables fast sampling on IORDY (DDMARDY#) port 0: Use regular ide clock to sample 1: Use either (50/66MHz) sampling IORDY (DDMARDY#) port at ultra dma mode
Reserved	7	0b	Reserved.
Explicit/Implicit prefetch Switch	8	0b	Controls implicit or explicit prefetch function 0: Explicit prefetch is enabled 1: Implicit prefetch is enabled (support from SB450/460/600/700)
Secondary channel software disable	9	1b	BIOS can program this bit to disable secondary IDE channel under Windows® device manager
Primary channel software disable	10	1b	BIOS can program this bit to disable primary IDE channel under Windows device manager
Reserved	12:11	0h	Reserved.
Message-Signaled Interrupt (MSI) Capability control	13	0b	Allow programming MSI Capable bit (pci configuration offset 0x70 bit[19:17]) if set to 1
SATA BAR 5/SATA PCI configuration access control	14	0h	If combined mode is enabled, the Index Addressing Pair (IDP) access for SATA BAR5 or SATA PCI configuration space determined by, 0: Accessing SATA PCI configuration space 1: Accessing SATA BAR 5 space
MSI_MME[0]control bit	15	0b	Control Multiple/Single Message Enable 0: Only 1 message allocated 1: 2 messages allocated
IDE Internal Control Register: This register can enable internal PCI request timing and different IDE arbitration schemes.			

IDE Misc. Control - RW- 32 bits - [PCI_Reg:64h]			
Field Name	Bits	Default	Description
Reserved	0	0b	Reserved.
IDE Internal Logic Reset	1	0b	IDE internal reset. This reset follows IDE PLL reset. Software control the duration between both resets.
IDE Channel Tri-state Mode	2	0b	IDE channel tri-state mode if it is set to 1.
Reserved	3	0b	Reserved. Always read as 0's.
Preliminary Buffer Threshold Control	6:4	001b	Programmable threshold control for preliminary buffer.
Reserved	7	0b	Reserved. Always read as 0's.
Reserved	10:8	100b	Reserved.
Reserved	13:11	101b	Reserved.
Reserved	15:14	00b	Reserved.
Reserved	21:16	01h	Reserved.
Reserved	31:22	01Ch	Reserved.
IDE Misc. Control Register: This register specifies IDE tri-state channel enable, and preliminary buffer threshold control.			

IDE MSI Programmable Weight - RW- 8 bits - [PCI_Reg:68h]			
Field Name	Bits	Default	Description
MSI Interrupt Weight	5:0	01h	MSI programmable interrupt weight.
Reserved	7:6	0h	Reserved. Always wired as 0's.
IDE MSI Programmable Weight Register: This register specifies MSI weight.			

IDE Dynamic Clocking - RW- 20 bits - [PCI_Reg:6Ch]			
Field Name	Bits	Default	Description
IDE Power Down Counter	19:0	FFFFh	The IDE power down counter can be programmed to shut down the IDE clock. The counter is running at 66Mhz clock. If the value is set to 0x3FF, it means that the IDE controller detects that the bus is without activity for more than 15us, the internal clock is powered down for advance power saving. Any detected activity will turn the clock back on. The default is FFFFh and dynamic clocking is disabled.
Reserved	31:20	000h	Reserved. Always wired as 0's.
IDE Dynamic Clocking Register: This register specifies the time (in number of IDE clocks) to shut down the IDE clock after there are no more IDE transactions. Note: A 32-bit double-word (DW) PCI configuration write is required to update this register.			

IDE MSI Control - RW- 32 bits - [PCI_Reg:70h]			
Field Name	Bits	Default	Description
Capability ID	7:0	05h	Capability ID (hard_wired to 05h)
Capability Next Pointer	15:8	00h	Next Pointer (hard_wired to 00h)
Message Signaled Interrupt Enable	16	0b	MSI Enable (MSI_En)
Multiple Message Capable	19:17	0h	Multiple Message Capable (MMC). Default is set to 4 MSI interrupts assigned to SATA, one for each SATA port.
Multiple Message Enable	22:20	0h	Multiple Message Enable (MME) (hard_wired to 0h)
MSI 64-bit Address	23	0b	64-bit address (hard_wired to 0b)
Reserved	31:24	00h	Reserved. Always wired as 0's.
IDE MSI Control Register: This register specifies MSI Capability ID, next pointer, MSI enable, multiple message capable, multiple message enable bits.			

IDE MSI Address Register - RW- 32 bits - [PCI_Reg:74h]			
Field Name	Bits	Default	Description
IDE MSI Address	31:0	0000_0000h	MSI Address
IDE MSI Address Register: This register specifies MSI address.			

IDE MSI Data Register - RW- 16 bits - [PCI_Reg:78h]			
Field Name	Bits	Default	Description
IDE MSI Data	15:0	0000h	MSI Data
IDE MSI Data Register: This register specifies MSI data.			

IDE Index-Data-Pair (IDP) Address Register - RW- 16 bits - [PCI_Reg:80h]			
Field Name	Bits	Default	Description
Reserved	1:0	00b	Reserved. Always wired as 0's.
IDE IDP Address	10:2	000h	Index-data-pair Address
IDE IDP Address Register: This register specifies indirect address to access SATA PCI configuration space and memory space pointed by BAR 5.			

2.5 HD Audio Controller Registers

HD Audio controller registers are supported in PCI configuration and Memory space. These registers are cleared by the PCIRST# signal; therefore, they will be cleared on a warm boot.

Note: Some HD Audio functions are controlled by, and associated with, certain PCI configuration registers in the SMBus/ACPI device. For more information refer to [section 2.4: SMBus Module and ACPI Block \(Device 20, Function 0\)](#).

2.5.1 HD Audio Controller PCI Configuration Space Registers (Device 20 Function 2)

The PCI Configuration Space Registers define the operation of the SP5100's HD Audio Controller. These registers are accessible only when the HD Audio Controller detects a Configuration Read or Write operation, with its IDSEL asserted.

Register Name	Address Offset
Device ID	00h
Vendor ID	02h
PCI Command	04h
PCI Status	06h
Revision ID	08h
Prog . Interface	09h
Sub Class Code	0Ah
Base Class Code	0Bh
Cache Line Size	0Ch
Latency Timer	0Dh
Header Type	0Eh
BIST	0Fh
Lower Base Address Register	10h
Upper Base Address Register	14h
Subsystem Vendor ID	2Ch
Subsystem ID	2Eh
Capabilities Ptr	34h
Interrupt Line	3Ch
Interrupt Pin	3Dh
Min Grant	3Eh
Max Latency	3Fh
Misc Control 1	40h
Misc Control 2	42h
Misc Control 3	43h
Intr Pin Control	44h
Debug Control	46h
Power Management Capability ID	50h
Power Management Capabilities	52h
Power Management Control/Status	54h
MSI Capability ID	60h
MSI Message Control	62h
MSI Lower Address	64h
MSI Upper Address	68h
MSI Message Data	6Ch

Vendor ID – R – 16 bits – [PCI_Reg: 00h]			
Field Name	Bits	Default	Description
Vendor ID	15:0	1002h	Identifies the vendor as AMD

Device ID – R/W – 16 bits – [PCI_Reg: 02h]			
Field Name	Bits	Default	Description
Device ID	15:0	4383h	Identifies this device as HD Audio Controller

PCI Command – R/W – 16 bits – [PCI_Reg: 04h]			
Field Name	Bits	Default	Description
Reserved	0	0b	Reserved.
Memory Space Enable	1	0b	Memory Space Enable. This bit enables the HD Audio controller to respond to PCI memory space access.
Bus Master Enable	2	0b	This bit set enables the HD Audio controller's bus mastering capability.
Reserved	9:3	00h	Reserved
Interrupt Disable	10	0b	Interrupt Disable. This bit disables the device from asserting INTx#. Note: This bit does not affect the generation of MSI.
Reserved	15:11	00h	Reserved

PCI Status – R/W – 16 bits – [PCI_Reg: 06h]			
Field Name	Bits	Default	Description
Reserved	2:0	0h	Reserved
Interrupt Status	3	0b	Interrupt status. This bit is a "1" when INTx# is asserted. Note: This bit is not set by MSI.
Capabilities List	4	1b	PCI Capabilities List. This bit is hardwired to 1 to indicate that the HD Audio controller contains a capability pointer list. The first item at offset 34h
Reserved	12:5	00h	Reserved
Received Master Abort	13	0b	This bit set indicates that the HD Audio controller terminated a PCI bus operation with a Master Abort.
Reserved	15:14	0h	Reserved

Revision ID – R – 8 bits – [PCI_Reg: 08h]			
Field Name	Bits	Default	Description
Revision ID	7:0	00h	Chip Revision ID. This field is hardwired to 0 to indicate the revision level of the chip design.

Programming Interface – R – 8 bits – [PCI_Reg: 09h]			
Field Name	Bits	Default	Description
Programming Interface	7:0	00h	Programming Interface.

Sub Class Code – R – 8 bits – [PCI_Reg: 0Ah]			
Field Name	Bits	Default	Description
Sub Class Code	7:0	03h	Sub Class Code. Indicates a HD Audio device in the context of a multimedia device class.

Base Class Code – R – 8 bits – [PCI_Reg: 0Bh]			
Field Name	Bits	Default	Description
Base Class Code	7:0	04h	Base Class Code. Indicates a multimedia device.

Cache Line Size – R/W – 8bits – [PCI_Reg: 0Ch]			
Field Name	Bits	Default	Description
Cache Line Size	7:0	00h	This field is implemented as a read/write field for legacy compatibility purposes only and has no functional impact.

Latency Timer – R – 8 bits – [PCI_Reg: 0Dh]			
Field Name	Bits	Default	Description
Latency Timer	7:0	00h	Hardwired to 0.

Header Type – R – 8 bits – [PCI_Reg: 0Eh]			
Field Name	Bits	Default	Description
Header Type	7:0	00h	Hardwired to 0.

BIST – R – 8 bits – [PCI_Reg: 0Fh]			
Field Name	Bits	Default	Description
BIST	15:0	0000h	Hardwired to 0.

Lower Base Address Register – R/W – 32 bits – [PCI_Reg: 10h]			
Field Name	Bits	Default	Description
Space Type	0	0	Hardwired to 0 to indicate this BAR is located in memory space only.
Address Range	2:1	10b	Hardwired to “10” to indicate this BAR can be located anywhere in 64-bit address space.
Prefetchable	3	0b	Hardwired to 0 to indicate this BAR is not prefetchable.
Reserved	13:4	000h	Hardwired to 0.
Lower Base Address	31:14	00000h	Lower Base Address for the HD Audio controller’s memory mapped configuration registers. 16K bytes are requested by hardwiring bits[13:4] to 0.

Upper Base Address Register – R/W – 32 bits – [PCI_Reg: 14h]			
Field Name	Bits	Default	Description
Upper Base Address	31:0	00000000 h	Upper Base Address for the HD Audio controller's memory mapped configuration registers.

Subsystem Vendor ID – R/W – 16 bits – [PCI_Reg: 2Ch]			
Field Name	Bits	Default	Description
Subsystem Vendor ID	15:0	0000h	This register is implemented as write-once register. Any subsequent writes have no effect.

Subsystem ID – R/W – 16 bits – [PCI_Reg: 2Dh]			
Field Name	Bits	Default	Description
Subsystem ID	15:0	0000h	This register is implemented as write-once register. Any subsequent writes have no effect.

Reset Value: 0

Capabilities Pointer – R – 8 bits – [PCI_Reg: 34h]			
Field Name	Bits	Default	Description
Capabilities Pointer	7:0	50h	This register indicates the offset for the capability pointer

Interrupt Line – R/W – 8 bits – [PCI_Reg: 3Ch]			
Field Name	Bits	Default	Description
Interrupt Line	7:0	00h	This register is used to communicate to software the interrupt line that the interrupt pin is connected to. It is not used by the HD Audio controller.

Interrupt Pin – R – 8 bits – [PCI_Reg: 3Dh]			
Field Name	Bits	Default	Description
Interrupt Pin	3:0	1h	This register reflects the value programs into Interrupt Control Pin register at offset 44h, bits[3:0]
Reserved	7:4	0h	Reserved

Minimum Grant – R – 8 bits – [PCI_Reg: 3Eh]			
Field Name	Bits	Default	Description
Minimum Grant	7:0	00h	Hardwired to 0.

Maximum Latency – R – 8 bits – [PCI_Reg: 3Fh]			
Field Name	Bits	Default	Description
Maximum Latency	7:0	00h	Hardwired to 0.
Reset Value: 0			

Misc Control 1 – R/W – 16 bits – [PCI_Reg: 40h]			
Field Name	Bits	Default	Description
Static Output FIFO Size Select	1:0	00b	Static Output FIFO Size is functional only when the Static Output FIFO Size Enable bit is set to "1". 00: One-eighth of the maximum Output FIFO Size 01: One-quarter of the maximum Output FIFO size 10: One-half of the maximum Output FIFO Size 11: Use the maximum Output FIFO Size
Reserved	7:2	00h	Reserved
Static Output FIFO Size Enable	8	0b	Enables Static Output FIFO Size otherwise Output FIFO Size is set dynamically set based on Stream Format.
Reserved	15:9	00h	Reserved.

Misc Control 2 Register – R/W – 8 bits – [PCI_Reg: 42h]			
Field Name	Bits	Default	Description
Disable No Snoop	0	0b	1: No Snoop attribute is disabled on Buffer Descriptor and Data Buffer DMA. 0: Set the No Snoop attribute on Buffer Descriptor and Data Buffer DMA when the Traffic Priority bit is set in the Stream Descriptor.
Disable No Snoop Override	1	0b	1: Bit [0] of this register controls the No Snoop attribute 0: Override the bit[0] setting meaning always generate No Snoop attribute on Buffer Descriptor and Data Buffer DMA
Enable No Snoop Request	2	0b	1: Enable No Snoop request to ACPI 0: Disable No snoop request to ACPI When enabled and the DMA cycle is No Snoop, ACPI will not generate a wake to CPU in C2 state.
Reserved	3	0b	Reserved
Reserved	5:4	0b	Reserved
Reserved	7:6	00h	Reserved

Misc Control 3 Register – R/W – 8 bits – [PCI_Reg: 43h]			
Reserved	7:0	00h	Reserved

Interrupt Pin Control Register – R/W – 8 bits – [PCI_Reg: 44h]			
Field Name	Bits	Default	Description
Interrupt Pin Control	3:0	1h	Controls the value reports in Interrupt Pin Register at offset 3Dh.
Reserved	7:4	00h	Reserved

Debug Control Register – R/W – 16 bits – [PCI_Reg: 46h]			
Field Name	Bits	Default	Description
Input DMA Debug Select	1:0	00b	Selects one of four Input DMA debug signals
Output DMA Debug Select	3:2	00b	Selects one of four Output DMA debug signals
Link Input Debug Select	5:4	00b	Selects one of four Link Input debug signals
Link Output Debug Select	7:6	00b	Selects one of Link Output debug signals
Misc Debug Select	8	0b	Selects one of two sets of misc debug signals
Reserved	14:9	00h	Reserved
HD Audio Link Short Reset Enable	15	0b	1: Shorten HD Audio Link reset timing for simulation/test purposes 0: Normal reset timing operation

Power Management Capability ID – R – 16 bits – [PCI_Reg: 50h]			
Field Name	Bits	Default	Description
Capability ID	7:0	01h	Hardwired to 0x01. Indicates PCI Power Management Capability.
Next Capability Pointer	15:8	60h	Hardwired to 0x60. Next capability is at offset 0x60

Power Management Capabilities – R – 16 bits – [PCI_Reg: 52h]			
Field Name	Bits	Default	Description
Version	2:0	010b	Hardwired to 010b. Indicates this function complies with Revision 1.1 of the PCI Power Management Interface Specification
PME Clock	3	0b	Hardwired to 0. Indicates that no PCI clock is required for the function to generate PME#.
Reserved	4	0b	Reserved
Device Specific Initialization	5	0b	Hardwired to 0. Indicates that no device specific initialization is required.
Aux Current	8:6	001b	Hardwired to 001b. Indicates 55mA maximum suspend well current is required in the D3cold state.
D1 Support	9	0b	Hardwired to 0. Indicates D1 state is not supported.
D2 Support	10	0b	Hardwired to 0. Indicates D2 state is not supported.
PME Support	15:11	11001b	Hardwired to 11001b. Indicates PME# can be generated from D0 and D3 states.

Power Management Control/Status – R/W – 32 bits – [PCI_Reg: 54h]			
Field Name	Bits	Default	Description
Power State	1:0	00b	This field is used both to determine the current power state and to set a new power state of the HD Audio controller.
Reserved	7:2	00h	Reserved
PME Enable	8	0b	Enables the function to assert PME#. This bit is in resume well and only cleared on power-on reset.
Reserved	14:9	00h	Reserved
PME Status	15	0b	This bit set when when HD Audio controller asserts the PME# signal, it is independent of the PME Enable bit. Writing a “1” clears this bit. This bit is in resume well and only cleared on power-on reset.
Reserved	31:16	0000h	Reserved

MSI Capability ID – R – 16 bits – [PCI_Reg: 60h]			
Field Name	Bits	Default	Description
Capability ID	7:0	05h	Hardwired to 0x05. Indicates MSI Capability.
Next Capability Pointer	15:8	0b	Hardwired to 0. Indicates this is the last capability structure in the list.

MSI Message Control – R/W - 16 bits – [PCI_Reg: 62h]			
Field Name	Bits	Default	Description
MSI Enable	0	0b	Enables MSI if set to 1.
Multiple Message Capable	3:1	0h	Hardwired to 0. Indicates support for one message only.
Multiple Message Enable	6:4	0h	Hardwired to 0. Indicates support for one message only.
64 Bit Address Capability	7	1b	Hardwired to 1. Indicates the ability to generate 64-bit message address.
Reserved	15:8	00h	Reserved

MSI Message Lower Address – R/W - 32 bits – [PCI_Reg: 64h]			
Field Name	Bits	Default	Description
MSI Message Lower Address	31:2	00000000 h	Lower Address used for MSI Message.
Reserved	01:0	00b	Reserved

MSI Message Upper Address – R/W - 32 bits – [PCI_Reg: 68h]			
Field Name	Bits	Default	Description
MSI Message Upper Address	31:0	00000000 h	Upper Address used for MSI Message.

MSI Message Data – R/W - 16 bits – [PCI_Reg: 6Ch]			
Field Name	Bits	Default	Description
MSI Message Data	15:00	0000h	Data used for MSI Message.

2.5.2 HD Audio Controller Memory Mapped Registers

The base memory location for these memory mapped registers is specified in the PCI Configuration Upper and Lower Base Address Registers. The individual registers are then accessible at Base + offset as indicated in the following table. These registers are accessed in byte, word, or dword quantities.

Register Name	Address Offset
Global Capabilities	00h
Minor Version	02h
Major Version	03h
Output Payload Capability	04h
Input Payload Capability	06h
Global Control	08h
Wake Enable	0Ch
Wake Status	0Eh
Global Status	10h
Output Stream Payload Capability	18h
Input Stream Payload Capability	1Ah
Interrupt Control	20h
Interrupt Status	24h
Wall Clock Counter	30h
Stream Synchronization	38h
CORB Lower Base Address	40h
CORB Upper Base Address	44h
CORB Write Pointer	48h
CORB Read Pointer	4Ah
CORB Control	4Ch
CORB Status	4Dh
CORB Size	4Eh
RIRB Lower Base Address	50h
RIRB Upper Base Address	54h
RIRB Write Pointer	58h
Response Interrupt Control	5Ah
RIRB Control	5Ch
RIRB Status	5Dh
RIRB Size	5Eh
Immediate Command Output Interface	60h
Immediate Command Input Interface	64h
Immediate Command Status	68h
DMA Position Buffer Lower Base Address	70h
DMA Position Buffer Upper Base Address	74h
Input Stream Descriptor 0	
Control	80h
Status	83h
Link Position in Current Buffer	84h
Cyclic Buffer Length	88h
Last Valid Index	8Ch
FIFO Size	90h
Stream Format	92h
Buffer Descriptor Lower Base Address	98h
Buffer Descriptor Upper Base Address	9Ch
Input Stream Descriptor 1	
Control	A0h
Status	A3h
Link Position in Current Buffer	A4h
Cyclic Buffer Length	A8h
Last Valid Index	ACh

Register Name	Address Offset
FIFO Size	B0h
Stream Format	B2h
Buffer Descriptor Lower Base Address	B8h
Buffer Descriptor Upper Base Address	BCh
Input Stream Descriptor 2	
Control	C0h
Status	C3h
Link Position in Current Buffer	C4h
Cyclic Buffer Length	C8h
Last Valid Index	CCh
FIFO Size	D0h
Stream Format	D2h
Buffer Descriptor Lower Base Address	D8h
Buffer Descriptor Upper Base Address	DCh
Input Stream Descriptor 3	
Control	E0h
Status	E3h
Link Position in Current Buffer	E4h
Cyclic Buffer Length	E8h
Last Valid Index	ECh
FIFO Size	F0h
Stream Format	F2h
Buffer Descriptor Lower Base Address	F8h
Buffer Descriptor Upper Base Address	FCh
Output Stream Descriptor 0	
Control	100h
Status	103h
Link Position in Current Buffer	104h
Cyclic Buffer Length	108h
Last Valid Index	10Ch
FIFO Size	110h
Stream Format	112h
Buffer Descriptor Lower Base Address	118h
Buffer Descriptor Upper Base Address	11Ch
Output Stream Descriptor 1	
Control	120h
Status	123h
Link Position in Current Buffer	124h
Cyclic Buffer Length	128h
Last Valid Index	12Ch
FIFO Size	130h
Stream Format	132h
Buffer Descriptor Lower Base Address	138h
Buffer Descriptor Upper Base Address	13Ch
Output Stream Descriptor 2	
Control	140h
Status	143h
Link Position in Current Buffer	144h
Cyclic Buffer Length	148h
Last Valid Index	14Ch
FIFO Size	150h
Stream Format	152h
Buffer Descriptor Lower Base Address	158h
Buffer Descriptor Upper Base Address	15Ch
Output Stream Descriptor 3	
Control	160h
Status	163h
Link Position in Current Buffer	164h

Register Name	Address Offset
Cyclic Buffer Length	168h
Last Valid Index	16Ch
FIFO Size	170h
Stream Format	172h
Buffer Descriptor Lower Base Address	178h
Buffer Descriptor Upper Base Address	17Ch
Alias Registers	
Wall Clock Counter Alias	2030h
Input Stream Descriptor 0 - Link Position in Current Buffer Alias	2084h
Input Stream Descriptor 1 - Link Position in Current Buffer Alias	20A4h
Input Stream Descriptor 2 - Link Position in Current Buffer Alias	20C4h
Input Stream Descriptor 3 - Link Position in Current Buffer Alias	20E4h
Output Stream Descriptor 0 - Link Position in Current Buffer Alias	2104h
Output Stream Descriptor 1 - Link Position in Current Buffer Alias	2124h
Output Stream Descriptor 2 - Link Position in Current Buffer Alias	2144h
Output Stream Descriptor 3 - Link Position in Current Buffer Alias	2164h

Global Capabilities – R – 16 bits - [Mem_Reg: Base + 00h]			
Field Name	Bits	Default	Description
64 Bit Address Supported	0	1	Hardwired to 1. Indicates that 64-bit addressing capability is supported by the HD Audio controller for BDL, Data Buffer, Command Buffer, and Response Buffer addresses.
Number of Serial Data Output Signals	2:1	0	Hardwired to 0. Indicates that one SDO line is supported.
Number of Bidirectional Streams Supported	7:3	0	Hardwired to 0. Indicates that bidirectional stream is not supported.
Number of Input Streams Supported	11:8	4h	4 Input Streams are supported.
Number of Output Streams Supported	15:12	4h	4 Output Streams are supported.

Minor Version – R – 8 bits - [Mem_Reg: Base + 02h]			
Field Name	Bits	Default	Description
Minor Version	31:2	00000000h	Hardwired to 0.

Major Version – R – 8 bits - [Mem_Reg: Base + 03h]			
Field Name	Bits	Default	Description
Major Version	0	1b	Hardwired to 1.

Output Payload Capability – R – 16 bits - [Mem_Reg: Base + 04h]			
Field Name	Bits	Default	Description
Output Payload Capability	15:0	003Ch	Hardwired to 3Ch. Indicates the total output payload on the link. This does not include bandwidth used for command and control. This measurement is in 16-bit word quantities per 48kHz frame. The default link clock speed of 24MHz (double data rate) provides 1000 bits per frame minus 40 bits for command and control, leaving 960 bits (60 words) for data payload.

Input Payload Capability – R – 16 bits - [Mem_Reg: Base + 06h]			
Field Name	Bits	Default	Description
Input Payload Capability	15:0	001Dh	Hardwired to 1Dh. Indicates the total input payload on the link. This does not include bandwidth used for response. This measurement is in 16-bit word quantities per 48kHz frame. The default link clock speed of 24MHz provides 500 bits per frame minus 36 bits for response, leaving 464 bits (29 words) for data payload.

Global Control – R/W – 32 bits - [Mem_Reg: Base + 08h]			
Field Name	Bits	Default	Description
Controller Reset	0	0b	Writing a 0 to this bit causes the controller to transition to the Reset state. After the hardware has completed sequencing into the Reset state, it will report a 0 in this bit. Software must read a 0 from this bit to verify that the controller is in reset. Writing a 1 to this bit causes the controller to exit the Reset state and deassert the link RESET# signals. Software is responsible for setting/clearing this bit such that the minimum link RESET# signal assertion pulse width specification is met. When the controller hardware is ready to begin operation, it will report a 1 in this bit. Software must read a 1 from this bit before accessing any controller registers.
Flush Control	1	0b	Writing a 1 to this bit initiates a flush. The flush is completed when Flush Status is set.
Reserved	7:2	00h	Reserved. Software must do a read-modify-write to preserve the value of these bits.
Accepted Unsolicited Response Enable	8	0b	If “1”, Unsolicited Response from the codecs are accepted by the controller and placed into the Response Input Ring Buffer. If “0”, Unsolicited Responses are accepted and dropped.
Reserved	31:9	000000h	Reserved. Software must do a read-modify-write to preserve the value of these bits.

Wake Enable – R/W – 16 bits - [Mem_Reg: Base + 0Ch]			
Field Name	Bits	Default	Description
Wake Enable	3:0	0h	This field controls which SDIN signals may generate a wake event in response to a codec State Change event. Bit [0] corresponds to Codec 0 – SDIN[0] Bit [1] corresponds to Codec 1 – SDIN[1] Bit [2] corresponds to Codec 2 – SDIN[2] Bit [3] corresponds to Codec 3 – SDIN[3] These bits are only cleared by a power-on reset.
Reserved	15:4	000h	Reserved. Software must do a read-modify-write to preserve the value of these bits.

State Change Status – R/W – 16 bits - [Mem_Reg: Base + 0Eh]			
Field Name	Bits	Default	Description
State Change Status Flags	3:0	0h	This field indicates which SDIN signal(s) received a State Change event. Bit [0] corresponds to Codec 0 – SDIN[0] Bit [1] corresponds to Codec 1 – SDIN[1] Bit [2] corresponds to Codec 2 – SDIN[2] Bit [3] corresponds to Codec 3 – SDIN[3] These bits are cleared by writing 1's to them. These bits are only cleared by a power-on reset.
Reserved (R/W)	15:4	000h	Reserved. Software must do a read-modify-write to preserve the value of these bits.

Global Status – R/W – 16 bits - [Mem_Reg: Base + 10h]			
Field Name	Bits	Default	Description
Reserved	0	0b	Reserved. Software must use 0 for write to this bit.
Flush Status	1	0b	This bit is set to a “1” by hardware to indicate that the flush cycle initiated by setting the Flush Control has completed. Software must write a “1” to clear this bit before the next time Flush Control is set.
Reserved	15:2	0000h	Reserved. Software must use 0's for write to these bits.

Output Stream Payload Capability – R – 16 bits - [Mem_Reg: Base + 18h]			
Field Name	Bits	Default	Description
Output Stream Payload Capability	15:0	003Ch	This field indicates the maximum number of words per frame for any single output stream. This measurement is in 16-bit word quantities per 48 kHz frame. The value must not be greater than the Output Payload Capability register value. Software must ensure that a format which would cause more words per frame than indicated is not programmed into the Output Stream Descriptor register. 00h: No Limit (Stream size is limited only by Output Payload Capability register) 01h: 1 word payload : : FFh: 255 word payload

Input Stream Payload Capability – R – 16 bits - [Mem_Reg: Base + 1Ah]			
Field Name	Bits	Default	Description
Input Stream Payload Capability	15:0	0000h	This field indicates the maximum number of words per frame for any single input stream. This measurement is in 16-bit word quantities per 48 kHz frame. The value must not be greater than the Input Payload Capability register value. Software must ensure that a format which would cause more words per frame than indicated is not programmed into the Input Stream Descriptor register. 00h: No Limit (Stream size is limited only by Input Payload Capability register) 01h: 1 word payload : : FFh: 255 word payload

Interrupt Control – R/W – 32 bits - [Mem_Reg: Base + 20h]			
Field Name	Bits	Default	Description
Stream Interrupt Enable	7:0	00h	When set to “1”, the individual streams are enabled to generate an interrupt when the corresponding stream status bits are set. A stream interrupt is caused as a result of a buffer with IOC in the BDL entry being completed or as result of FIFO error. Control over the generation of each of these sources is in the associated Stream Descriptor. Bit [0]: Input Stream 0 Bit [1]: Input Stream 1 Bit [2]: Input Stream 2 Bit [3]: Input Stream 3 Bit [4]: Output Stream 0 Bit [5]: Output Stream 1 Bit [6]: Output Stream 2 Bit [7]: Output Stream 3
Reserved	29:8	000000h	Reserved
Controller Interrupt Enable	30	0b	Enables the general interrupt for controller functions. When set to “1”, the controller generates an interrupt when the corresponding status bit gets set due to a Response Interrupt, a Response Buffer Overrun, and Wake events.
Global Interrupt Enable	31	0b	Enables device interrupt generation. When set to “1”, the HD Audio device is enabled to generate an interrupt. This control is in addition to any bits in the bus specific address space such as the Interrupt Enable bit in the PCI Configuration Space.

Interrupt Status – R/W – 32 bits - [Mem_Reg: Base + 24h]			
Field Name	Bits	Default	Description
Stream Interrupt Status	7:0	00h	An “1” indicates that an interrupt condition occurred on the corresponding stream. These bits are cleared by writing 1’s to them. Note that these bits are set regardless of the state of the corresponding Interrupt Enable bits.
Reserved	29:8	000000h	Reserved
Controller Interrupt Status	30	0b	A “1” indicates that an interrupt condition occurred. This bit is cleared by writing a “1” to it. Note that this bit is set regardless of the state of the corresponding Interrupt Enable bit.
Global Interrupt Status	31	0b	This bit is an “OR” of all the interrupt status bits in this register.

Wall Clock Counter – R – 32 bits - [Mem_Reg: Base + 30h]			
Field Name	Bits	Default	Description
Wall Clock Counter	31:0	00000000h	32 bit counter that is incremented at the link bitclock rate and rolls over from FFFF_FFFFh to 0000_0000h. This counter will roll over to 0 with period of approximately 179 seconds with the nominal 24 MHz bitclock rate.

Stream Synchronization – R/W – 32 bits – [Mem_Reg: Base + 38h]			
Field Name	Bits	Default	Description
Stream Synchronization	7:0	00h	These bits when set, block data from being sent on or received from the link. Each bit controls the associated Stream Descriptor. To synchronously start a set of DMA engines, the bits in this register are set to a “1”. The RUN bits for the associated Stream Descriptors can be set to a “1” to start the DMA engines. When all streams are ready, the associated Stream Synchronization bits can all be set to 0 at the same time, and transmission or reception from the link will begin together at the start of the next full link frame. To synchronously stop streams, these bits are set, and the RUN bits in the Stream Descriptors are cleared by software.
Reserved	31:8	000000h	Reserved. Software must do a read-modify-write to preserve the value of these bits.

CORB Lower Base Address – R/W – 32 bits – [Mem_Reg: Base + 40h]			
Field Name	Bits	Default	Description
CORB Lower Base Address Unimplemented Bits	6:0	00h	Hardwired to 0. This forces 128-byte buffer alignment for cache line fetch optimizations.
CORB Lower Base Address	31:7	0000000h	Upper 25 bits of the 32 bits Lower Base address of the Command Output Ring Buffer, allowing the CORB Base Address to be assigned on any 1 KB boundary. This register must not be written when the DMA engine is running or the DMA transfer may be corrupted.

CORB Upper Base Address – RW – 32 bits – [Mem_Reg: Base + 44h]			
Field Name	Bits	Default	Description
CORB Upper Base Address	31:0	00000000h	Upper 32 bits address of the CORB. This register must not be written when the DMA engine is running or the DMA transfer may be corrupted.

CORB Write Pointer – R/W – 16 bits – [Mem_Reg: Base + 48h]			
Field Name	Bits	Default	Description
CORB Write Pointer	7:0	00h	Software writes the last valid CORB entry offset into this field in dword granularity. The DMA engine fetches commands from the CORB until the Read Pointer matches the Write Pointer. This supports up to 256 CORB entries. This field may not be written while the DMA engine is running.
Reserved	15:8	00h	Reserved. Software must do a read-modify-write to preserve the value of these bits.

CORB Read Pointer – R/W – 16 bits – [Mem_Reg: Base + 4Ah]			
Field Name	Bits	Default	Description
CORB Read Pointer	7:0	00h	Software reads this field to determine how many commands it can write to the CORB without over-running. The value read indicates the CORB Read Pointer offset in dword granularity. The offset entry read from this field has been successfully fetched by the DMA controller and may be over-written by software. This field may be read while the DMA engine is running.
Reserved	14:8	00h	Reserved. Software must do a read-modify-write to preserve the value of these bits.
CORB Read Pointer Reset	15	0b	Software writes a 1 to this bit to reset the CORB Read Pointer to 0 and clear any residual prefetched commands in the CORB hardware buffer within the controller. The hardware will physically update this bit to 1 when the CORB pointer reset is complete. Software must read a 1 to verify that the reset completed correctly. Software must clear this bit back to 0, by writing a 0, and then read back the 0 to verify that the clear completed correctly. The CORB DMA engine must be stopped prior to resetting the Read Pointer or else DMA transfer may be corrupted.

CORB Control – R/W – 8 bits – [Mem_Reg: Base + 4Ch]			
Field Name	Bits	Default	Description
CORB Memory Error Interrupt Enable	0	0b	If this bit is set, the controller will generate an interrupt if the Memory Error Interrupt bit is set.
Enable CORB DMA Engine	1	0b	0: DMA Stop 1: DMA Run After software writes a “0” to this bit, the hardware may not stop immediately. The hardware will physically update the bit to “0” when the DMA engine is truly stopped. Software must read a “0” from this bit to verify that the DMA engine is truly stopped.
Reserved	7:2	00h	Reserved. Software must do a read-modify-write to preserve the value of these bits.

CORB Status – R/W – 8 bits – [Mem_Reg: Base + 4Dh]			
Field Name	Bits	Default	Description
CORB Memory error Indication	0	0	If this status bit is set, the controller has detected an error in the pathway between the controller and memory. Writing a “1” to this bit will clear the bit, but a CRST must be performed before operation continues/
Reserved	7:2	0	Reserved. Software must use 0's for write to these bits.

CORB Size – R/W – 8 bits – [Mem_Reg: Base + 4Eh]			
Field Name	Bits	Default	Description
CORB Size	1:0	10b	These bits have no functional impact to the hardware. This HD Audio controller only supports 256 entries.
Reserved	3:2	00b	Reserved. Software must do a read-modify-write to preserve the value of these bits.
CORB Size Capability	7:4	0100b	Hardwired to 0100b indicating this controller only supports a CORB size of 256 entries.

RIRB Lower Base Address – RW – 32 bits – [Mem_Reg: Base + 50h]			
Field Name	Bits	Default	Description
RIRB Lower Base Address Unimplemented Bits	6:0	00h	Hardwired to 0. This forces 128-byte buffer alignment for cache line fetch optimizations.
RIRB Lower Base Address	31:7	0000000h	Upper 25 bits of the 32 bits Lower Base Address of the Response Input Ring Buffer, allowing the RIRB Base Address to be assigned on any 2 KB boundary. This register must not be written when the DMA engine is running or the DMA transfer may be corrupted.

RIRB Upper Address – RW – 32 bits – [Mem_Reg: Base + 54h]			
Field Name	Bits	Default	Description
RIRB Upper Base Address	31:0	00000000h	Upper 32 bits address of the RIRB. This register must not be written when the DMA engine is running or the DMA transfer may be corrupted.

RIRB Write Pointer – RW – 16 bits – [Mem_Reg: Base + 58h]			
Field Name	Bits	Default	Description
RIRB Write Pointer	7:0	00h	This field indicates the last valid RIRB entry written by the DMA controller. Software reads this field to determine how many responses it can read from the RIRB. The value read indicates the RIRB Write Pointer offset in two dwords since each RIRB entry is two dwords. This field may be read while the DMA engine is running.
Reserved	14:8	00h	Reserved. Software must do a read-modify-write to preserve the value of these bits.
RIRB Write Pointer Reset	15	0b	Software writes a “1” to this bit to reset the RIRB Write Pointer to 0’s. The DMA engine must be stopped prior to resetting the Write Pointer or else DMA transfer may be corrupted. This bit will always be read as 0.

RIRB Response Interrupt Count – R/W – 16 bits – [Mem_Reg: Base + 5Ah]			
Field Name	Bits	Default	Description
N Response Interrupt Count	7:0	00h	0x01: 1 Response sent to RIRB : 0xFF: 255 Responses sent to RIRB 0x00: 256 Responses sent to RIRB The DMA engine should be stopped when changing this field or else an interrupt may be lost. Note that each Response occupies two dwords in the RIRB. If more than one codec responds in one frame, then the count is increased by the number of responses received in the frame.
Reserved	15:8	00h	Reserved. Software must do a read-modify-write to preserve the value of these bits.

RIRB Control – R/W – 8 bits – [Mem_Reg: Base + 5Ch]			
Field Name	Bits	Default	Description
Response Interrupt Control	0	0b	0: Disable Interrupt 1: Generate an interrupt after N number of Responses are sent to the RIRB buffer or when an empty Response slot is encountered on all SDIN_x inputs after a frame which return a response (whichever occurs first). The N counter is reset when the interrupt is generated.
RIRB DMA Enable	1	0b	0: DMA Stop 1: DMA Run
Response Overrun Interrupt Control	2	0b	If this bit is set, the hardware will generate an interrupt when the Response Overrun Interrupt Status is set.
Reserved	15:3	0000h	Reserved. Software must do a read-modify-write to preserve the value of these bits.

RIRB Status – R/W – 8 bits – [Mem_Reg: Base + 5Dh]			
Field Name	Bits	Default	Description
Response Interrupt	0	0b	Hardware sets this bit to “1” when an interrupt has been generated after N number of Responses are sent to the RIRB buffer or when empty Response slot is encountered on all SDIN_x inputs (whichever occurs first). Software clears this bit by writing a “1” to this bit.
Reserved	2	0b	Reserved. Software must use 0's for write to these bits.
Response Overrun Interrupt Status	2	0b	Hardware sets this bit to a “1” when an overrun occurs in the RIRB. An interrupt may be generated if the Response Overrun Interrupt Control bit is set. Software clears this bit by writing a “1” to it.
Reserved	7:3	00h	Reserved. Software must use 0's for write to these bits.

RIRB Size – R/W – 8 bits – [Mem_Reg: Base + 5Eh]			
Field Name	Bits	Default	Description
RIRB Size	1:0	10b	These bits have no functional impact to the hardware. This HD Audio controller only supports 256 entries.
Reserved	3:2	00b	Reserved. Software must do a read-modify-write to preserve the value of these bits.
RIRB Size Capability	7:4	0100b	Hardwired to 0100b indicating this controller only supports a RIRB size of 256 entries.

Immediate Command Output Interface – R/W – 32 bits – [Mem_Reg: Base + 60h]			
Field Name	Bits	Default	Description
Immediate Command Write	31:0	00000000 h	The value written into this register is used as the verb to be sent out over the link when the ICB (Immediate Command Busy) bit is set to “1”. Software must ensure that the ICB bit is cleared before writing a value into this register or undefined behavior will result. Reads from this register will always return 0's.

Immediate Command Input Interface – R/W – 32 bits – [Mem_Reg: Base + 64h]			
Field Name	Bits	Default	Description
Immediate Response Read	31:0	00000000h	This register contains the value from the last response to come in over the link. If multiple codecs responded in the same frame, which one of the responses that will be saved is indeterminate.

Immediate Command Input Interface – R/W – 16 bits – [Mem_Reg: Base + 68h]			
Field Name	Bits	Default	Description
Immediate Command Status	0	0b	This bit is a 0 when the controller can accept an immediate command. Software must wait for this bit to be 0 before writing a value in the ICW register. This bit will be clear (indicating “ready”) when the following conditions are met: (1) the link is running, (2) the CORB is not active (CORBRP = CORBWP or CORBEN is not set), and (3) there is not an immediate command already in the queue waiting to be sent. Writing this bit to 1 will cause the contents of the ICW register to be sent as a verb in the next frame. Once a response is received the IRV bit will be set and this bit will be cleared indicating ready to transmit another verb.
Immediate Result Valid	1	0b	This bit is set to a 1 by hardware when a new response is latched into the IRR (Immediate Response Read) register. Software must clear this bit before issuing a new command by writing a one to it so that the software may determine when a new response has arrived.
Reserved	2	0b	Reserved. Software must use 0's for write to these bits.
Immediate Response Result Unsolicited	3	0b	Indicates whether the response latched in the Immediate Response Input Register is a solicited or unsolicited response.
Immediate Response Result Address	7:4	0h	The address of the codec which sent the response currently latched into the Immediate Response Input.
Reserved	15:8	00h	Reserved. Software must use 0's for write to these bits.

DMA Position Lower Base Address – R/W – 32 bits – [Mem_Reg: Base + 70h]			
Field Name	Bits	Default	Description
DMA Position Buffer Enable	0	0b	When this bit is set to a “1”, the controller will write the DMA positions of each of the DMA engines to the buffer in main memory periodically. Software can use this value to know what data in memory is valid data.
DMA Position Lower Base Address Unimplemented Bits	6:1	00h	Hardwired to 0. This forces 128-byte buffer alignment for cache line fetch optimizations.
DMA Position Lower Base Address	31:7	0000000h	Contains the upper 25 bits of the lower 32 bits of the DMA Position Buffer Base Address. This same address is used by the Flush Control, and must be programmed with a valid value before the Flush Control is initiated.

DMA Position Upper Base Address – R/W – 32 bits – [Mem_Reg: Base + 74h]			
Field Name	Bits	Default	Description
DMA Position Upper Base Address	31:0	00000000 h	Upper 32 bits of the DMA Position Buffer Base Address. This same address is used by the Flush Control, and must be programmed with a valid value before the Flush Control is initiated.

Stream Descriptor Control – R/W – 24 bits			
Input Stream 0 - [Mem_Reg: Base + 80h]			
Input Stream 1 - [Mem_Reg: Base + A0h]			
Input Stream 2 - [Mem_Reg: Base + C0h]			
Input Stream 3 - [Mem_Reg: Base + E0h]			
Output Stream 0 - [Mem_Reg: Base + 100h]			
Output Stream 1 - [Mem_Reg: Base + 120h]			
Output Stream 2 - [Mem_Reg: Base + 140h]			
Output Stream 3 - [Mem_Reg: Base + 160h]			
Field Name	Bits	Default	Description
Stream Reset	0	0b	Writing a “1” causes the corresponding stream to be reset. The Stream Descriptor registers (except this bit), FIFO’s and cadence generator for the corresponding stream are reset. After the stream hardware has completed sequencing into the reset state, it will report a “1” in this bit. Software must read a “1” from this bit to verify that the stream is in reset. Writing a “0” causes the corresponding stream to exit reset. When the stream hardware is ready to begin operation, it will report a “0” in this bit. Software must read a “0” from this bit before accessing any of the stream registers. The Run bit must be cleared before asserting SRST (Stream Reset).
Stream Run	1	0b	When set to “1”, the DMA engine associated with this input stream will be enabled to transfer data in the FIFO to main memory. When cleared to “0”, the DMA engine associated with this input stream will be disabled. If the corresponding SSYNC bit is “0”, input stream data will be taken from the link and moved to the FIFO and an over-run may occur.
Interrupt On Completion Enable	2	0b	Controls whether an interrupt is generated when the Buffer Completion Interrupt Status is set
FIFO Error Interrupt Enable	3	0b	Controls whether an interrupt is generated when the FIFO Error is set.
Descriptor Error Interrupt Enable	4	0b	Controls whether an interrupt is generated when the Descriptor Error Status is set.
Reserved	15:5	000h	Reserved. Software must do a read-modify-write to preserve the value of these bits.
Stripe Control	17:16	00b	The hardware only supports one SDO, this field has no functional impact.
Traffic Priority	18	0b	If set to “1”, it will cause the controller to generate non-snooped traffic.
Bidirectional Direction Control	19	0b	The hardware does not support bidirection, this field has no impact.
Stream Number	23:20	0h	The value reflects the Tag associated with the data being transferred on the link. When data controlled by this descriptor is sent out over the link, it will have this stream number encoded on the SYNC signal. When an input stream is detected on any of the SDIN_x signals that match this value, the data are loaded into the FIFO associated with this descriptor. 0000: Reserved 0001: Stream 1 : 1111: Stream 15

Stream Descriptor Status – R/W – 8 bits Input Stream 0 - [Mem_Reg: Base + 83h] Input Stream 1 - [Mem_Reg: Base + A3h] Input Stream 2 - [Mem_Reg: Base + C3h] Input Stream 3 - [Mem_Reg: Base + E3h] Output Stream 0 - [Mem_Reg: Base + 103h] Output Stream 1 - [Mem_Reg: Base + 123h] Output Stream 2 - [Mem_Reg: Base + 143h] Output Stream 3 - [Mem_Reg: Base + 163h]			
Field Name	Bits	Default	Description
Reserved	1:0	00b	Reserved. Software must use 0's for write to these bits.
Buffer Completion Interrupt Status	2	0b	For an Output Stream engine, this bit is set to "1" by the hardware after the last byte of data has been fetched from memory and put into DMA FIFO and the current descriptor has the IOC bit set. For an Input Stream engine, this bit is set to "1" by the hardware after the last byte of data has been removed from the DMA FIFO and the current descriptor has the IOC bit set. This bit is cleared by writing a "1" to this bit.
FIFO Error	3	0b	Set when a FIFO error occurs regardless of the FIFO Error Interrupt Enable bit. This bit is cleared by writing a "1" to this bit.
Descriptor Error	4	0b	During the fetch of a descriptor, an error has occurred.
FIFO Ready	5	0b	For an Output Stream, the controller hardware will set this bit to a "1" while the output DMA FIFO contains enough data to maintain the stream on the link.
Reserved	7:6	00b	Reserved. Software must use 0's for write to these bits.

Stream Descriptor Link Position in Buffer – R – 32 bits Input Stream 0 - [Mem_Reg: Base + 84h] Input Stream 1 - [Mem_Reg: Base + A4h] Input Stream 2 - [Mem_Reg: Base + C4h] Input Stream 3 - [Mem_Reg: Base + E4h] Output Stream 0 - [Mem_Reg: Base + 104h] Output Stream 1 - [Mem_Reg: Base + 124h] Output Stream 2 - [Mem_Reg: Base + 144h] Output Stream 3 - [Mem_Reg: Base + 164h]			
Field Name	Bits	Default	Description
Link Position in Buffer	31:0	00000000 h	This field indicates the number of bytes that have been received off the link.

Stream Descriptor Cyclic Buffer Length – R/W – 32 bits			
Input Stream 0 - [Mem_Reg: Base + 88h]			
Input Stream 1 - [Mem_Reg: Base + A8h]			
Input Stream 2 - [Mem_Reg: Base + C8h]			
Input Stream 3 - [Mem_Reg: Base + E8h]			
Output Stream 0 - [Mem_Reg: Base + 108h]			
Output Stream 1 - [Mem_Reg: Base + 128h]			
Output Stream 2 - [Mem_Reg: Base + 148h]			
Output Stream 3 - [Mem_Reg: Base + 168h]			
Field Name	Bits	Default	Description
Cyclic Buffer Length	31:0	00000000 h	Indicates the number of bytes in the complete cyclic buffer. Link Position in Buffer will be reset when it reaches this value. Software may only write to this register after Global Reset, Controller Reset, or Stream Reset has occurred. Once the Run bit has been set to enable the engine, software must not write to this register until after the next reset is asserted, or undefined events will occur.

Stream Descriptor Last Valid Index – R/W – 16 bits			
Input Stream 0 - [Mem_Reg: Base + 8Ch]			
Input Stream 1 - [Mem_Reg: Base + ACh]			
Input Stream 2 - [Mem_Reg: Base + CCh]			
Input Stream 3 - [Mem_Reg: Base + ECh]			
Output Stream 0 - [Mem_Reg: Base + 10Ch]			
Output Stream 1 - [Mem_Reg: Base + 12Ch]			
Output Stream 2 - [Mem_Reg: Base + 14Ch]			
Output Stream 3 - [Mem_Reg: Base + 16Ch]			
Field Name	Bits	Default	Description
Last Valid Index	7:0	00h	The value written to this register indicates the index for the last valid Buffer Descriptor in BDL. After the controller has processed this descriptor, it will wrap back to the first descriptor in the list and continue processing. LVI (Last Valid Index) must be "1"; i.e., there must be at least two valid entries in the BDL before DMA operations can begin. This value should not be modified except when the Run bit is "0".
Reserved	15:8	00h	Reserved. Software must do a read-modify-write to preserve the value of these bits.

Stream Descriptor FIFO Size – R – 16 bits			
Input Stream 0 - [Mem_Reg: Base + 90h]			
Input Stream 1 - [Mem_Reg: Base + B0h]			
Input Stream 2 - [Mem_Reg: Base + D0h]			
Input Stream 3 - [Mem_Reg: Base + F0h]			
Output Stream 0 - [Mem_Reg: Base + 110h]			
Output Stream 1 - [Mem_Reg: Base + 130h]			
Output Stream 2 - [Mem_Reg: Base + 150h]			
Output Stream 3 - [Mem_Reg: Base + 170h]			
Field Name	Bits	Default	Description
FIFO Size	15:0	00h	For Output Stream, the FIFO Size varies between 32 dwords to 256 dwords depending on the Stream Format. For Input Stream, the FIFO Size is fixed at 64 dwords.

Stream Descriptor Format – R/W – 16 bits			
Input Stream 0 - [Mem_Reg: Base + 92h]			
Input Stream 1 - [Mem_Reg: Base + B2h]			
Input Stream 2 - [Mem_Reg: Base + D2h]			
Input Stream 3 - [Mem_Reg: Base + F2h]			
Output Stream 0 - [Mem_Reg: Base + 112h]			
Output Stream 1 - [Mem_Reg: Base + 132h]			
Output Stream 2 - [Mem_Reg: Base + 152h]			
Output Stream 3 - [Mem_Reg: Base + 172h]			
Field Name	Bits	Default	Description
Number of Channels	3:0	0h	Number of channels in each frame of the stream. 0000: 1 0001: 2 : 1111: 16
Bits per Sample	6:4	0h	000: 8 bits 001: 16 bits 010: 20 bits 011: 24 bits 100: 32 bits 101 – 111: Reserved
Reserved	7	0b	Reserved. Software must do a read-modify-write to preserve the value of these bits.
Sample Base Rate Divisor	10:8	000b	000: Divide by 1 (48 kHz, 44.1 kHz) 001: Divide by 2 (24 kHz, 22.05 kHz) 010: Divide by 3 (16 kHz, 32 kHz) 011: Divide by 4 (11.025 kHz) 100: Divide by 5 (9.6 kHz) 101: Divide by 6 (8 kHz) 110: Divide by 7 111: Divide by 8 (6 kHz)
Sample Base Rate Multiple	13:11	000b	000: x1 (48 kHz, 44.1 kHz) 001: x2 (96 kHz, 88.2 kHz, 32 kHz) 010: x3 (144 kHz) 011: x4 (192 kHz, 176.4 kHz) 101 – 111: Reserved
Sample Base Rate	14	0b	0: 48 kHz 1: 44.1 kHz
Reserved	15	0b	Reserved

Stream Descriptor BDL Pointer Lower Base Address – R/W – 32 bits			
Input Stream 0 - [Mem_Reg: Base + 98h]			
Input Stream 1 - [Mem_Reg: Base + B8h]			
Input Stream 2 - [Mem_Reg: Base + D8h]			
Input Stream 3 - [Mem_Reg: Base + F8h]			
Output Stream 0 - [Mem_Reg: Base + 138h]			
Output Stream 2 - [Mem_Reg: Base + 158h]			
Output Stream 3 - [Mem_Reg: Base + 178h]			
Field Name	Bits	Default	Description
Reserved	6:0	00h	Hardwired to 0's to force 128 byte alignment of the BDL.
Buffer Descriptor List Lower Base Address	31:7	0000000h	Upper 25 bits of the lower 32 bit address of the Buffer Descriptor List. This value should not be modified except when the Run bit is "0".

Stream Descriptor BDL Pointer Upper Base Address – R/W – 32 bits			
Input Stream 0 - [Mem_Reg: Base + 9Ch]			
Input Stream 1 - [Mem_Reg: Base + BCh]			
Input Stream 2 - [Mem_Reg: Base + DCh]			
Input Stream 3 - [Mem_Reg: Base + FCh]			
Output Stream 0 - [Mem_Reg: Base + 11Ch]			
Output Stream 1 - [Mem_Reg: Base + 13Ch]			
Output Stream 2 - [Mem_Reg: Base + 15Ch]			
Output Stream 3 - [Mem_Reg: Base + 17Ch]			
Field Name	Bits	Default	Description
Buffer Descriptor List Upper Base Address	31:0	00000000h	Upper 32 bit address of the Buffer Descriptor List. This value should not be modified except when the Run bit is "0".

Wall Clock Counter Alias – R – 32 bits – [Mem_Reg: Base + 2030h]			
Field Name	Bits	Default	Description
Wall Clock Counter Alias	31:0	00000000h	An alias of the Wall Clock Counter register at offset 0x30. It behaves exactly the same as if the Wall Clock Counter register were being read directly.

Stream Descriptor Link Position in Buffer Alias – R – 32 bits			
Input Stream 0 - [Mem_Reg: Base + 2084h]			
Input Stream 1 - [Mem_Reg: Base + 20A4h]			
Input Stream 2 - [Mem_Reg: Base + 20C4h]			
Input Stream 3 - [Mem_Reg: Base + 20E4h]			
Output Stream 0 - [Mem_Reg: Base + 2104h]			
Output Stream 1 - [Mem_Reg: Base + 2124h]			
Output Stream 2 - [Mem_Reg: Base + 2144h]			
Output Stream 3 - [Mem_Reg: Base + 2164h]			
Field Name	Bits	Default	Description
Link Position in Buffer Alias	31:0	00000000h	An alias of the Link Position in Buffer register of each Stream Descriptor.

3 Register Descriptions: PCI Bridges

3.1 LPC ISA Bridge (Device 20, Function 3)

LPC controller registers are supported in PCI configuration and I/O space. These registers are cleared by the PCIRST# signal; therefore, they will be cleared on a warm boot.

Note: Some LPC functions are controlled by, and associated with, certain PCI configuration registers in the SMBus/ACPI device. For more information refer to [section 2.4: SMBus Module and ACPI Block \(Device 20, Function 0\)](#). The diagram below lists these LPC functions and the associated registers.

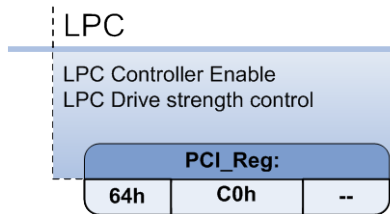

3.1.1 Programming Interface

- Write LPC_enable bit in function 0, register 64, bit 20.
- Enable LPC address decode ranges.
- Program DMA controller for any bus master or DMA cycles.
- Perform LPC cycles from PCI or DMA requests from LPC agent.

3.1.2 PCI Configuration Registers

The LPC host controller supports a set of configuration register required by the PCI specification.

Registers not listed here will have this default behavior: read from the register returns 0's; write to the register is ignored.

Register Name	Offset Address
VID	00h
DID	02h
CMD	04h
STATUS	06h
Revision ID/Class Code	08h
Cache Line Size	0Ch
Latency Timer	0Dh
Header Type	0Eh
BIST	0Fh
Base Address Reg 0	10h
Subsystem ID & Subsystem Vendor ID	2Ch
Capabilities Pointer	34h
PCI Control	40h
IO Port Decode Enable Register 1	44h
IO Port Decode Enable Register 2	45h
IO Port Decode Enable Register 3	46h
IO Port Decode Enable Register 4	47h
IO/Mem Port Decode Enable Register 5	48h
LPC Sync Timeout Count	49h
IO/Mem Port Decode Enable Register 6	4Ah
Memory Range Register	4Ch

Register Name	Offset Address
Rom Protect 0	50h
Rom Protect 1	54h
Rom Protect 2	58h
Rom Protect 3	5Ch
PCI Memory Start Address for LPC Target Cycles	60h
PCI Memory End Address for LPC Target Cycles	62h
PCI IO base Address for Wide Generic Port	64h
LPC ROM Address Range 1 (Start Address)	68h
LPC ROM Address Range 1 (End Address)	6Ah
LPC ROM Address Range 2 (Start Address)	6Ch
LPC ROM Address Range 2 (End Address)	6Eh
Firmware Hub Select	70h
Alternative Wide Io Range Enable	74h
Reserved	78h
TPM register	7Ch
LPCCLKCntl register	7Dh
MSI Capability register	80h
TMKBC_BaseAddrLow	84h
TMKBC_BaseAddrHigh	88h
TMKBC_Remap	8Ch
Wide_IO2	90h
ImcGpioCntrl	92h
IMCaCntrl	94h
IMCbCntrl	96h
HostOwnLPC	98h
ImcOwnLPC	99h
reserved	9Ch
SPI Base_Addr	A0h
IMC_PortAddress	A4h
RomDmaSrcAddr	B0h
RomDmaTargetAddr	B4h
RomDmaControl	B8h
ImcControl	BAh
HostControl	BBh
ImcInstrRomPage	BCh
ImcInstrMemPage	BEh
ImcRomFlashPage	C0h
ImcLpcMemPage	C2h
ImcDataPage	C4h
ImcGpio_Out	C6h
ImcGpio_OeB	C8h
ImcGpioStatus	CAh
ImcGpio_PDControl	CCh
ImcGpio_PUControl	CEh
IMCa_Out	D0h
IMCa_OeB	D1h
IMCa_Status	D2h
IMCa_PDControl	D3h
IMCa_PUControl	D4h
IMCb_Out	D5h
IMCb_OeB	D7h
IMCb_Status	D9h
IMCb_PDControl	DBh
IMCb_PUControl	DDh
IMC_Misc1	DFh

Note: PCI function 3 configuration registers are described below.

VID- R - 16 bits - [PCI_Reg: 00h]			
Field Name	Bits	Default	Description
Vendor ID	15:0	1002h	Vendor ID
Vendor ID Register: This register holds a unique 16-bit value assigned to a vendor, and combined with the device ID it identifies any PCI device.			

DID- R - 16 bits - [PCI_Reg: 02h]			
Field Name	Bits	Default	Description
Devide ID	15:0	439Dh	Device ID
Device ID Register: This register holds a unique 16-bit value assigned to a device and together with the vendor ID, it identifies any PCI device.			

CMD- RW - 16 bits - [PCI_Reg: 04h]			
Field Name	Bits	Default	Description
IO Space	0	1b	I/O Access Enable. This bit controls access to the I/O space registers. When this bit is 1, it enables access to Legacy IDE ports, and PCI bus master IDE I/O registers are enabled.
Memory Space	1	1b	Memory Access Enable. This function is not implemented. This bit is always 0.
Bus Master	2	1b	Master Enable. Bus master function enable. 1: Enable 0: Disable.
Special Cycles	3	1b	Special Cycle recognition enable. This feature is not implemented and this bit is always 0.
Memory Write and Invalidate Enable	4	0b	Memory Write and Invalidate Enable. Not implemented. This bit is always 0.
VGA Palette Snoop	5	0b	VGA Palette Snoop Enable- The SP5100 does not need to snoop VGA palette cycles. This bit is always 0.
Parity Error Response	6	0b	PERR# (Response) Detection Enable bit - If set to 1, the SP5100 asserts PERR# when it is the agent receiving data AND it detects a parity error. PERR# is not asserted if this bit is 0.
Stepping Control	7	0b	Wait Cycle enable -The SP5100 does not need to insert a wait state between the address and data on the AD lines. This bit is always 0.
SERR# Enable	8	0b	SERR# enable - If set to 1, the SP5100 asserts SERR# when it detects as address parity error. SERR# is not asserted if this bit is 0.
Fast Back-to-Back Enable	9	0b	Fast Back-to-back enable. The SP5100 only acts as a master to a single device, so this functionality is not needed. This bit is always 0.
Reserved	15:10	00h	
Command Register: The PCI specification defines this register to control a PCI device's ability to generate and respond to PCI cycles. Writes to this register except bit 6, have no effect. Bit[3:0]=0fh and read only			

STATUS- RW - 16 bits - [PCI_Reg: 06h]			
Field Name	Bits	Default	Description
Reserved	3:0	0h	
Capabilities List	4	0b	This bit is read only. When reg0x78[1] is 1, this bit reads 1; when reg0x78[1] is 0, this bit reads 0.
Reserved	7:5	0h	
Master Data Parity Error	8	0h	Data Parity reported. Set to 1 if the SP5100 detects PERR# asserted while acting as PCI master (whether PERR# was driven by the SP5100 or not.)

STATUS- RW - 16 bits - [PCI_Reg: 06h]			
Field Name	Bits	Default	Description
Device Select Timing	10:9	1h	DEVSEL# timing. Read only bits indicating DEVSEL# timing when performing a positive decode. Since DEVSEL# is asserted to meet the medium timing, these bits are encoded as 01b.
Signaled Target Abort	11	0b	Signaled Target Abort. This bit is set to 1 when the SB400 signals Target Abort.
Received Target Abort	12	0b	Received Target Abort. This bit is set to 1 when an SB400-generated PCI cycle (the SB400 is the PCI master) is aborted by a PCI target. Cleared by writing a 1 to it.
Received Master Abort	13	0b	Received Master Abort Status. Set to 1 when the SP5100 acts as a PCI master and aborts a PCI bus memory cycle. Cleared by writing a 1 to this bit.
Signaled System Error	14	0b	SERR# status. This bit is set to 1, when the SP5100 detects a PCI address parity error.
Detected Parity Error	15	0b	Detected Parity Error. This bit is set to 1 when the SP5100 detects a parity error.
Status Register: The PCI specification defines this register to record status information for PCI related events. This is a read/write register. However, writes can only reset bits. A bit is reset when the register is written and the data in the corresponding bit location is a 1.			

Revision ID/Class Code - R - 8 bits - [PCI_Reg: 08h]			
Field Name	Bits	Default	Description
Revision ID	7:0	00h	These bits are hardwired to 00h to indicate the revision level of the chip design
Class Code	31:8	060100h	Class Code.
Revision ID/Class Code Register: This read only register contains the device's revision information and generic function. Since SB400 is an ISA bridge, its assigned class code is 060100h.			

Cache Line Size - R - 8 bits - [PCI_Reg: 0Ch]			
Field Name	Bits	Default	Description
Cache Line Size	7:0	00h	Cache Line Size.
Cache Line Size Register: This register specifies the system cache line size. This register is not implemented.			

Latency Timer - R - 8 bits - [PCI_Reg: 0Dh]			
Field Name	Bits	Default	Description
Latency Timer	7:0	00h	Latency Timer.
Latency Timer Register: This register specifies the value of the Latency Timer in units of PCICLKs.			

Header Type - R - 8 bits - [PCI_Reg: 0Eh]			
Field Name	Bits	Default	Description
Header Type	7:0	80h	Header Type.
Header Type Register: This register identifies the type of the predefined header in the configuration space. Since THE SB400 is a multifunction device, the most significant bit is set.			

BIST- R - 8 bits - [PCI_Reg: 0Fh]			
Field Name	Bits	Default	Description
BIST	7:0	00h	BIST.
Built-in Self Test Register: This register is used for control and status for Built-in Self Test. LPC has no BIST modes.			

Base Address Reg 0- RW* - 32 bits - [PCI_Reg: 10h]			
Field Name	Bits	Default	Description
Base Address 0	31:0	0000_0000h	Base address register 0.

Subsystem ID & Subsystem Vendor ID - Wo/Ro - 32 bits - [PCI_Reg: 2Ch]			
Field Name	Bits	Default	Description
Subsystem Vendor ID	15:0	0000h	Subsystem Vendor ID (write once)
Subsystem ID	31:16	0000h	Subsystem ID (write once)
This 4-byte register is a write-once & read-only afterward register. The BIOS writes this register once (all 4 bytes at once) and software reads its value (when needed).			

Capabilities Pointer - Ro - 32 bits - [PCI_Reg: 34h]			
Field Name	Bits	Default	Description
Capabilities Pointer	7:0	00h	When reg0x78[1] (msi on) is 0, this field reads 0; when reg0x78[1] is 1, this field reads 80h, pointing to the starting address of MSI capability register
Reserved	31:8	000000h	

PCI Control - RW - 8 bits - [PCI_Reg: 40h]			
Field Name	Bits	Default	Description
Reserved	1:0	0h	
Legacy DMA Enable	2	0b	Setting it to 1 enables lpc dma cycle. Note: 32-bit DMA is not supported. Transfer size: Channels 0-3: 8 bits, channels 5-7: 16 bits.
Reserved	4:3	0h	
BiosSemaphore	5	0b	This bit is writeable by the BIOS and read by the integrated micro-controller (IMC). This is used as the software semaphore mechanism between the BIOS and IMC to see which can access the common resource. The BIOS should read bit [6] first to see if IMC has taken ownership of the resource first. If bit [6] is 0, then the BIOS should write 1 to this bit and then follow by a read to see if this bit is set. If this bit is set, it means that the BIOS has successfully taken the ownership of the resource. If this bit returns 0 and bit [6] returns 1, then IMC has taken the ownership first. Software should always clear this bit after it has completed its access to the resource.
ImcSemaphore	6	0b	This bit is writeable by the integrated micro-controller (IMC) and read by the BIOS. This is used as the software semaphore mechanism between the BIOS and IMC to see which can access the common resource. IMC should read bit [5] first to see if the BIOS has taken ownership of the resource first. If bit [5] is 0, then IMC should write 1 to this bit and then follow by a read to see if this bit is set. If this bit is set, it means IMC has successfully taken the ownership of the resource. If this bit returns 0 and bit [5] returns 1, then the BIOS has taken the ownership first. IMC should always clear this bit after it has completed its access to the resource.
IntegratedImcPresent	7	0b	This bit is written by the integrated IMC to indicate it is presented within the SC

IO Port Decode Enable Register 1- RW - 8 bits - [PCI_Reg: 44h]			
Field Name	Bits	Default	Description
Parallel Port Enable 0	0	0b	Port enable for parallel port, 378-37fh
Parallel Port Enable 1	1	0b	Port enable for parallel port, 778-77fh
Parallel Port Enable 2	2	0b	Port enable for parallel port, 278-27fh
Parallel Port Enable 3	3	0b	Port enable for parallel port, 678-67fh
Parallel Port Enable 4	4	0b	Port enable for parallel port, 3bc-3bfh
Parallel Port Enable 5	5	0b	Port enable for parallel port, 7bc-7bfh

IO Port Decode Enable Register 1- RW - 8 bits - [PCI_Reg: 44h]			
Field Name	Bits	Default	Description
Serial Port Enable 0	6	0b	Port enable for serial port, 3f8-3ffh
Serial Port Enable 1	7	0b	Port enable for serial port, 2f8-2ffh
This register controls the decoding of parallel & serial ports. Writing '1' to a bit enables the corresponding IO range.			

IO Port Decode Enable Register 2- RW - 8 bits - [PCI_Reg: 45h]			
Field Name	Bits	Default	Description
Serial Port Enable 2	0	0b	Port enable for serial port, 220-227h
Serial Port Enable 3	1	0b	Port enable for serial port, 228-22fh
Serial Port Enable 4	2	0b	Port enable for serial port, 238-23fh
Serial Port Enable 5	3	0b	Port enable for serial port, 2e8-2efh
Serial Port Enable 6	4	0b	Port enable for serial port, 338-33fh
Serial Port Enable 7	5	0b	Port enable for serial port, 3e8-3efh
Audio Port Enable 0	6	0b	Port enable for audio port, 230-233h (Range 220-22fh needs to be enabled using bits 0 and 1)
Audio Port Enable 1	7	0b	Port enable for audio port, 240-253h
This register controls the decoding of serial & audio ports. Writing '1' to a bit enables the corresponding IO range.			

IO Port Decode Enable Register 3- RW - 8 bits - [PCI_Reg: 46h]			
Field Name	Bits	Default	Description
Audio Port Enable 2	0	0b	Port enable for audio port, 260-273h
Audio Port Enable 3	1	0b	Port enable for audio port, 280-293h
MIDI Port Enable 0	2	0b	Port enable for MIDI port, 300-301h
MIDI Port Enable 1	3	0b	Port enable for MIDI port, 310-311h
MIDI Port Enable 2	4	0b	Port enable for MIDI port, 320-321h
MIDI Port Enable 3	5	0b	Port enable for MIDI port, 330-331h
MSS Port Enable 0	6	0b	Port enable for MSS port, 530-537h
MSS Port Enable 1	7	0b	Port enable for MSS port, 604-60bh
This register controls the decoding of audio, MIDI, & MSS ports. Writing '1' to a bit enables the corresponding IO range.			

IO Port Decode Enable Register 4- RW - 8 bits - [PCI_Reg: 47h]			
Field Name	Bits	Default	Description
MSS Port Enable 2	0	0b	Port enable for MSS port, e80-e87h
MSS Port Enable 3	1	0b	Port enable for MSS port, f40-f47h
FDC Port Enable 0	2	0b	Port enable for FDC port, 3f0-3f7h
FDC Port Enable 1	3	0b	Port enable for FDC port, 370-377h
Game Port Enable	4	0b	Port enable for Game port, 200-20fh
KBC Port Enable	5	0b	Port enable for KBC port, 60 & 64h
ACPI Micro-Controller Port Enable	6	0b	Port enable for ACPI Micro-Controller port, 62 & 66h
Ad-Lib Port Enable	7	0b	Port enable for Ad-Lib port, 388-389h
This register controls the decoding of MSS, FDC, game, KBC, ACPI micro-controller, & Ad-lib ports. Writing '1' to a bit enables the corresponding IO range.			

IO/Mem Port Decode Enable Register 5- RW - 8 bits - [PCI_Reg: 48h]			
Field Name	Bits	Default	Description
Super IO Configuration Port Enable	0	0b	Port enable for Super IO config port, 2e-2fh
Alternate Super IO Configuration Port Enable	1	0b	Port enable for Alternate super IO config port, 4e-4fh
Wide Generic IO Port Enable	2	0b	Port enable for wide generic port, see register 64-65h

IO/Mem Port Decode Enable Register 5- RW - 8 bits - [PCI_Reg: 48h]			
Field Name	Bits	Default	Description
Rom Range 1 Port Enable	3	0b	Port enable for LPC ROM address range 1 (memory), see register 68-6bh
Rom Rnange 2 Port Enable	4	0b	Port enable for LPC ROM address range 2 (memory), see register 6c-6fh
Memory Range Port Enable	5	0b	Port enable for LPC memory target range, see register 60-63h
RTC IO Range Port Enable	6	0b	Port enable for RTC I/O range 70h~73h
Sync Timeout Counter Enable	7	0b	LPC sync timeout counter enabled when set to '1', otherwise the counter is disabled. This counter is used to avoid a deadlock condition if an LPC device drives sync forever. Timeout count is programmed in register 49h. Write '0' to this bit if an LPC device is extremely slow & takes more than 255 LPC clocks to complete a cycle.
This register controls the decoding of Super IO configuration, alternate super-IO configuration, wide generic ports, ROM1 & ROM2 ports, and memory port. Writing '1' to a bit enables the corresponding IO/ROM/Memory range. Bit 7 controls enable/disable of LPC sync timeout counter.			

LPC Sync Timeout Count - RW - 8 bits - [PCI_Reg: 49h]			
Field Name	Bits	Default	Description
Sync Timeout Count	7:0	FFh	Sync Timeout Count.
This register contains the value of LPC sync timeout count. This is the number of LPC clocks the state machine will wait when LPC data = sync before aborting the cycle (when timeout counter is enabled; see register 48, bit 7).			

IO/Mem Port Decode Enable Register 6- RW - 8 bits - [PCI_Reg: 4Ah]			
Field Name	Bits	Default	Description
IO port enable 0	0	0b	Port enable for IO port 400h-43Fh
IO port enable 1	1	0b	Port enable for IO port 480h-4BFh
IO port enable 2	2	0b	Port enable for IO port 500h-53Fh
IO port enable 3	3	0b	Port enable for IO port 580h-5BFh
Mem port enable	4	0b	Port enable for 4K byte memory range defined in reg0x4C
IO port enable 4	5	0b	Port enable for IO port 80h
IO port enable 5	6	0b	Port enable for IO port 4700h-470Bh
IO port enable 6	7	0b	Port enable for IO port FD60h-FD6Fh

IO/Mem Port Decode Enable Register 7- RW - 8 bits - [PCI_Reg: 4Bh]			
Field Name	Bits	Default	Description
Wide_io1_enable	0	0b	Wide io port 1 (defined in register 66/67h) enable
Wide_io2_enable	0	0b	Wide io port 2 (defined in register 90/91h) enable
Reserved	0	0b	

Memory Range Register - RW - 32 bits - [PCI_Reg: 4Ch]			
Field Name	Bits	Default	Description
Reserved	11:0	0	
Base Address	31:12	0	This register defines a 4K byte memory range from {Base Address, 000h} to {Base Address, fffh}. The range is enabled by reg0x4A[4].

Rom Protect 0 - RW - 32 bits - [PCI_Reg: 50h]			
Field Name	Bits	Default	Description
Write Protect	0	0b	When this bit is set, the memory range defined by this register is write-protected. Writing to the range has no effect.
Read Protect	1	0b	When this bit is set, the memory range defined by this register is read-protected. Reading any location in the range returns FFFF_FFFFh.
Rom Offset	10:2	000h	Rom range offset
Rom Base	31:11	000000h	Rom Base and Rom Offset together define the ROM range to be protected. The range is: From {Rom Base, 000_0000_0000b} to {Rom Base, 000_0000_0000b} + {0_0000_0000_0000b, Rom Offset, 11_1111_1111b}
For Host, this register is write/read, but it can only be written once after hardware reset. Subsequent writes to it have no effect. For IMC, this register is always write/read.			

Rom Protect 1 - RW - 32 bits - [PCI_Reg: 54h]			
Field Name	Bits	Default	Description
This register has exactly the same definition as that of Rom Protect 0.			

Rom Protect 2 - RW - 32 bits - [PCI_Reg: 58h]			
Field Name	Bits	Default	Description
This register has exactly the same definition as that of Rom Protect 0.			

Rom Protect 3 - RW - 32 bits - [PCI_Reg: 5Ch]			
Field Name	Bits	Default	Description
This register has exactly the same definition as that of Rom Protect 0.			

PCI Memory Start Address for LPC Target Cycles - RW - 16 bits - [PCI_Reg: 60h]			
Field Name	Bits	Default	Description
Memory Start Address	15:0	0000h	16-bit starting address of the LPC target (memory) range.
This register contains upper 16-bits of the starting address of the LPC memory target range. The lower 16-bits of the starting address are considered 0's. This range can be enabled/disabled using register 48h, bit 5.			

PCI Memory End Address for LPC Target Cycles - RW - 16 bits - [PCI_Reg: 62h]			
Field Name	Bits	Default	Description
Memory End Address	15:0	0000h	16-bit END address of the LPC target (memory) range.
This register contains upper 16-bits of the ending address of the LPC memory target range. The lower 16-bits of the end address are considered 1's. This range can be enabled/disabled using register 48h, bit 5.			

PCI IO base Address for Wide Generic Port - RW - 16 bits - [PCI_Reg: 64h]			
Field Name	Bits	Default	Description
IO Base Address 0	15:0	0000h	16-bit PCI IO base address for wide generic port range. 512 byte wide range. This function is enabled by PCI register 48h, bit 2
IO Base Address 1	31:16	0000h	16-bit PCI IO base address for wide generic port range. 512 byte wide range. This function is enabled by PCI register 4Bh, bit 0
This register contains two 16-bits of IO base address for LPC IO (wide generic port) target range. The limit address is found by adding 512 to the base address.			

LPC ROM Address Range 1 (Start Address) - RW - 16 bits - [PCI_Reg: 68h]			
Field Name	Bits	Default	Description
Rom Start Address 1	15:0	08h (if iLpc_Rom strap is enabled), 00h (if the strap is disabled)	16-bit starting address of the LPC ROM (memory) address range 1. Default is set to 512K below 1M
This register contains upper 16-bits of the starting address of the LPC ROM address range 1. The lower 16-bits of the starting address are considered 0's. This range can be enabled/disabled using register 48h, bit 3 or when strap pins are set to choose LPC ROM.			

LPC ROM Address Range 1 (End Address) - RW - 16 bits - [PCI_Reg: 6Ah]			
Field Name	Bits	Default	Description
Rom End Address 1	15:0	0fh (if iLpc_Rom strap is enabled), 00h (if the strap is disabled)	16-bit END address of the LPC ROM (memory) address range 1.
This register contains upper 16-bits of the ending address of the LPC ROM address range 1. The lower 16-bits of the end address are considered 1's. This range can be enabled/disabled using register 48h, bit 3 or when strap pins are set to choose LPC ROM.			

LPC ROM Address Range 2 (Start Address)- RW - 16 bits - [PCI_Reg: 6Ch]			
Field Name	Bits	Default	Description
Rom Start Address 2	15:0	FFF8h (if iLpc_Rom strap is enabled), 00h (if the strap is disabled)	16-bit starting address of the LPC ROM (memory) address range 2. Default is set to 512K below 4GB
This register contains upper 16-bits of the starting address of the LPC ROM address range 2. The lower 16-bits of the starting address are considered 0's. This range can be enabled/disabled using register 48h, bit 4 or when strap pins are set to choose LPC ROM.			

LPC ROM Address Range 2 (End Address) - RW - 16 bits - [PCI_Reg: 6Eh]			
Field Name	Bits	Default	Description
Rom End Address 2	15:0	FFFFh (if iLpc_Rom strap is enabled), 00h (if the strap is disabled)	16-bit END address of the LPC ROM (memory) address range 2.
This register contains upper 16-bits of the ending address of the LPC ROM address range 2. The lower 16-bits of the end address are considered 1's. This range can be enabled/disabled using register 48h, bit 4 or when strap pins are set to choose LPC ROM.			

Firmware Hub Select – RW* - 32 bits - [PCI_Reg: 70h]			
Field Name	Bits	Default	Description
FWH_C0_IDSEL	3:0	7h	IDSEL for two 512 KB FWH memory ranges. The IDSEL programmed in this field addresses the following memory ranges: FFC0 0000h-FFC7 FFFFh FF80 0000h-FF87 FFFFh
FWH_C8_IDSEL	7:4	6h	IDSEL for two 512 KB FWH memory ranges. The IDSEL programmed in this field addresses the following memory ranges: FFC8 0000h-FFCF FFFFh FF88 0000h-FF8F FFFFh
FWH_D0_IDSEL	11:8	5h	IDSEL for two 512 KB FWH memory ranges. The IDSEL programmed in this field addresses the following memory ranges: FFD0 0000h-FFD7 FFFFh FF90 0000h-FF97 FFFFh

Firmware Hub Select – RW* - 32 bits - [PCI_Reg: 70h]			
Field Name	Bits	Default	Description
FWH_D8_IDSEL	15:12	4h	IDSEL for two 512 KB FWH memory ranges. The IDSEL programmed in this field addresses the following memory ranges: FFD8 0000h-FFDF FFFFh FF98 0000h-FF9F FFFFh
FWH_E0_IDSEL	19:16	3h	IDSEL for two 512 KB FWH memory ranges. The IDSEL programmed in this field addresses the following memory ranges: FFE0 0000h-FFE7 FFFFh FFA0 0000h-FFA7 FFFFh
FWH_E8_IDSEL	23:20	2h	IDSEL for two 512 KB FWH memory ranges. The IDSEL programmed in this field addresses the following memory ranges: FFE8 0000h-FFE7 FFFFh FFA8 0000h-FFAF FFFFh
FWH_F0_IDSEL	27:24	0h	IDSEL for two 512 KB FWH memory ranges. The IDSEL programmed in this field addresses the following memory ranges: FFF0 0000h-FFF7 FFFFh FFB0 0000h-FFB7 FFFFh
FWH_F8_IDSEL	31:28	0h	IDSEL for two 512 KB FWH memory ranges and one 128KB memory range. This field is fixed at 0000. The IDSEL in this field addresses the following memory ranges: FFF8 0000h-FFFF FFFFh FFB8 0000h-FFBF FFFFh 000E 0000h-000F FFFFh
<p>This register is used to generate the 4-bit IDSEL phase when LPC does read/write to firmware hub memory on LPC bus. If PCI address falls in certain range, the 4-bit value in the register for that range is used as IDSEL. Every firmware hub memory on LPC bus has 4 strap pins. If value on those pins matches IDSEL from LPC host, the memory is selected.</p> <p>Bit [31:28] read only Bit[27:24] is read only when IMC strap pin is on. Default Value: 00234567h</p>			

Alternative Wide IO Range Enable- W/R - 32 bits - [PCI_Reg: 74h]			
Field Name	Bits	Default	Description
Alternative Wide Io Range Enable	0	0b	Wide IO range is usually 512 bytes. With this bit set, the range changes to 16 bytes only. To use this feature, address in reg0x64~65 must be aligned to 16 bytes, i.e., bit[3:0] must be 0. If the address is not aligned to 16bytes, the IO range is from address[15:0] to {address[15:4],0xF}.
Reserved	1	0b	
Alternative Wide Io 1 Range Enable	2	0b	Similar to bit 0, but it applies to io address defined in reg0x66~67.
Alternative Wide Io 2 Range Enable	3	0b	Similar to bit 0, but it applies to io address defined in reg0x90~91.
Reserved	7:4	00h	

Miscellaneous Control Bits- W/R - 8 bits - [PCI_Reg: 78h]			
Field Name	Bits	Default	Description
FlowCtrlEn	0	1b	1: Request from host has the equal priority as other requesters. 0: Always service the request from Host whenever there is a request from Host pending.

Miscellaneous Control Bits- W/R - 8 bits - [PCI_Reg: 78h]			
Field Name	Bits	Default	Description
Msi On	1	0b	When this bit is set to 1, it turns on LPC MSI capability. The following will be true: * Reg0x04[20] (capabilities list) reads 1. * Reg0x34[7:0] (capabilities pointer) reads 80h When this bit is set to 0, it turns off lpc MSI capability. The following will be true: * Reg0x04[20] reads 0. * Reg0x34[7:0] reads 0.
LDRQ0	2	1b	Enables LDRQ0# on LPC bus if set to 1
LDRQ1	3	1b	Enables LDRQ1# on LPC bus if set to 1
SMMWriteRomEn	4	1b	Enables Rom access in SMM mode. This is to allow BIOS to override the write protect bits
Reserved	31:4	00000_000h	

TPM (trusted plant form module) register- W/R - 8 bits - [PCI_Reg: 7Ch]			
Field Name	Bits	Default	Description
Tpm12_en	0	0b	When set to 1, it enables decoding of tpm (trusted platform module) cycles defined in TPM1.2 spec (Refer to the addresses defined in bit[1] below). Note that tpm12_en and tpm_legacy are independent bits; they respectively turn on decoding of different tpm addresses.
Tpm_amd	1	0b	This bit is replaced with strap pin K8system (to support amd K8 CPU), and no longer in use. It is read only and returns 0. When the strap is 0, it ONLY supports these normal tpm cycles. Here are the cycle defintion. (Left hand side is system/software memory address, which is translated to LPC IO address on the right hand side.) 0xFED4_0xxx --> 0x0xxx 0xFED4_1xxx --> 0x1xxx 0xFED4_2xxx --> 0x2xxx 0xFED4_3xxx --> 0x3xxx 0xFED4_4xxx --> 0x4xxx When the strap is 1, it ONLY supports these AMD tpm cycles. 0xFED4_0xxx --> 0x0xxx 0xFED4_1xxx --> 0x1xxx 0xFED4_2xxx --> 0x2xxx 0xFED4_3xxx --> 0x3xxx 0xFD_F920_0000~0xFD_F923_FFFF --> 0x4028 0xFD_F928_0000~0xFD_F928_0003 --> 0x4020 0xFD_F928_0004~0xFD_F928_0007 --> 0x4024~0x4027
Tpm_legacy	2	0b	When set to 1, it enables decoding of legacy tpm addresses, i.e., io addresses 7E/7F and EE/EF will be decoded.
Tmkbc_enable	3	0b	Enable bit for the TMKBC function
Tmkbc_set	4	0b	Write once bit. Once set, all tmkbc address/remap registers cannot be changed until the next reset.
Tmkbc_sel	6:5	0b	Selects which one of four sets of tmkbc registers at 84, 88, and 8Ch to be accessed.
WiderTpmEn	7	0b	Set to 1 to force logic to decode FED4xxxx as TPM cycles instead of FED4_0xxx, FED4_1xxx, FED4_2xxx, FED4_3xxx, and FED4_4xxx.

TPM (trusted plant form module) register- W/R - 8 bits - [PCI_Reg: 7Ch]			
Field Name	Bits	Default	Description
Note: Any tpm cycle above is decoded only when the cycle is started by ALinkBridge. Access from bus master devices is not allowed.			

LPCCLKCntl - R/W - 8 bits - [Offset 7Dh]			
Field Name	Bits	Default	Description
GpioLpcClk1	0		Read only. Status of LpcClk1 port
GpioLpcClk1OeB	1	1b	R/W, 1: Disable GpioLpcClk1 output 0: Enable GpioLpcClk1 output
GpioLpcClk1Out	2	0b	R/W, control GpioLpcClk1 output value
LpcClk1IsGpio	3	1b	R/W, 1: Treat LpcClk1IsGpio as Gpio 0: Treat LpcClk1IsGpio as LpcClk1
Reserved	7:4	0000b	

MSI Capability Register- R - 32 bits - [PCI_Reg: 80h]			
Field Name	Bits	Default	Description
CAP ID	7:0	08h	CAP ID.
CAP Next Pointer	15:0	0000h	CAP Next Pointer.
CAP Enable	16	1b	CAP Enable.
CAP Fixed	17	1b	CAP Fixed.
Reserved	26:18	0b	
CAP Type	31:27	15h	CAP Type.

TMKBC_BaseAddrLow Register- R/W - 32 bits - [PCI_Reg: 84h]			
Field Name	Bits	Default	Description
Reserved	1:0	00b	
Addr64	2	0b	Bit [2] defines whether the address is 32 or 64 bits. When bit [2] = 1, the address is 64 bits; 0 means 32 bits.
MaskBits10thru8	3	0b	Bit [3] defines whether address bits [10:8] are masked. 1 = masked, 0 = no mask ("masked" means bits 10:8 are don't care)
MaskBits11thru8	4	0b	Bit [4] defines whether address bits [11:8] are masked. 1 = masked, 0 = no mask
MaskBits12thru8	5	0b	Bit [5] defines whether address bits [12:8] are masked. 1 = masked, 0 = no mask
MaskBits13thru8	6	0b	Bit [6] defines whether address bits [13:8] are masked. 1 = masked, 0 = no mask
TMKBC_BaseAddrLow	31:7	000000h	This register defines the lower 32 bit memory address used for the TMKBC function. There are actually four sets of such mapping. The selection is controlled by PCI register 7Ch, bits [6:5]. 00 = set 0, 01 = set 1, 10 = set 2, 11 = set 3

TMKBC_BaseAddrHigh Register- R/W - 32 bits - [PCI_Reg: 88h]			
Field Name	Bits	Default	Description
TMKBC_BaseAddrHigh	31:0	00000000h	This register defines the upper 32 bit memory address used for the TMKBC function. This register has no meaning if bit 2 of 84h is set to 0. There are actually four sets of such mapping. The selection is controlled by PCI register 7Ch, bits [6:5]. 00 = set 0, 01 = set 1, 10 = set 2, 11 = set 3

TMKBC_Remap Register- R/W - 16 bits - [PCI_Reg: 8Ch]			
Field Name	Bits	Default	Description
TMKBC_Remap	15:8	00h	This register defines the remap address [15:8] on the LPC bus. There are actually four sets of such mapping. The selection is controlled by PCI register 7Ch, bits [6:5]. 00 = set 0, 01 = set 1, 10 = set 2, 11 = set 3
Reserved	7:0	0h	

Wide IO 2 Register- R/W - 16 bits - [PCI_Reg: 90h]			
Field Name	Bits	Default	Description
IO Base Address 2	15:0	0000h	16-bit PCI IO base address for wide generic port range. 512 byte wide range. This function is enabled by PCI register 4Bh, bit 1

IMCGpioCntrl- R/W - 16 bits - [Offset 92h]			
Field Name	Bits	Default	Description
IMCGpio_ImcLock	15:0	0000h	If the bit is set, BIOS can no longer access the corresponding bit in IMC_Gpio_Out[15:0] and IMC_Gpio_OeB[15:0] registers. These bits can only be written once. Write many by the Integrated micro-controller (IMC).

IMCaCntrl- R/W - 16 bits - [Offset 94h]			
Field Name	Bits	Default	Description
IMCaGpio_ImcLock	7:0	0000h	If the bit is set, the BIOS can no longer access the corresponding bit in AltKSI_Out and AltKSI_OeB registers. These bits are write once. Write many by the Integrated micro-controller (IMC).

IMCbCntrl- R/W - 16 bits - [Offset 96h]			
Field Name	Bits	Default	Description
IMCbGpio_ImcLock	15:0	0000h	If the bit is set, the BIOS can no longer access the corresponding bit in AltKSO_Out and AltKSO_OeB registers. These bits are write once. Write many by the Integrated micro-controller (IMC).

HostOwnLPC- R/W – 8 bits - [Offset 98h]			
Field Name	Bits	Default	Description
HostHoldLPC	0	0h	If the bit is set, Host owns LPC module. The bit can be read/write by IMC and Host
Reserved	7:1	0h	

ImcOwnLPC- R/W – 8 bits - [Offset 99h]			
Field Name	Bits	Default	Description
ImcHoldLPC	0	0h	If the bit is set, IMC owns LPC module. The bit can be read/write by IMC only
Reserved	7:1	0h	

IMC_Misc0- R/W - 4 bits - [Offset 9Bh]			
Field Name	Bits	Default	Description
ImcGpio_ImcLock	1:0	00b	If the bit is set, BIOS can no longer access the corresponding bit in ImcGpio_Out[17:16] and ImcGpio_OeB[17:16] registers. These bits are write once by the host. Write many by the Integrated micro-controller (IMC).

IMC_Misc0- R/W - 4 bits - [Offset 9Bh]			
Field Name	Bits	Default	Description
ImcGpio_Status	3:2	----	Read only, those bit represent the input state of ImcGpio[17,16]

Reserved – R/W - 32 bits - [Offset 9Ch]			
Field Name	Bits	Default	Description
Reserved	31:0	00000000h	

SPI Base Addr Register- R/W - 16 bits - [PCI_Reg: A0h]			
Field Name	Bits	Default	Description
AltSpiCSEnable	0	0b	When this bit is set, SPI_CS# is routed to a different pin (TBD)
SpiRomEnable	1	1b	When this bit is set and the chip is strapped to SPI Rom, SPI Rom is enabled; otherwise, SPI Rom is disabled.
AbortEnable	2	0b	Set the bit to 1 to abort the PCI request. When the cycles go to LPC, LPC will abort it.
Reserved	4:3	0b	Reserved.
SPI_BaseAddr	31:5	0000000h	This register defines the base address for the SPI ROM controller

IMC_PortAddress- R/W - 16 bits - [PCI_Reg: A4h]			
Field Name	Bits	Default	Description
IMC_PortActive	0	1b	When sets it to 1, LPC can decode the address specified in IMC_PortAddress otherwise LPC ignores it.
Addr15_1	15:1	0017h	When Addr15_1 is non-zero, and if an IO cycle from host has address[15:1] = Addr15_1, the cycle will be routed to IMC instead of to LPC bus. By default, address[15:0] = 002Eh or 002Fh will be routed. Read-only to host if IMC_PortHostAccessEn = 0.

RomDmaSrcAddr- R/W - 16 bits - [PCI_Reg: B0h]			
Field Name	Bits	Default	Description
Reserved	1:0	00b	
DmaStartAddr	31:6	00000000h	This register defines the starting DMA address to read from the ROM. Note this is not the same as the legacy DMA function. This is meant to be used by the BIOS to fetch BOOT codes quicker.

RomDmaTargetAddr- R/W - 16 bits - [PCI_Reg: B4h]			
Field Name	Bits	Default	Description
Reserved	5:0	00b	
DmaTargetAddr	31:6	00000000h	This register defines the target DMA address to be written in the system memory. Note this is not the same as the legacy DMA function. This is meant to be used by the BIOS to fetch BOOT codes quicker.

RomDmaControl- R/W - 16 bits - [PCI_Reg: B8h]			
Field Name	Bits	Default	Description
DmaStart	0	0b	Setting this bit will cause LPC bridge to start the DMA function, with starting addresses defined by regB0h and regB4h. The bit will return to status of DMA transfer. 0 of return value means DMA transfer is completed. 1 of return value means DMA transfer is running. Before that software can read this bit but write to it has no effect.
DmaErrorStatus	1	0b	Read only, 1 means that the previous transfer has error. 0 means that the previous transfer has completed successfully.
Reserved	5:2	0000h	
DWCount	15:6	0000h	This register defines the number of cacheline(64 bytes) to be fetched from the ROM when DMA is used.

ImcControl- R/W - 8 bits - [PCI_Reg: BAh]			
Field Name	Bits	Default	Description
IMC Page Protect	0	0b	Enables the protection of IMC page registers. 1: regBCh~C7h are only read/writeable by IMC. Host write to them has no effect. Host read from them returns 0. 0: regBCh~C7h are read/writeable by both IMC and Host.
PrefetchEnSystemem	1	0b	Sets the bit to 1 to enable prefetch a cacheline(64 bytes) when IMC read code from system memory
PrefetchEnSPIFromIMC	2	0b	Sets the bit to 1 to enable prefetch a cacheline(64 bytes) when IMC read code from the SPI rom.
IMC_PortHostAccessEn	3	0b	Sets to 1 to allow Host to program IMC_PortAddress register
Reserved	7:4	0000b	Spare bits
Note: This register is read/write by IMC, and read-only by Host.			

HostControl- R/W - 8 bits - [PCI_Reg: BBh]			
Field Name	Bits	Default	Description
PrefetchEnSPIFromHost	0	0b	Sets the bit to 1 to enable prefetch a cacheline(64 bytes) when Host read code from SPI rom
LpcCompletion	1	0b	Reserved. Software should not program this register bit. It should be set to 0 for normal operation.
BlockTPMonImc	2	0b	Set to 1 to block TPM cycle when IMC is accessing LPC. The bit should be set all the time.
ImcAccessEn0	3	0b	Set to 1 to use retry address as request address to IMC. The bit has to be set all the time.
ImcAccessEn1	4	0b	Set to 1 to use retry address all the time when receiving IMC request.
SpiOpEnInLpcMode	5	0b	Set to 1 to allow SPI op code to be executed even it is strapped with LPC rom
RtnMaskOffOnAbort	6	0b	Set to 1 to mask the byte to be offh if the byte access is aborted in LPC bus. The bit has to be set all the time.
ResetOnImc	7	0b	Set to 1 to gate off PCI reset to LPC when IMC is accessing LPC. The bit has to be set all the time
Note: This register is read/write by IMC and Host.			

IMCInstrRomPage- R/W – 16 bits - [PCI_Reg: BCh]			
Field Name	Bits	Default	Description
IMC_InstrRomPage	15:0	FFF2h	This page register constitutes address[31:16] when IMC fetches instructions from ROM. Read/writeable by Host only when regBAh[4]=0.

IMCRomFlashPage- R/W - 16 bits - [PCI_Reg: C0h]			
Field Name	Bits	Default	Description
IMC_RomFlashPage	15:0	0000h	This page register constitutes address[31:16] when IMC write to ROM to flash it. Read/writeable by Host only when regBAh[4]=0.

ImcGpio_Out – R/W - 16 bits - [Offset C6h]			
Field Name	Bits	Default	Description
IMC_Gpio_Out	15:0	0000h	Bit [0] controls the output state of IMC_Gpio[0], [1] for IMC_Gpio[1], ... etc. 0: Low 1: High If bit(s) in index A0h is set, BIOS can no longer write to the corresponding bit in this register.

ImcGpio_OeB – R/W - 16 bits - [Offset C8h]			
Field Name	Bits	Default	Description
IMC_Gpio_OeB	15:0	FFFF	Bit [0] controls the output enable bar of IMC_Gpio[0], [1] for IMC_Gpio[1], ... etc. 0: Enable 1: Tristate If bit(s) in index A0h is set, the BIOS can no longer write to the corresponding bit in this register

IMC_GpioStatus- R - 16 bits - [Offset CAh]			
Field Name	Bits	Default	Description
IMC_Gpio_Status	15:0	----	Bit [0] represents the input state of IMC_Gpio[0], [1] for IMC_Gpio[1], ... etc

IMCGpio_PDControl – R/W - 16 bits - [Offset CCh]			
Field Name	Bits	Default	Description
IMC_GpioPD	15:0	0000h	Each bit controls the integrated pull down resistor of IMC_Gpio pin. Bit [0] for IMC_Gpio[0], [1] for IMC_Gpio[1], ... etc 1: Enable 0: Disable

IMCGpio_PUControl – R/W - 16 bits - [Offset CEh]			
Field Name	Bits	Default	Description
IMC_GpioPUB	15:0	0000h	Each bit controls the integrated pull up resistor of IMC_Gpio pin. Bit [0] for IMC_Gpio[0], [1] for IMC_Gpio[1], ... etc 1: Disable 0: Enable

IMCa_Out- R/W - 8 bits - [Offset D0h]			
Field Name	Bits	Default	Description
IMCa_Gpio_Out	7:0	00h	Bit [0] controls the output of IMC_GPIO[18], [1] for IMC_GPIO[19], ... etc. 0: Enable 1: Tristate If bit(s) in index 98h is set, the BIOS can no longer write to the corresponding bit in this register

IMCa_OeB- R/W - 8 bits - [Offset D1h]			
Field Name	Bits	Default	Description
IMCa_Gpio_OeB	7:0	FFh	Bit [0] controls the output enable bar of IMC_GPIO[18], [1] for IMC_GPIO[19], ... etc. 0: Enable 1: Tristate If bit(s) in index 98h is set, the BIOS can no longer write to the corresponding bit in this register

IMCa_Status- R - 8 bits - [Offset D2h]			
Field Name	Bits	Default	Description
IMCa_Gpio_Status	7:0	--	Returns the input status of each pin IMC_GPIO[25:18]

IMCa_PDControl – R/W - 8 bits - [Offset D3h]			
Field Name	Bits	Default	Description
IMCa_GpioPD	7:0	00h	Each bit controls the integrated pull down resistor of KSIgpios pin. Bit [0] for IMC_GPIO[18], [1] for IMC_GPIO[19], ... etc 1: Enable 0: Disable

IMCa_PUControl – R/W - 8 bits - [Offset D4h]			
Field Name	Bits	Default	Description
IMCa_GpioPUB	7:0	00h	Each bit controls the integrated pull up resistor of KSIgpios pin. Bit [0] for IMC_GPIO[18], [1] for IMC_GPIO[19], ... etc 1: Disable 0: Enable

IMCb_Out – R/W - 16 bits - [Offset D5h]			
Field Name	Bits	Default	Description
IMCb_Gpio_Out	15:0	0000h	Bit [0] controls the output state of IMC_GPIO[26], [1] for IMC_GPIO[27], ... etc. 0: Low 1: High If bit(s) in index 90h is set, the BIOS can no longer write to the corresponding bit in this register.

IMCb_OeB – R/W - 16 bits - [Offset D7h]			
Field Name	Bits	Default	Description
IMCb_Gpio_OeB	15:0	FFFF	Bit [0] controls the output enable bar of IMC_GPIO[26], [1] for IMC_GPIO[27], ... etc. 0: Enable 1: Tristate If bit(s) in index 90h is set, the BIOS can no longer write to the corresponding bit in this register

IMCb_Status- R - 16 bits - [Offset D9h]			
Field Name	Bits	Default	Description
IMCb_Gpio_Status	15:0	----	Bit [0] represents the input state of IMC_GPIO[26], [1] for IMC_GPIO[27], ... etc

IMCb_PDControl – R/W - 16 bits - [Offset DBh]			
Field Name	Bits	Default	Description
IMCb_GpioPD	15:0	0000h	Each bit controls the integrated pull down resistor of IMC_Gpio pin. Bit [0] for IMC_GPIO[26], [1] for IMC_GPIO[27], ... etc 1: Enable 0: Disable

IMCb_PUControl – R/W - 16 bits - [Offset DDh]			
Field Name	Bits	Default	Description
IMCb_GpioPUB	15:0	0000h	Each bit controls the integrated pull up resistor of IMC_Gpio pin. Bit [0] for IMC_GPIO[26], [1] for IMC_GPIO[27], ... etc 1: Disable 0: Enable

IMCc_Misc1 – R/W - 8 bits - [Offset DFh]			
Field Name	Bits	Default	Description
IMCc_Gpio_Out	1:0	00b	Bit [0] controls the output state of IMC_GPIO[16], [1] for IMC_GPIO[17], ... etc. 0: Low 1: High If bit(s) in index A0h is set, the BIOS can no longer write to the corresponding bit in this register.
IMCc_Gpio_OeB	3:2	11b	Bit [0] controls the output enable bar of IMC_Gpio[16], [1] for IMC_Gpio[17], ... etc. 0: Enable 1: Tristate If bit(s) in index A0h is set, BIOS can no longer write to the corresponding bit in this register
IMCc_GpioPD	5:4	00b	Each bit controls the integrated pull down resistor of IMC_GPIO pin. Bit [0] for IMC_GPIO[16], [1] for IMC_GPIO[17], ... etc 1: Enable 0: Disable
IMCc_GpioPUB	7:6	00b	Each bit controls the integrated pull up resistor of IMC_GPIO pin. Bit [0] for IMC_GPIO[16], [1] for IMC_GPIO[17], ... etc 1: Disable 0: Enable

3.1.3 SPI ROM Controller Registers

The SPI interface can support the low cost SPI ROM devices that can be used for the BIOS ROM just as the LPC or the FWH ROM is supported on the LPC interface. Only one interface can be supported at a time. The SPI interface can be enabled by the hardware strap options.

Software can communicate with the SPI ROM through the default memory or alternate program method.

Memory access to the BIOS ROM address space is automatically handled by the hardware. The SPI ROM controller will translate the memory address onto the SPI bus and access the SPI ROM data. Any other commands besides `memory_read` or `memory_write` to the SPI ROM will need to go through the alternate program method. In this method, software will need to program the `OpCode`, `SpiAddress`, `TxByteCount`, `RxByteCount`, put the data into the transmit FIFO, and then execute the command. The hardware will then communicate with the SPI ROM using these parameters. This method is needed for the case of erasing the SPI ROM since SPI ROM has to be erased first before any new data can be written with a separate memory write command. This is also useful for querying the SPI status and `vendor_ID` register.

SPI_Cntrl0 Register- R/W - 16 bits - [Offset 00h]			
Field Name	Bits	Default	Description
SPI_OpCode	7:0	0	When software uses the alternate program method to communicate with the SPI ROM, this register contains the OPCODE
TxByteCount	11:8	0	Number of bytes to be sent to SPI ROM
RxByteCount	15:12	0	Number of bytes to be received from the SPI ROM
ExecuteOpCode	16	0	Write 1 to execute the transaction in the alternate program registers. Write 0 has no effect. When the transaction is complete, this bit will return 0. If the command is an illegal command, the bit cannot be set and thereby cannot execute
Reserved	18:17	00	
SpiArbEnable	19	1	If a MAC is sharing the ROM with the SB, both chips will need to go through an arbitration process before either one can access the ROM. This bit enables the arbitration. If MAC is not sharing the SPI ROM, BIOS should set this bit to 0 to speed up the SPI ROM access
FifoPtrClr	20	0 (WO)	A write of 1 to this bit will clear the internal FIFO pointer
FifoPtrInc	21	0 (WO)	A write of 1 to this bit will cause the internal FIFO pointer to be incremented by 1
SpiAccessMacRomEn	22	1	This is a clear-once protection bit; once cleared, software cannot access MAC's portion of the ROM space (lower 512KB). However, IMC can always read/write this bit.
SpiHostAccessRomEn	23	1	This is a clear-once protection bit; once cleared, the host cannot access BIOS ROM space (upper 512KB). However, IMC can always read/write this bit. Please note this bit will also prevent the host from issuing any restricted commands through the indirect method of accessing the SPI ROM via bit 16 of index 00h. Restricted commands are defined in index 04 and 08h.
ArbWaitCount	26:24	100	Under ROM sharing mode (with the MAC) this defines the amount of wait time this controller will assert HOLD# before it should access the SPI ROM. This time is to allow the MAC to sample HOLD#.
SpiBridgeDisable	27	0	Setting this bit will disable the SPI bridge mode (the SP5100 will act as a SPI-LPC bridge to the MAC)
DropOneClkOnRd	28	0	Set to 1 to force one clock to be dropped off when it is doing read.
Reserved	31:28	0	

SPI_RestrictedCmd Register- R/W - 16 bits - [Offset 04h]			
Field Name	Bits	Default	Description
RestrictedCmd0	7:0	0	This defines a restricted command issued by the MAC or Host which will be checked by the SP5100. If the opcode issued by the matches with this register and the address space is in the BIOS space, this controller will simply ignore the command for the case of bridge mode. For peer mode, the SPI controller will jam the entire interface as an attempt to stop that transaction. The denial for access also applies for the case of opcode issued by the host through the indirect method (setting index00h, bit 16) Note that once either SpiAccessMacRomEn and/or SpiHostAccessRomEn bit is cleared, these registers become read only and cannot be changed any more.
RestrictedCmd1	15:8	0	Same as RestrictedCmd0
RestrictedCmd2	23:16	0	Same as RestrictedCmd0
RestrictedCmd3	31:24	0	Same as RestrictedCmd0

SPI_RestrictedCmd2 Register- R/W - 16 bits - [Offset 08h]			
Field Name	Bits	Default	Description
RestrictedCmd4	7:0	0	Same as RestrictedCmd0
RestrictedCmdWoAddr 0	15:8	0	Same as RestrictedCmd0 except this command does not have address
RestrictedCmdWoAddr 1	23:16	0	Same as RestrictedCmd0 except this command does not have address
RestrictedCmdWoAddr 2	31:24	0	Same as RestrictedCmd0 except this command does not have address

SPI_Cntrl1 Register- R/W - 16 bits - [Offset 0Ch]			
Field Name	Bits	Default	Description
SPIParameters	7:0	0	This is the TX/RX FIFO port which can take up to 8 bytes. To send data to SPI ROM, software writes data into this port. To retrieve data that are received from the SPI ROM, software reads from this port.
FifoPtr	10:8	000	This three bits show the internal pointer location
TrackMacLockEn	11	0	When set, the controller will lock the SPI for the MAC when it has detected a command (from the MAC) matching the value defined in offset 10h or 11h. Conversely, it will unlock the bus when it has detected a command (from the MAC) matching the value defined in offset 12h or 13h
NormSpeed	13:12	11	This defines the clock speed for the non-fast read command 00: Reserved 01: 33Mhz 10: 22 Mhz 11: 16.5Mhz
Reserved	15:14	01	
RestrictedCmdWoAddr 1	23:16	0	Same as RestrictedCmd0 except this command does not have address
RestrictedCmdWoAddr 2	31:24	0	Same as RestrictedCmd0 except this command does not have address

Note: Either SpiAccessMacRomEn and/or SpiHostAccessRomEn bit is cleared, these registers; RestrictedCmdWoAddr and RestrictedCmdWoAddr2 become read only and cannot be changed any further.

SPI_CmdValue0 Register- R/W - 16 bits - [Offset 10h]			
Field Name	Bits	Default	Description
MacLockCmd0	7:0	06h	This is used to compare against the opcode sent out by the MAC. If SPI_Cntrl1[11] is set, the controller will lock the SPI bus for the MAC. In other words, the MAC has the exclusive access to the ROM; access by the CPU will be delayed until this is unlocked. This is to allow the MAC to do certain sequence of operations without interruption.
MacLockCmd1	15:8	20h	Same as MacLockCmd0
MacUnlockCmd0	23:16	04h	This is used to compare against the opcode sent out by the MAC. If SPI_Cntrl1[11] is set, the controller will unlock the SPI bus for the MAC. In other words, access by the CPU will be allowed again.
MacUnlockCmd1	31:24	04h	Same as MacUnlockCmd0

Note: Either SpiAccessMacRomEn and/or SpiHostAccessRomEn bit is cleared, or all of these registers become read only and cannot be changed any further.

SPI_CmdValue1 Register- R/W - 16 bits - [Offset 14h]			
Field Name	Bits	Default	Description
WREN	7:0	06h	This is used to compare against the opcode sent out by the MAC. This is a predefined value to decode for the WREN (write enable) command from the MAC. In the bridge mode, SP5100 will need to decode commands from the MAC
WRDI	15:8	04h	This is used to compare against the opcode sent out by the MAC. This is a predefined value to decode for the WRDI (write disable) command from the MAC.
RDID	23:16	9Fh	This is used to compare against the opcode sent out by the MAC. This is a predefined value to decode for the RDID (read ID) command from the MAC
RDSR	31:24	05h	This is used to compare against the opcode sent out by the MAC. This is a predefined value to decode for the RDSR (read status register) command from the MAC

Note: Either SpiAccessMacRomEn and/or SpiHostAccessRomEn bit is cleared, or all of these registers become read only and cannot be changed any further.

SPI_CmdValue2 Register- R/W - 16 bits - [Offset 18h]			
Field Name	Bits	Default	Description
Read	7:0	03h	This is used to compare against the opcode sent out by the MAC. This is a predefined value to decode for the Read (Read byte) command from the MAC. In the bridge mode, SP5100 will need to decode commands from the MAC
FRead	15:8	0Bh	This is used to compare against the opcode sent out by the MAC. This is a predefined value to decode for the FRead (fast read) command from the MAC.
PAGEWR	23:16	0Ah	This is used to compare against the opcode sent out by the MAC. This is a predefined value to decode for the PAGEWR (page write) command from the MAC
BYTEWR	31:24	02h	This is used to compare against the opcode sent out by the MAC. This is a predefined value to decode for the BYTEWR (byte write) command from the MAC

Note: Either SpiAccessMacRomEn and/or SpiHostAccessRomEn bit is cleared, or all of these registers become read only and cannot be changed any further.

SPI_FakeID Register- R/W - 8 bits - [Offset 1Ch]			
Field Name	Bits	Default	Description
SPI_FakeID	7:0	FFh	This is used as the faked ID value to be returned to the MAC as a response to the RDID command. This is only used under the bridge mode.

3.1.4 Features of the LPC Block

Bus Speed: PCI bus—66/33MHz, LPC bus—33MHz

Supported peripherals and address:

- I/O address devices:
 - Parallel Ports: 378~37fh, 778~77fh, 278~27fh, 678~67fh, 3bc~3bfh, 7bc~7bfh
 - Serial Ports: 3f8~3ffh, 2f8~2ffh, 220~227h, 228~22fh, 238~23fh, 2e8~2efh, 338~33fh, 3e8~3efh
 - Audio: 220~233h, 240~253h, 260~273h, 280~293h
 - MIDI: 300~301h, 310~311h, 320~321h, 330~331h
 - MSS: 530~537h, 604~60bh, e80~e87h, f40~f47h
 - FDC: 3f0~3f7h (excluding 3f6h), 370~377h (excluding 376h)
 - Game Ports: 200~20fh
 - Wide Generic: Can be mapped anywhere in lower 64KB I/O address. 512 bytes wide.
 - RTC: 70~73h
 - Key Board Controller: 60h, 64h
 - ACPI Micro-Controller: 62h, 66h
 - Ad-Lib: 388h~389h
 - Super I/O Configuration: 2e~2fh
 - Alternative Super I/O Configuration: 4e~4fh
- Memory address devices:
 - ROM: supported address is in the range of 0000_0000h~ffff_ffffh
 - Firmware Hub Rom: supported address is in one of these two ranges: 000e_0000h~000f_ffffh, or ffb0_0000~ffff_ffffh

3.2 Host PCI Bridge Registers (Device 20, Function 4)

PCI Host Bridge is supported with PCI configuration space registers. These registers are cleared by PCIRST#; therefore they will be cleared on a warm boot.

Note: Some PCI functions are controlled by, and associated with, certain PCI configuration registers in the SMBus/ACPI device. For more information refer to [section 2.4: SMBus Module and ACPI Block \(Device 20, Function 0\)](#). The diagram below lists these PCI functions and the associated registers.

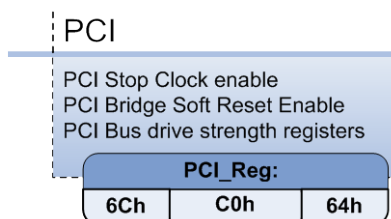

PCI Bridge (PCIB) has one set of configuration registers in PCI configuration space identified by PCI function 4 on the South Bridge.

Table 3-1 PCI-to-PCI Bridge Configuration Registers Summary

Register Name	Offset Address
Vendor ID	00h
Device ID	02h
PCI Command	04h
PCI Device Status	06h
Revision ID/Class Code	08h
Cache Line Size	0Ch
Latency Timer	0Dh
Header Type	0Eh
Reserved	0Fh
Primary Bus Number	18h
Secondary Bus Number	19h
Subordinate Bus Number	1Ah
Secondary Latency Timer	1Bh
IO Base	1Ch
IO Limit	1Dh
Secondary Status	1Eh
Memory Base	20h
Memory Limit	22h
Prefetchable Memory Base	24h
Prefetchable Memory Limit	26h
IO Base Upper 16 Bits	30h
IO Limit Upper 16 Bits	32h
Capability pointer	34h
Reserved	36h
Interrupt Line	3Ch
Interrupt Pin	3Dh
Bridge Control	3Eh
Chip Control	40h
Diagnostic Control	41h
CLK Control	42h
Arbiter Control and Priority Bits	43h

Register Name	Offset Address
SMLT Performance	44h
PMLT Performance	46h
PCDMA	48h
Additional Priority	49h
PCICLK Enable Bits	4Ah
Misc Control	4Bh
AutoClockRun Control	4Ch
Dual Address Cycle Enable and PCIB_SCLK_Stop Override	50h
MSI Mapping Capability	54h
Signature Register for Microsoft Rework for Subtractive Decode	58h
Prefetch Timeout Limit	5Ch
SPCI IDSEL MaskB	5Eh
Prefetch Size Control	60h
Misc Control	64h

Vender ID - R - 16 bits - [PCI_Reg: 00h]			
Field Name	Bits	Default	Description
VID	15:0	1002h	Vendor ID
Vendor ID register			

Device ID - R - 16 bits - [PCI_Reg: 02h]			
Field Name	Bits	Default	Description
DID	15:0	4384h	Device ID
Device ID register			

Command - RW - 16 bits - [PCI_Reg: 04h]			
Field Name	Bits	Default	Description
IO Enable	0	0b	IO response enable. PCIB responses IO space accesses on primary bus. 0: Disable 1: Enable
Memory Enable	1	0b	Memory response enable. PCIB responses memory space accesses on primary bus. 0: Disable 1: Enable
Master Enable	2	0b	Master enable. Provides the ability of PCIB to act as a PCI bus master on primary bus. 0: Disable 1: Enable
Special Enable	3	0b	Hardwired to 0 to indicate that PCIB ignores special cycles.
Mem Invalidate	4	0b	Hardwired to 0 to indicate that PCIB doesn't issue memory write and invalidate command by itself.
VGA Snoop Enable	5	0b	VGA snoop enable. When '0' VGA palette write transactions on the primary interface are ignored unless it falls into PCIB's IO address range. When '1' VGA palette write transactions are positively decoded and forwarded downstream.
Parity Error Enable	6	0b	Parity Error Response. 0: Disables PCIB to assert P_SERR# and P_PERR# or report Detected Parity Error to the status register 1: Enables PCIB.
Addr Stepping Enable	7	0b	Controls whether or not to do address/data stepping, PCIB doesn't. Read Only

Command - RW - 16 bits - [PCI_Reg: 04h]			
Field Name	Bits	Default	Description
System Error Enable	8	0b	SERR# enable. 0: Disables PCIB to assert P_SERR# and report Signaled System Error bit 1: Enables PCIB.
Fast Back-to-Back Enable	9	0b	Hardwired to 0 to indicate that PCIB is not capable of issuing fast back-to-back transactions on the primary bus.
Reserved	15:10	00h	Reserved
PCI Command register			

Status- RW - 16 bits - [PCI_Reg: 06h]			
Field Name	Bits	Default	Description
Reserved	3:0	0h	Reserved
Capabilities List	4	0b	Read only. This bit is 1 when Offset 40h [3] = 1. At other time this bit is 0. 0: The bridge does not support the Capabilities List 1: The bridge supports the Capabilities List (Offset 34h is the pointer to the data structure).
66MHz Capable	5	1b	Hardwired to 1 to indicate PCIB support of 66MHz primary interface.
Reserved	6	0b	Reserved
Fast Back-to-Back Capable	7	1b	Hardwired to 1 to indicate PCIB is capable of accepting fast back-to-back transactions on the primary bus.
Master Parity Error	8	0b	Master Data Parity Error, assertion of P_PERR# (when PCIB acts as a master) is received, write clears it.
DevSel Timing	9:10	01b	Hardwired to 01b to indicate PCIB will assert DEVSEL# with medium timing.
Target Abort	11	0b	Signaled Target Abort, write clears it.
Received Target Abort	12	0b	Received Target Abort, write clears it.
Received Master Abort	13	0b	Received Master Abort, write clears it.
Master Abort	14	0b	Signaled System Error bit, write clears it.
Parity Error	15	0b	Detected Parity Error, PCIB detected a parity error and will assert P_PERR#, write clears it.
PCI device status register.			

Revision ID/Class Code- R - 32 bits - [PCI_Reg: 08h]			
Field Name	Bits	Default	Description
Revision ID	7:0	00h	These bits are hardwired to 00h to indicate the revision level of the chip design (for the SP5100).
Class Code	31:8	060401h/ 060400h	A class code of 06h indicates a bridge device, a subclass code of 04h indicates PCI bridge and a programming interface of '01h' indicates subtractive decoding on primary bus is supported. Based on Reg0x4B[7], this register is programmed as positive decode bridge or subtractive decode bridge.
Revision ID/Class Code register.			

Cache Line Size- RW - 8 bits - [PCI_Reg: 0Ch]			
Field Name	Bits	Default	Description
Cache Line Size	7:0	00h	Read Only
Cache line size register			

Primary Master Latency Timer- RW - 8 bits - [PCI_Reg: 0Dh]			
Field Name	Bits	Default	Description
Prim Latency Timer	7:0	00h	Primary master latency timer. Sets the minimum time that the Primary bus master can retain the ownership of the bus.

Primary Master Latency Timer- RW - 8 bits - [PCI_Reg: 0Dh]			
Field Name	Bits	Default	Description
Primary Master Latency timer register			

Header Type- R - 8 bits - [PCI_Reg: 0Eh]			
Field Name	Bits	Default	Description
Header Type	7:0	81h	Indicates the bridge is a multi-function device.
Header type register			

Primary Bus Number- RW - 8 bits - [PCI_Reg: 18h]			
Field Name	Bits	Default	Description
Primary Bus Number	7:0	00h	Bus number of the PCI bus to which the primary interface is connected.
Primary Bus Number register			

Secondary Bus Number - RW - 8 bits - [PCI_Reg: 19h]			
Field Name	Bits	Default	Description
Secondary Bus Number	7:0	00h	Bus number of the PCI bus to which the secondary interface is connected.
Secondary Bus Number register			

SUBBN- RW - 8 bits - [PCI_Reg: 1Ah]			
Field Name	Bits	Default	Description
SubordinateBusNum	7:0	00h	Bus number of the highest numbered PCI bus behind PCIB.
Subordinate Bus Number register			

Secondary Latency Timber- RW - 8 bits - [PCI_Reg: 1Bh]			
Field Name	Bits	Default	Description
Secondary Latency Timer	7:0	00h	Secondary Master latency control timer. Sets the minimum time that the Secondary bus master can retain the ownership of the bus.
Secondary Master Latency Timer register			

IO Base- RW - 8 bits - [PCI_Reg: 1Ch]			
Field Name	Bits	Default	Description
IO16	1:0	00b	Indicates a 16-bit IO address space. Read Only Can be changed to 32-bit when bit[29] of regx48 is set
Reserved	3:2	00b	Reserved
IOBase	7:4	0h	Defines the bits [15:12] of the base address of 16-bit or 32-bit IO space.
IO base register			

IO Limit- RW - 16 bits - [PCI_Reg: 1Dh]			
Field Name	Bits	Default	Description
IO16	1:0	00b	Indicates a 16-bit IO address space. Read Only Can be changed to 32-bit when bit[29] of regx48 is set
Reserved	3:2	00b	Reserved
IO Limit	7:4	0h	Defines bits [15:12] of the limit of 16-bit or 32-bit IO space.
IO Limit register			

Secondary Status- RW - 16 bits - [PCI_Reg: 1Eh]			
Field Name	Bits	Default	Description
Reserved	4:0	00h	Reserved

Secondary Status- RW - 16 bits - [PCI_Reg: 1Eh]			
Field Name	Bits	Default	Description
Sec 66MHz Capable	5	0b	Indicates PCIB doesn't support 66MHz secondary interface. Read Only.
Reserved	6	0b	Reserved
Secondary Fast Back-to-Back Capable	7	1b	Indicates PCIB is capable of accepting fast back-to-back transactions on the secondary bus. Read Only.
Secondary Master Data Parity Error	8	0b	Master Data Parity Error on the secondary bus, assertion of S_PERR# (when PCIB acts as a master) is received, write clears it.
Secondary DevSel Timing	10:9	01b	DEVSEL# timing, indicates PCIB will assert DEVSEL# with medium timing on the secondary bus. Read Only.
Secondary Target Abort	11	0b	Signaled Target Abort on the secondary bus, write clears it.
Received Secondary Target Abort	12	0b	Received Target Abort on the secondary bus, write clears it.
Received Secondary Master Abort	13	0b	Received Master Abort on the secondary bus, write clears it.
Received Serr	14	0b	Received System Error on the secondary bus, PCIB asserts P_SERR# to propagate the error back to the primary bus, write clears it.
Data Parity Error	15	0b	Detected Parity Error on the secondary bus, PCIB detected a parity error and will assert S_PERR#, write clears it.
Secondary status register			

Memory Base- RW - 16 bits - [PCI_Reg: 20h]			
Field Name	Bits	Default	Description
Reserved	3:0	0h	Indicates a non-prefetchable 32-bit memory space. Read Only
Non Pref Mem Base	15:4	000h	Defines the highest 12 bits ([31:20]) of the base address of this 32-bit memory space.
Memory base register			

Memory Limit- RW - 16 bits - [PCI_Reg: 22h]			
Field Name	Bits	Default	Description
Reserved	3:0	0h	Indicates a non-prefetchable 32-bit memory space. Read Only.
Non Pref Mem Limit	15:4	000h	Defines the highest 12 bits ([31:20]) of the upper limit of this 32-bit memory space.
Memory limit register			

Prefetchable Memory Base- RW - 16 bits - [PCI_Reg: 24h]			
Field Name	Bits	Default	Description
Reserved	3:0	0h	Indicates a 32-bit only +memory space. Read Only
Pref Mem Base	15:4	000h	Defines the highest 12 bits ([31:20]) of the base address of this 32-bit memory space.
Prefetchable memory base register			

Prefetchable Memory Limit- RW - 16 bits - [PCI_Reg: 26h]			
Field Name	Bits	Default	Description
Reserved	3:0	0h	Indicates a 32-bit only memory space. Read Only.
Perf Mem Limit	15:4	000h	Defines the highest 12 bits ([31:20]) of the upper limit of this 32-bit memory space.
Prefetchable memory limit register			

IO Base Upper 16 Bits- RW - 16 bits - [PCI_Reg: 30h]			
Field Name	Bits	Default	Description
IOBase Upper	15:0	0000h	Top 16 bits of the base address of 32-bit IO transactions. If the IO address decode mode bit (Regx48 bit[29]) is clear then these bits will be zero
IO base upper 16 bits			

IO Limit Upper 16 bits- RW - 16 bits - [PCI_Reg: 32h]			
Field Name	Bits	Default	Description
IOLimit Upper	15:0	0000h	Top 16 bits of the upper limit of 32-bit IO transactions. If the IO address decode mode bit (Regx48 bit[29]) is clear then these bits will be zero
IO limit upper 16 bits			

Capabilities Pointer- R - 8 bits - [PCI_Reg: 34h]			
Field Name	Bits	Default	Description
Capabilities Pointer	7:0	00h	Enhanced Capability Pointer. Read Only. Value = 54h when Offset 40h [3] MSI Guide Bit set to '1'
Capability Pointer register			

Interrupt Line- R - 8 bits - [PCI_Reg: 3Ch]			
Field Name	Bits	Default	Description
Interrupt Line	7:0	00h	Interrupt pin routing information, used as communication window between BIOS and the device driver.
Interrupt Line register			

Interrupt Pin- R - 8 bits - [PCI_Reg: 3Dh]			
Field Name	Bits	Default	Description
Interrupt Pin	7:0	00h	Interrupt pin usage information. '0' indicates PCIB not supporting interrupt routing.
Interrupt Pin register			

Bridge Control- RW - 16 bits - [PCI_Reg: 3Eh]			
Field Name	Bits	Default	Description
Parity Error Enable	0	0b	Parity Error Response, '0' disables PCIB to assert P_SERR# and S_PERR# or report Detected Parity Error to the secondary status register, '1' enables PCIB.
Serr# Enable	1	0b	SERR# forward enable, when '0' PCIB doesn't drive P_SERR# when it detects S_SERR#.
ISA_Enable	2	0b	ISA enable, when '0' no ISA address mode, when '1' ISA address mode is supported.
VGA_Enable	3	0b	VGA enable, '0' disabled, '1' enabled.
VGA 16-bit decode	4	0b	This bit only has meaning if either bit 3 (VGA Enable) of this register, or bit 5 (VGA Palette Snoop Enable) of the Command Register, is also set to 1, thereby enabling VGA I/O decoding and forwarding by the bridge. The status after reset is 0. This read/write bit enables system configuration software to select between 10- and 16-bit I/O address decoding for all VGA I/O register accesses that are forwarded from primary to secondary. 0: Execute 10-bit address decodes on VGA I/O accesses. 1: Execute 16-bit address decodes on VGA I/O accesses

Bridge Control- RW - 16 bits - [PCI_Reg: 3Eh]			
Field Name	Bits	Default	Description
Master Abort Report	5	0b	Master abort mode. 0: Does not report master aborts (return FFFF,FFFFh on reads and discard data on write) 1: Reports master aborts by signaling target abort or by asserting SERR# if enabled.
Secondary Reset	6	0b	Secondary bus reset. This bit can be masked using acpi pci config register x6c bit [5] 0: Disable 1: Trigger reset
Secondary Fast Back-to-Back Enable	7	0b	Secondary bus fast back-to-back enable. PCIB is not capable of issuing fast back-to-back transactions on the secondary bus. Read Only
Primary Discard Timer	8	0b	Primary Discard Timer configuration 0: Configures the timer to 15-bit 1: Configures the timer to 10-bit
Secondary Discard Timer	9	0b	Secondary Discard Timer configuration 0: Configures the timer to 15-bit 1: Configures the timer to 10-bit
Discard Timer Status	10	0b	Discard Timer Status 0: No discard timer error 1: Discard timer error
Discard Timer Serr# Enable	11	0b	Discard Timer SERR# enable 0: Disable 1: Enable
Reserved	15:12	0h	Reserved
Bridge control register			

CPCTRL- RW - 8 bits - [PCI_Reg: 40h]			
Field Name	Bits	Default	Description
Reserved	0	0b	Reserved
Mem Write Size Ctrl	1	0b	Controls the Memory write size. When set the memory write size will be cacheline aligned else it will be 32 byte aligned.
Lock Enable	2	1b	Downstream locked transaction enable.
MSIC ap Enable	3	0b	MSI Capability Enable Guide bit. Setting this bit to '1' will change the status of Offset 04h [20] from '0' to '1' 1: Enable 0: Disable
Reserved	4	0b	Reserved
Sub Decode Enable	5	0b	This bit is used only when reg0x4B[7] = 1. 1: Subtractive decoding is enabled. 0: Subtractive decoding is disabled.
Bridge Lock State	7:6	00b	Bridge secondary master lock states. Read Only 00: Free 01: Busy 10: Req 11: Locked
Chip control register			

DCTRL- RW - 8 bits - [PCI_Reg: 41h]			
Field Name	Bits	Default	Description
Reserved	0	0b	Reserved
Timer Test Mode	2:1	00b	Timer Test Mode, 00: Normal operation, all bits are exercised 01: Byte 1 is exercised 10: Byte 2 is exercised 11: Byte 0 is exercised

DCTRL- RW - 8 bits - [PCI_Reg: 41h]			
Field Name	Bits	Default	Description
Force Parity Error	3	0b	Forces receiving/generating parity error 0: Receive 1: Generate
Force Data Parity Error	4	0b	Forces data parity error 0: Disable 1: Enable
Force Addr Parity Error	5	0b	Forces address parity error 0: Disable 1: Enable
Force Sec Parity Error	6	0b	Forces secondary Parity Error Mode 0: Disable 1: Enable
Force Prim Parity Error	7	0b	Forces primary Parity Error Mode 0: Disable 1: Enable
Diagnostic control register			

CLKCTRL- RW - 8 bits - [PCI_Reg: 42h]			
Field Name	Bits	Default	Description
PCICLKStopEnable	0	0b	33MHz PCICLKs request bit; when '1,' 33 MHz PCI Clocks are requested to stop.
PCICLKStopStatus	1	0b	Read only. 33MHz PCICLKs stop status: 1: Stopped 0: Running.
PCICLK0Enable	2	1b	33MHz PCICLK0 enable.
PCICLK1Enable	3	1b	33MHz PCICLK1 enable.
PCICLK2Enable	4	1b	33MHz PCICLK2 enable.
PCICLK3Enable	5	1b	33MHz PCICLK3 enable.
P2SControl	6	0b	P_CLK domain to S_CLK domain synch-up disable.
S2PControl	7	0b	S_CLK domain to P_CLK domain synch-up disable.
Clock control register			

ARCTRL- RW - 8 bits - [PCI_Reg: 43h]			
Field Name	Bits	Default	Description
Reserved	6:0	fff	Reserved
ArbiterEnable	7	1b	Arbiter enable 0: Disabled to give PCIB the exclusive ownership of the secondary bus.
Arbiter control register			

SMLT_PERF- RW - 16 bits - [PCI_Reg: 44h]			
Field Name	Bits	Default	Description
SMLT_Perf	15:0	0000h	Counts the total number of a burst being broken into multiple transactions due to MLT timeout.
Secondary MLT performance register			

PMLT_PERF- RW - 16 bits - [PCI_Reg: 46h]			
Field Name	Bits	Default	Description
PMLT_Perf	15:0	0000h	Counts the total number of a burst being broken into multiple transactions due to MLT timeout.
Primary MLT performance register			

PCDMA- RW - 8 bits - [PCI_Reg: 48h]			
Field Name	Bits	Default	Description
PCDMA Device Enable A	0	0b	Device enable for request 3. Needs to be enabled when there is a PCDMA device corresponding to request 3
PCDMA Device Enable B	1	0b	Device enable for request 4. Needs to be enabled when there is a PCDMA device corresponding to request 4
Fast Back to Back Retry Enable	2	0b	Retry Fast Back to Back transactions on Write buffer full.
Lock Operation Enable	3	1b	When reg0x40[2]=1, this bit should be set to 1 for the proper operation of the PCI LOCK# function.
Reserved	7:4	00h	Reserved
PCDMA device Enable bits			

Additional Priority- Bits RW - 8 bits - [PCI_Reg: 49h]			
Field Name	Bits	Default	Description
Reserved	0	1b	Reserved
PCDMA Priority	1	1b	If enabled includes PCDMA request into high priority list
Reserved	7:2	03h	Reserved
Priority Bits			

PCICLK Enable Bits- RW - 8 bits - [PCI_Reg: 4Ah]			
Field Name	Bits	Default	Description
PCICLK4Enable	0	1b	33MHz PCICLK4 enable.
PCICLK5Enable	1	1b	33MHz PCICLK 5 enable.
PCICLK6Enable	2	1b	33MHz PCICLK 6 enable.
PCICLK7Enable	3	1b	33MHz PCICLK 7 enable.
Reserved	7:4	3h	Reserved
PCICLK Enable bits			

Misc Control RW - 8 bits - [PCI_Reg: 4Bh]			
Field Name	Bits	Default	Description
GNT Bus Idle check enable	0	0b	When enabled, the PCI arbiter checks for the Bus Idle before asserting GNT#.
Memory Read Burst Size	4:1	0h	Specifies up to how many double words burst to support during an upstream or downstream memory read. [4:1] = 1xxx: Burst up to 16 double words 01xx: Burst up to 8 double words 001x: Burst up to 4 double words 0001: Burst up to 2 double words Others: Burst up to 8 double words Note 1: It has no effect on a downstream normal memory read (other than read line and read multiple), which has no burst in this design. Note 2: It has no effective on an upstream memory read if the read is prefetchable as specified by reg0x64[7] and reg0x64[21], because a prefetchable read can have unlimited burst.
IOMode	5	0b	Control bit to change the IO addressing mode to 32/16 bit. 0: 16 bits; 1: 32 bit.
MemReadCmdMatch	6	0b	Control bit to enable the match of memory read/memory read line commands when there is a read command in the Delay queue.

Misc Control RW - 8 bits - [PCI_Reg: 4Bh]			
Field Name	Bits	Default	Description
SubDecodeEnable	7	0b	Control bit for the subtractive decode status (09h). 0: No subtractive decode; 1: Whether subtractive decode is enabled depends on reg0x40[5].
Misc control Register			

AutoClockRun control RW - 32 bits - [PCI_Reg: 4Ch]			
Field Name	Bits	Default	Description
Autoclrun Enable	0	0b	Enables the auto clkrun functionality
Autoclrun count	31:1	0000_000 0h	Number of cycles after which the secondary clock stops when clkrun is enabled
Auto ClockRun control register			

Dual Address Cycle Enable and PCIB_CLK_Stop Override - RW - 16 bits - [PCI_Reg: 50h]			
Field Name	Bits	Default	Description
PCIB_Dual_EN_up	0	0b	Enables decoding of Dual Address Cycle on secondary side for upstream memory transactions
PCIB_Dual_EN_dn	1	0b	Enables decoding of Dual Address Cycle on secondary side for downstream memory transactions
Reserved	5:2	0h	
ClkrunOvrridePCICLK	6	0b	When set, overrides the CLKRUN# and 33MHz PCICLK continues to run.
ClkrunOvrridePCICLK1	7	0b	When set, overrides the CLKRUN# and 33MHz PCICLK1 continues to run.
ClkrunOvrridePCICLK2	8	0b	When set, overrides the CLKRUN# and 33MHz PCICLK2 continues to run.
ClkrunOvrridePCICLK3	9	0b	When set, overrides the CLKRUN# and 33MHz PCICLK3 continues to run.
ClkrunOvrridePCICLK4	10	0b	When set, overrides the CLKRUN# and 33MHz PCICLK4 continues to run.
ClkrunOvrrideLPCCLK	11	0b	When set, overrides the CLKRUN# and LPCCLK continues to run.
ClkrunOvrrideLPCCLK1	12	0b	When set, overrides the CLKRUN# and LPCCLK1 continues to run
ClkrunOvrridePCICLKFB	13	0b	When set, overrides the CLKRUN# and 33MHz PCICLKFB continues to run. PCICLKFB is the feedback clock that is used internally by PCIB.
Reserved	14	0b	
Reserved	15	0b	
Dual Address Cycle Enable and PCIB_CLK_Stop Override			

MSI Mapping Capability – R - 32 bits - [PCI_Reg: 54h]			
Field Name	Bits	Default	Description
MSI Cap ID	7:0	08h	MSI Capability ID
MSI Cap Pointer	15:8	00h	MSI Capabilities Pointer
MSI Cap Enable	16	1b	MSI Capabilities Enable
MSI Fixed	17	1b	MSI Fixed
MSI Reserved	26:18	000h	Reserved
MSI CapType	31:27	15h	MSI Capability Type
MSI Mapping Capability			

Signature Register for Microsoft Rework for Subtractive Decode - R - 32 bits - [PCI_Reg: 58h]			
Field Name	Bits	Default	Description
Signature Register for Microsoft Rework for Subtractive Decode	31:0	00000000h	When Microsoft® Rework for Subtractive Decode is done, this register will contain the signature value
Signature Register for Microsoft Rework for Subtractive Decode			

Prefetch Timeout Limit - 16 bits - [PCI_Reg: 5Ch]			
Field Name	Bits	Default	Description
Prefetch Timeout Limit	15:0	0085h	When deep prefetch is enabled (reg0x64[7]=1), this timer determines when to flush the staled data in the buffer. Each count is 30ns

SPCI IDSEL MaskB - 16 bits - [PCI_Reg: 5Eh]			
Field Name	Bits	Default	Description
PCI IDSEL MaskB	15:0	FFFFh	Each bit represents the masking the specific device on the PCI bus. The purpose of this register is to hide the device from OS 0: The corresponding IDSEL bit is masked 1: The corresponding IDSEL bit is not masked.

Prefetch Size Control - 32 bits - [PCI_Reg: 60h]			
Field Name	Bits	Default	Description
Read Size	2:0	2h	If prefetch function is enabled, this defines the number of initial prefetch cachelines for a PCI READ command
Read Size Adjustment	3	1b	When set, PCIBridge will adjust the prefetch size for READ automatically. If this bit is 0, then the prefetch size is always defined by bits [2:0]
Read Line Size	6:4	4h	If prefetch function is enabled, this defines the number of initial prefetch cachelines for a PCI READLINE command
Read Line Adjustment	7	1b	When set, PCIBridge will adjust the prefetch size for READ_LINE automatically. If this bit is 0, then the prefetch size is always defined by bits [6:4]
Read Multiple Size	10:8	6h	If prefetch function is enabled, this defines the number of initial prefetch cachelines for a PCI READ_MULTIPLE command
Read Multiple Adjustment	11	1b	When set, PCIBridge will adjust the prefetch size for READ_MULTIPLE automatically. If this bit is 0, then the prefetch size is always defined by bits [10:8]
Prefetch Size Lower Limit	14:12	0h	The lower limit of the adjusted prefetch size.
Reserved	15	0b	
Prefetch Size Upper Limit	18:16	7h	The upper limit of the adjusted prefetch size.
Reserved	19	0b	
Prefetch Size Mlt Enable	20	1b	This also controls how PCIBridge adjusts the auto-prefetch size. When set, PCIBridge will only adjust the prefetch size if it knows it does not have enough or has too much data in the prefetch buffer. Recommendation is to always set this bit.
Reserved	31:21	0h	

The fields in this register are effective only when prefetch is enabled (reg0x64[7]=1).

Misc Control Register - 32 bits - [PCI_Reg: 64h]			
Field Name	Bits	Default	Description
Downstream Config Cycle Flush Enable	0	0h	When this bit is 1, any downstream config cycle will flush all the upstream read prefetch buffers.
Downstream Write Cycle Flush Enable	1	1h	When this bit is 1, any downstream non-config write cycle will flush all the upstream read prefetch buffers.
Downstream Read Cycle Flush Enable	2	0h	When this bit is 1, any downstream non-config read cycle will flush all the upstream read prefetch buffers.
Prefetch Buffer Timeout Enable	3	1h	When this bit is 1, upstream read prefetch buffer timeout mechanism is enabled. If data stay in a buffer longer than the time specified in Prefetch Timeout Limit (Reg5Ch), the buffer will be flushed.
AB Masking Prefetch Request Enable	4	1h	The purpose of this bit is to improve the internal bus efficiency and the recommendation is to have it set to 1
AB Masking Non-prefetch Request Enable	5	1h	The purpose of this bit is to improve the internal bus efficiency and the recommendation is to have it set to 1
Downstream Cycle Flush Control	6	0h	0: If a downstream cycle is qualified to flush upstream prefetch read buffer (depending on bit[2:0] in this register), the flush happens when the cycle is sent out onto pci bus with at least one data phase.. 1: If a downstream cycle is qualified to flush upstream prefetch read buffer (depending on bit[2:0] in this register), the flush happens as soon as the cycle arrives at pci bus.

Misc Control Register - 32 bits - [PCI_Reg: 64h]			
Field Name	Bits	Default	Description
Prefetch Enable For Upstream Read Line and Read Multiple	7	1h	0: Prefetch is disabled for upstream memory read line and memory read multiple. 1: Prefetch is enabled for upstream memory read line and memory read multiple. Also refer to reg0x64[21].
PCI5 Enable	8	0h	Setting this bit will enable PCIGNT5#/PCIREQ5# and PCICLK7. Note: These three pins are all using this single configuration bit to enable them into PCI functionality. Care should therefore be taken to ensure that they are used as intended. Since PCICLK7 is not programmed as PCICLK by default, the BIOS needs exercise a certain sequence in order to make the clock valid. For more information consult the <i>AMD SP5100 Register Programming Requirements</i> guide. In ASIC revision A12, this function is moved to PMIO_41h[1]. This bit becomes obsolete.
Arbiter 2 Enable	9	0h	Enables the use of the new PCI bus arbiter to replace the old arbiter.
Hold Current Grant	10	0h	When set, PCIGNT# will not be deasserted until the requesting agent deasserts its PCIREQ#. This only applies to the new PCI bus arbiter
Single Cycle Prefetch Control	11	1h	If a prefetch read cycle comes from spci bus, prefetching may not be necessary if the cycle is single data phase. PCIB can optionally treat the single cycle as non-prefetch and only asks for one dword from AB. 1: Turn on the ability to treat single data phase cycle as non-prefetch cycle. 0: Turn off the ability to treat single data phase cycle as non-prefetch cycle.
Fast Grant Deassert En	12	0b	This control bit applies only to the old (default) PCI arbiter. Normally PCIGNT# is deasserted two clocks after PCIREQ# deasserts. With this bit set, PCIGNT# will deassert 1 clock after PCIREQ# deasserts. Recommendation is to have this bit set.
Reserved	18:13	0h	
Upstream Flush Disable	19	0h	If an spci bus device has left some prefetched data in pcib's prefetch buffer(s), and next time the same device comes back with another request that does not consume the prefetched data, the data is flushed. This is to ensure the prefetched data does not become stale when the same device no longer needs it. 0: Such flush is enabled. 1: Such flush is disabled.
One Prefetch Channel Enable	20	0h	When this bit is set to 1, the four upstream read prefetch channels are cut to one channel.
Prefetch Disable for Upstream Normal Mem Read	21		0: Prefetch is enabled for upstream normal memory read (other than read line or read multiple). However, if reg0x64[7]=0, this prefetch is still disabled. 1: Prefetch is disabled for upstream normal memory read (other than read line or read multiple). Also refer to reg0x64[7].
Reserved	31:22	0h	

3.3 Real Time Clock (RTC)

RTC register space (I/O) is backed up by the RTC battery; therefore these registers are NOT cleared by PCI Reset.

Note: Some RTC functions are controlled by, and associated with, certain PCI configuration registers in the SMBus/ACPI device. For more information refer to [section 2.4: SMBus Module and ACPI Block \(Device 20, Function 0\)](#). The diagram below lists these RTC functions and the associated registers.

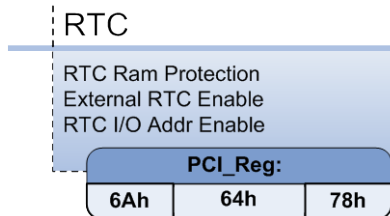

For software compatibility, the RTC registers and RAM are accessed through IO ports 70h/71h and with the banks (Bank 0 and Bank 1) address selected, which are shown in the diagram below. Bank 0 is selected if DV0 = 0 (DV0 is the 5th bit of Register A) while Bank 1 is chosen if DV0 = 1. Although there are two banks defined, the first 64 bytes (00h – 3Fh) are identical in each bank and should return the same value. Note: when Bank 1 is selected, byte offsets 00h – 0Dh Time/Alarm/Control registers and byte offsets 0Eh – 3Fh User RAM are read-only.

There are extended RAM space, x80 ~ xFF, defined later and accessed in a different way. One way to access the extended RAM space from x80 ~ xFF is through the indirect access of Bank 1, offset 50h/53h, which is defined to be the ExtendedRAMAddressPort.

The other way to access the extended RAM is through IO port 72h/73h, which are defined as the address/data ports for the extended RAM space. These two ports do not use the Bank 0/Bank 1 scheme. Memory can be accessed directly using the 8-bit address port. Use of the two IO ports 72h/73h to access the RTC RAM is highly recommended.

Note: Some RTC RAM space can be protected from read/write if corresponding bits are set to 1 in RTCPProtect register (PCI_Reg 6Ah).

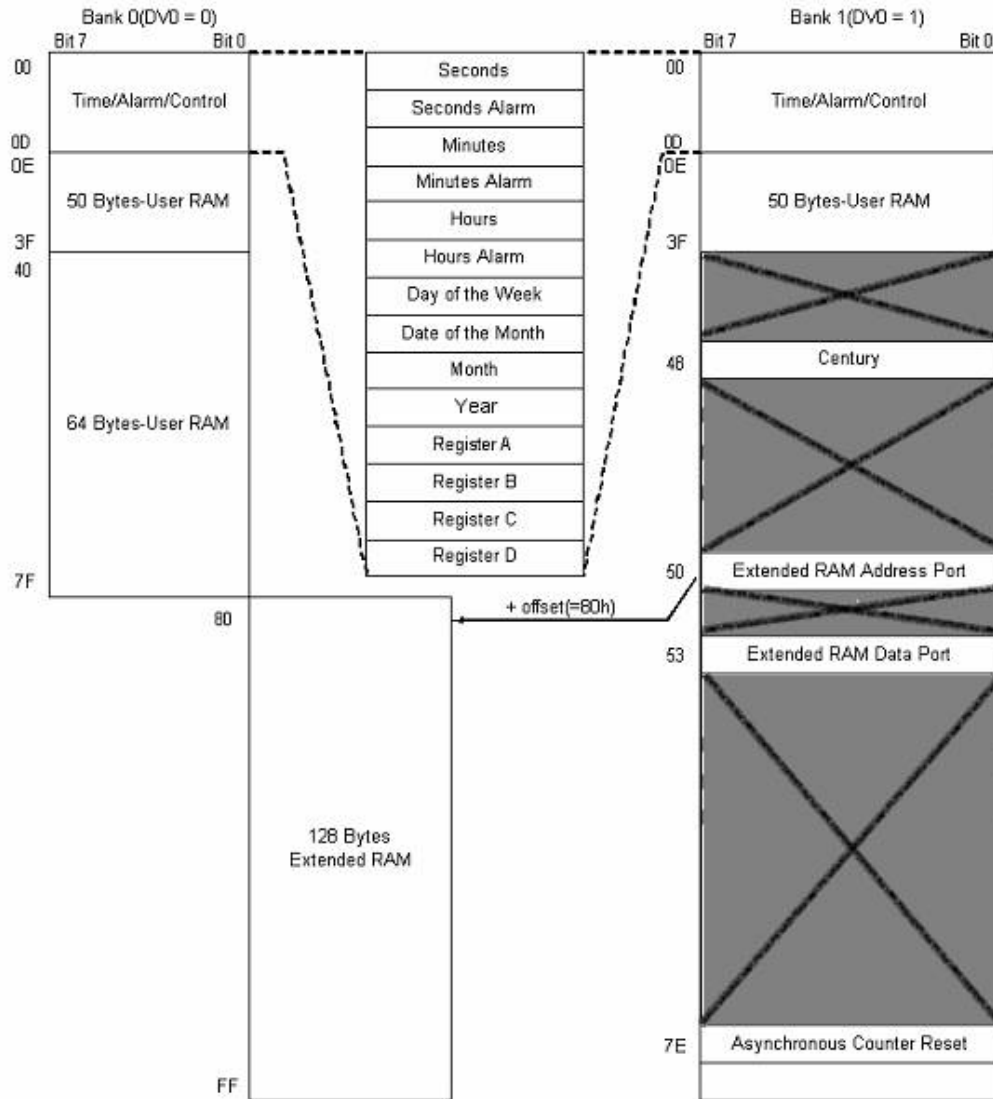

Figure 4: Register Bank Definition and Memory Address Mapping

The analog portion consists of two major parts: one is a 256-byte CMOS RAM and the other a 44-bit ripple counter.

Register Name	Offset Address
Seconds	00h
Seconds Alarm	01h
Minutes	02h
Minutes Alarm	03h
Hours	04h
Hours Alarm	05h
Day of Week	06h
Date of Month	07h
Month	08h
Year	09h
Register A	0Ah
Register B	0Bh
Register C	0Ch
Register D	0Dh

Register Name	Offset Address
AltCentury (when DV0=0)	32h
Century (when DV0=1)	48h
Extended RAM Address Port	50h
Extended RAM Data Port	53h
RTC Time Clear	7Eh
RTC RAM Enable	7Fh

Note: Registers that are implemented in the internal RTC are described below.

Seconds - RW – 8 bits - [RTC_Reg: 00h]			
Field Name	Bits	Default	Description
Seconds	7:0	00h	Binary-Code-Decimal format. Range:00 – 59 This register can be set by software (set bit of Register B = 1) or can be automatically updated by hardware every second. When set by software, hardware updating is disabled.
Seconds register			

Seconds Alarm - RW – 8 bits - [RTC_Reg: 01h]			
Field Name	Bits	Default	Description
Seconds Alarm	7:0	00h	Binary-Code-Decimal format. If set bit = 1, the Seconds Alarm Register will never match with Seconds Register, else If bits [7:6] = [11], the Seconds Alarm Register always matches with Seconds Register.
Seconds Alarm register			

Minutes - RW – 8 bits - [RTC_Reg: 02h]			
Field Name	Bits	Default	Description
Minutes	7:0	00h	Binary-Code-Decimal format. Range:00 – 59 This register can be set by software (set bit of Register B = 1) or can be automatically updated by hardware every minute. When set by software, hardware updating is disabled.
Minutes register			

Minutes Alarm - RW – 8 bits - [RTC_Reg: 03h]			
Field Name	Bits	Default	Description
Minutes Alarm	7:0	00h	Binary-Code-Decimal format. If set bit = 1, the Minutes Alarm Register will never match with Minutes Register, else If bits [7:6] = [11], the Minutes Alarm Register always matches with Minutes Register.
Minutes Alarm register			

Hours - RW – 8 bits - [RTC_Reg: 04h]			
Field Name	Bits	Default	Description
Hours	7:0	00h	Binary-Code-Decimal format. Range:00 – 23 This register can be set by software (set bit of Register B = 1) or can be automatically updated by hardware every hour. When set by software, hardware updating is disabled.
Hours register			

Hours Alarm- RW – 8 bits - [RTC_Reg: 05h]			
Field Name	Bits	Default	Description
Hours Alarm	7:0	00h	Binary-Code-Decimal format. If set bit = 1, the Hours Alarm Register will never match with Hours Register, else If bits [7:6] = [11], the Hours Alarm Register always matches with Hours Register.
Hours Alarm register			

Day of Week - RW – 8 bits - [RTC_Reg: 06h]			
Field Name	Bits	Default	Description
Day of Week	7:0	00h	Binary-Code-Decimal format. Range: 01 – 07 (Sunday = 1). No leap year correction capability. Leap year correction has to be done by software. This register can be set by a software (set bit of Register B = 1) or can be automatically updated by hardware everyday. When set by software, hardware updating is disabled.
Day of Week register			

Date of Month - RW – 8 bits - [RTC_Reg: 07h]			
Field Name	Bits	Default	Description
Date of Month	7:0	00h	Binary-Code-Decimal format. Range: 01 – 28 for February and no leap year capability. Leap year correction has to be done by software. This register can be set by software (set bit of Register B = 1) or can be automatically updated by hardware everyday. When set by software, hardware updating is disabled.
Date of Month register			

Month - RW – 8 bits - [RTC_Reg: 08h]			
Field Name	Bits	Default	Description
Month	7:0	00h	Binary-Code-Decimal format. Range: 01 – 12. No leap year correction capability. Leap year correction has to be done by software. This register can be set by software (set bit of Register B = 1) or can be automatically updated by hardware every month. When set by software, hardware updating is disabled.
Month register			

Year - RW – 8 bits - [RTC_Reg: 09h]			
Field Name	Bits	Default	Description
Year	7:0	00h	Binary-Code-Decimal format. Range: 00 – 99. No leap year correction capability. Leap year correction has to be done by software. This register can be set by software (set bit of Register B = 1) or can be automatically updated by hardware every year. When set by software, hardware updating is disabled.
Year register			

Register A - RW – 8 bits - [RTC_Reg: 0Ah]			
Field Name	Bits	Default	Description
Rate Selection(RS0)	0	0b	These four rate-selection bits select one of the 13 taps on the 15-stage frequency divider or disable the divider output (flat output signal). The tap selected can be used to generate a periodic interrupt. See the following table for the frequency selection.
Rate Selection(RS1)	1	0b	
Rate Selection(RS2)	2	0b	
Rate Selection(RS3)	3	0b	

Register A - RW – 8 bits - [RTC_Reg: 0Ah]			
Field Name	Bits	Default	Description
Bank Selection(DV0)	4	0b	DV0 = 0 selects Bank 0; DV0 = 1 selects Bank 1. The SP5100, it has an alternate way to access the RAM without the use of bank select bit. Port 72/73 can be used as the index to access the full 256 bytes of RAM directly.
Reserved	6:5		
Update In Progress(UIP) See Note .	7	0b	If set bit = 1, UIP is cleared. If UIP = 1, the update transfer will soon occur. If UIP = 0, the update transfer will not occur for at least 244us. [Read-only]
Register A: Control register Note: SP5100 A12 :The UIP high pulse is 270 μS Typical when SS on SRC clock is OFF and 100μ min when SRC SS is ON.			

Rate Selection Bits				Tap Frequency(Interrupt Rate)
RS3	RS2	RS1	RS0	
0	0	0	0	Flat Signal(None)
0	0	0	1	256 Hz (3.90625 ms)
0	0	1	0	128 Hz (7.8125 ms)
0	0	1	1	8.192 kHz (122.070 us)
0	1	0	0	4.096 kHz (244.141 us)
0	1	0	1	2.048 kHz (488.281 us)
0	1	1	0	1.024 kHz (976.5625 us)
0	1	1	1	512 Hz (1.953125 ms)
1	0	0	0	256 Hz (3.90625 ms)
1	0	0	1	128 Hz (7.8125 ms)
1	0	1	0	64 Hz (15.625 ms)
1	0	1	1	32 Hz (31.25 ms)
1	1	0	0	16 Hz (62.5 ms)
1	1	0	1	8 Hz (125 ms)
1	1	1	0	4 Hz (250 ms)
1	1	1	1	2 Hz (500 ms)

Register B - RW – 8 bits - [RTC_Reg: 0Bh]			
Field Name	Bits	Default	Description
Daylight Saving Enable	0	0b	Both this bit and RtcExt_Reg: 00h bit[0] need to be set to 1 to enable RTC daylight saving feature.
HourMode	1	0b	Hour mode 0: 12 hour mode 1: 24 hour mode
Reserved	3:2	00	
Update Ended Interrupt Enable(UIE)	4	0b	UIE enables the Update End Flag (UF) bit in Register C to assert IRQ. If set bit = 1, UIE is cleared.
Alarm Interrupt Enable (AIE)	5	0b	AIE enables the Alarm Flag (AF) bit in Register C to assert IRQ.
Periodic Interrupt Enable (PIE)	6	0b	PIE enables the Periodic Interrupt Flag (PF) bit in Register C to assert IRQ.
Set new time (SET)	7	0b	If set bit = 1, no internal updating for Time Registers is allowed. If set bit = 0, the Time Registers are updated every second.
Register B: Control register			

Register C - R – 8 bits - [RTC_Reg: 0Ch]			
Field Name	Bits	Default	Description
Reserved	3:0	0h	
Update Ended Interrupt Flag(UF)	4	0b	This bit is set to one after each update cycle. Reading Register C clears UF.
Alarm Interrupt Flag (AF)	5	0b	This bit is set to one if second, minute and hour time has matched the second, minute and hour alarm time. Reading Register C clears AF bit.
Periodic Interrupt Flag (PF)	6	0b	This bit is set to one when an edge is detected on the selected tap (through RS3 to RS0) of the frequency divider. Reading Register C clears PF bit.
Interrupt Request Flag (IRQF)	7	0b	Logically, IRQF = (PF*PIE)+(AF*AIE)+(UF*UIE)+(WF*WIE) where WF and WIE are defined in Extended Control Register 4A and 4B. Reading Register C clears IRQF bit. Any time the IRQF bit is set to one, the #IRQ pin is driven low.
Register C: Control register			

DateAlarm - RW – 8 bits - [RTC_Reg: 0Dh]			
Field Name	Bits	Default	Description
DateAlarm	5:0	00h	DateAlarm in BCD format and is considered when it is set to non-zero value. If this value is set to 0, then date is not compared for alarm generation.
Scratchbit	6	0b	
VRT	7	1b	Valid RAM and Time; refer to VRT_T1 and VRT_T2 registers (PMIO 3E/3F)
Date Alarm Register			

AltCentury - RW – 8 bits - [RTC_Reg: 32h]			
Field Name	Bits	Default	Description
AltCentury	7:0	00h	(This register is accessed only when DV0=0 and PM_Reg 7Ch Bit4=1.) Binary-Code-Decimal format. Leap year correction is done through hardware. This register can be set by software (set bit of Register B = 1) or can be automatically updated by hardware every century. When set by software, hardware updating is disabled.
AltCentury Register			

Century - RW – 8 bits - [RTC_Reg: 48h]			
Field Name	Bits	Default	Description
Century	7:0	00h	(This register is accessed only when DV0=1) Binary-Code-Decimal format. Leap year correction is done through hardware. This register can be set by software (set bit of Register B = 1) or can be automatically updated by hardware every century. When set by software, hardware updating is disabled.
Century Register			

Extended RAM Address Port - RW – 8 bits - [RTC_Reg: 50h]			
Field Name	Bits	Default	Description
ExtendedRAMAddr	6:0	00h	Because only 7 address bits are used in port x70, only lower 128 bytes are accessible through port x71. The Extended RAM (upper 128 bytes) are physically located at address 80H to FFH. In order to access these address, an address offset should be programmed into this register and access them through Extended RAMDataPort. (An offset of x80H will automatically add to this 7-bit address).
Reserved	7		
Extended RAM Address Port register: The address port to access Extended RAM.			

Extended RAM Data Port - RW – 8 bits - [RTC_Reg: 53h]			
Field Name	Bits	Default	Description
Extended RAM Data Port	7:0	xxxxxxx	There is no physical register corresponding to this data port but the data port address is used for decoding to generate appropriate internal control signals.
Extended RAM Data Port register.			

RTC Time Clear - RW – 8 bits - [RTC_Reg: 7Eh]			
Field Name	Bits	Default	Description
RtcTimeClear	0	0b	Setting this bit will clear the RTC second and RTC time will stop
Reserved	7:1	0000000b	
RTC Time Clear register.			

RTC RAM Enable - RW – 8 bits - [RTC_Reg: 7Fh]			
Field Name	Bits	Default	Description
RtcRamEnable	0	1b	Setting this bit will enable access to the RTC RAM
Reserved	7:1	0000000b	
RTC RAM Enable register.			

3.4 IOXAPIC Registers

IOXAPIC registers are in the I/O register space. These registers are cleared by the PCIRST# signal; therefore they will be cleared on a warm boot.

Note: Some IOXAPIC functions are controlled by, and associated with, certain PCI configuration registers in the SMBus/ACPI device. For more information refer to [section 2.4: SMBus Module and ACPI Block \(Device 20, Function 0\)](#). The diagram below lists these IOXAPIC functions and the associated registers.

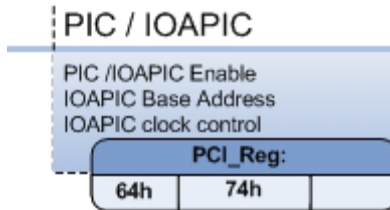

3.4.1 Direct Access Registers

Note: The XAPIC_BASE_REGISTER has a power-on default value of FEC0_0000H.

IO Register Select Register RW [XAPIC_BASE_REGISTER + 00H]			
Field Name	Bits	Default	Description
Indirect Address Offset	7:0	00h	Indirect Address Offset to IO Window Register
Reserved	31:8		
Used to determine which register is manipulated during an IO Window Register read/write operation.			

IO Window Register RW [XAPIC_BASE_REGISTER + 10H]			
Field Name	Bits	Default	Description
Mapped by the value in the IO Register Select Register, to the designated indirect access register. Technically a R/W register; however, the read/write capability is determined by the indirect access register referenced by the IO Register Select Register.			

IRQ Pin Assertion Register RW [XAPIC_BASE_REGISTER + 20H]			
Field Name	Bits	Default	Description
Input IRQ	7:0	00h	IRQ number for the requested interrupt
<reserved>	31:8	0000000h	
Write to this register will trigger an interrupt associated with the redirection table entry referenced by the IRQ number. Currently the redirection table has 24 entries. Write with IRQ number greater than 17H has no effect.			

EOI Register W [XAPIC_BASE_REGISTER + 40H]			
Field Name	Bits	Default	Description
Vector	7:0	00h	Interrupt vector
<reserved>	31:8	0000000h	
Write to this register will clear the remote IRR bit in the redirection table entry found matching the interrupt vector. This provides an alternate mechanism other than PCI special cycle for EOI to reach IOXAPIC.			

3.4.2 Indirect Access Registers

Software needs to first select the register to access using the IO Register Select Register, and then read or write using the IO Window Register.

IOAPIC ID Register [Indirect Address Offset = 00H] RW			
Field Name	Bits	Default	Description
Reserved	23:0	000000h	
ID	27:24	0h	IOAPIC device ID for APIC serial bus delivery mode
Reserved	31:28	0h	
Not used in XAPIC PCI bus delivery mode.			

IOXAPIC Version Register [Indirect Address Offset = 01H] R			
Field Name	Bits	Default	Description
Version	7:0	21h	PCI 2.2 compliant
Reserved	14:8	00h	
PRQ	15	1b	IRQ pin assertion supported
Max Redirection Entries	23:16	17h	24 entries [23:0]
Reserved	31:24	00h	

IOAPIC Arbitration Register [Indirect Address Offset = 02H] R			
Field Name	Bits	Default	Description
Reserved	23:0	000000h	
Arbitration ID	27:24	0h	Arbitration ID for APIC serial bus delivery mode
Reserved	31:28	0h	
Not used in XAPIC PCI bus delivery mode.			

Redirection Table Entry [0–23] [Indirect Address Offset = 11/10H–3F/3EH] RW			
Field Name	Bits	Default	Description
Vector	7:0	00h	Interrupt vector associated with this interrupt input
Delivery Mode	10:8	0h	000: Fixed 001: Lowest Priority 010: SMI/PMI 011: Reserved 100: NMI 101: INIT 110: Reserved 111: ExtINT
Destination Mode	11	0b	0: Physical 1: Logical
Delivery Status	12	0b	Read Only 0: Idle 1: Send Pending
Interrupt Pin Polarity	13	0b	0: High 1: Low
Remote IRR	14	0b	Read Only. Used for level triggered interrupts only. Set when interrupt message delivered. Cleared by EOI special cycle transaction or write to EOI register
Trigger Mode	15	0b	0: Edge 1: Level
Mask	16	1b	Masks the interrupt injection at the input of this device. Write 0 to unmask
Reserved	31:17	0000h	
Reserved	55:32	000000h	

Redirection Table Entry [0–23] [Indirect Address Offset = 11/10H–3F/3EH] RW			
Field Name	Bits	Default	Description
Destination ID	63:56	0	Bits [19:12] of the address field of the interrupt message

Appendix A: Revision History

Date	Rev.	Comment
August, 2012	3.03	<ul style="list-style-type: none">▪ 2.4.3.2: Power Management (PM) Registers:<ul style="list-style-type: none">▪ Updated WatchDogTimerControl [PM_Reg:69h]▪ 2.3.4 USB1/ USB2 EHCI PCI Configuration Registers:<ul style="list-style-type: none">▪ Updated EHCI Misc Control [PCI_Reg: 50h]
January, 2011	3.02	<ul style="list-style-type: none">▪ Update to register EHCI Misc Control [PCI_Reg: 50h] -- added bit[26] description.
November, 2010	3.00	<ul style="list-style-type: none">▪ Public release based on internal version rev 2.07.